



US007924156B2

(12) **United States Patent**  
**Colby**

(10) **Patent No.:** **US 7,924,156 B2**  
(45) **Date of Patent:** **Apr. 12, 2011**

(54) **ELECTRONICALLY SWITCHABLE RFID TAGS**

(76) Inventor: **Steven M. Colby**, Mountain View, CA (US)

(\* ) Notice: Subject to any disclaimer, the term of this patent is extended or adjusted under 35 U.S.C. 154(b) by 1126 days.

(21) Appl. No.: **11/458,620**

(22) Filed: **Jul. 19, 2006**

(65) **Prior Publication Data**

US 2007/0109101 A1 May 17, 2007

**Related U.S. Application Data**

(63) Continuation-in-part of application No. 11/382,050, filed on May 7, 2006, and a continuation-in-part of application No. 11/382,052, filed on May 7, 2006, and a continuation-in-part of application No. 11/382,053, filed on May 7, 2006, and a continuation-in-part of application No. 11/382,054, filed on May 8, 2006, and a continuation-in-part of application No. 11/382,265, filed on May 8, 2006, and a continuation-in-part of application No. 11/382,264, filed on May 8, 2006, and a continuation-in-part of application No. 11/420,721, filed on May 26, 2006.

(60) Provisional application No. 60/678,428, filed on May 6, 2005, provisional application No. 60/685,331, filed on May 27, 2005, provisional application No. 60/700,884, filed on Jul. 19, 2005, provisional application No. 60/712,308, filed on Aug. 30, 2005, provisional application No. 60/715,641, filed on Sep. 10, 2005, provisional application No. 60/752,933, filed on Dec. 21, 2005, provisional application No. 60/758,751, filed on Jan. 13, 2006, provisional application No. 60/782,068, filed on Mar. 13, 2006, provisional application No. 60/744,154, filed on Apr. 3, 2006, provisional application No. 60/746,636, filed on May 6, 2006.

(51) **Int. Cl.**  
**G06F 19/00** (2011.01)  
**H04L 9/32** (2006.01)  
**H04Q 5/22** (2006.01)  
**G08B 13/14** (2006.01)  
**G06K 5/00** (2006.01)

(52) **U.S. Cl.** ..... **340/572.1**; 340/10.1; 340/825.72; 340/5.4; 340/5.41; 340/5.6; 340/5.62; 235/380; 235/382; 235/382.5

(58) **Field of Classification Search** ..... None  
See application file for complete search history.

(56) **References Cited**

**U.S. PATENT DOCUMENTS**

5,640,151	A *	6/1997	Reis et al.	340/10.2
5,686,902	A *	11/1997	Reis et al.	340/10.2
6,282,407	B1 *	8/2001	Vega et al.	455/41.1
6,320,169	B1 *	11/2001	Clothier	219/626
6,593,845	B1 *	7/2003	Friedman et al.	340/10.33
7,246,754	B2 *	7/2007	Siuta et al.	235/492
7,290,709	B2 *	11/2007	Tsai et al.	235/449
2002/0047777	A1 *	4/2002	Casden	340/10.32
2003/0095034	A1 *	5/2003	Clothier	340/10.1
2004/0145453	A1 *	7/2004	Tuttle	340/10.1
2004/0233040	A1 *	11/2004	Lane et al.	340/5.86
2004/0263319	A1 *	12/2004	Huomo	340/10.2
2005/0174239	A1 *	8/2005	Shanks et al.	340/572.1
2005/0253683	A1 *	11/2005	Lowe	340/5.53

(Continued)

*Primary Examiner* — Julie Lieu

(57) **ABSTRACT**

Various switchable RFID devices are disclosed. These switchable RFID devices may include one or more RFID tags and one or more switches. Some of these one or more switches are optionally wireless. In various embodiments, the switchable RFID devices include identity devices, financial devices, remote controls, and the like. In some embodiments, switches are configured to enter data into a switchable RFID device, for example to select a financial account.

**60 Claims, 20 Drawing Sheets**

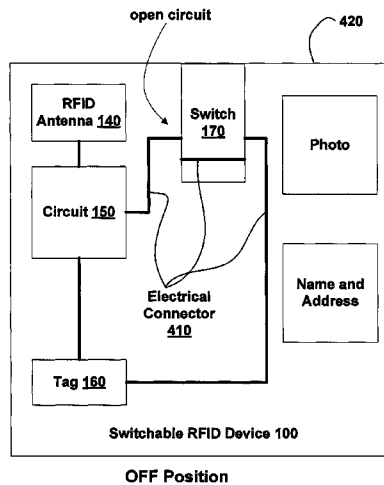

# US 7,924,156 B2

Page 2

---

## U.S. PATENT DOCUMENTS

2005/0263591	A1*	12/2005	Smith .....	235/385	2007/0057792	A1*	3/2007	Alden .....	340/572.1
2006/0186989	A1*	8/2006	Chon et al. ....	340/5.61	2007/0075140	A1*	4/2007	Guez et al. ....	235/435
2007/0024423	A1*	2/2007	Nikitin et al. ....	340/10.1	2007/0090927	A1*	4/2007	Potyrailo et al. ....	340/10.41
2007/0057790	A1*	3/2007	Alden et al. ....	340/572.1	2008/0238679	A1*	10/2008	Rofougaran et al. ....	340/572.2

\* cited by examiner

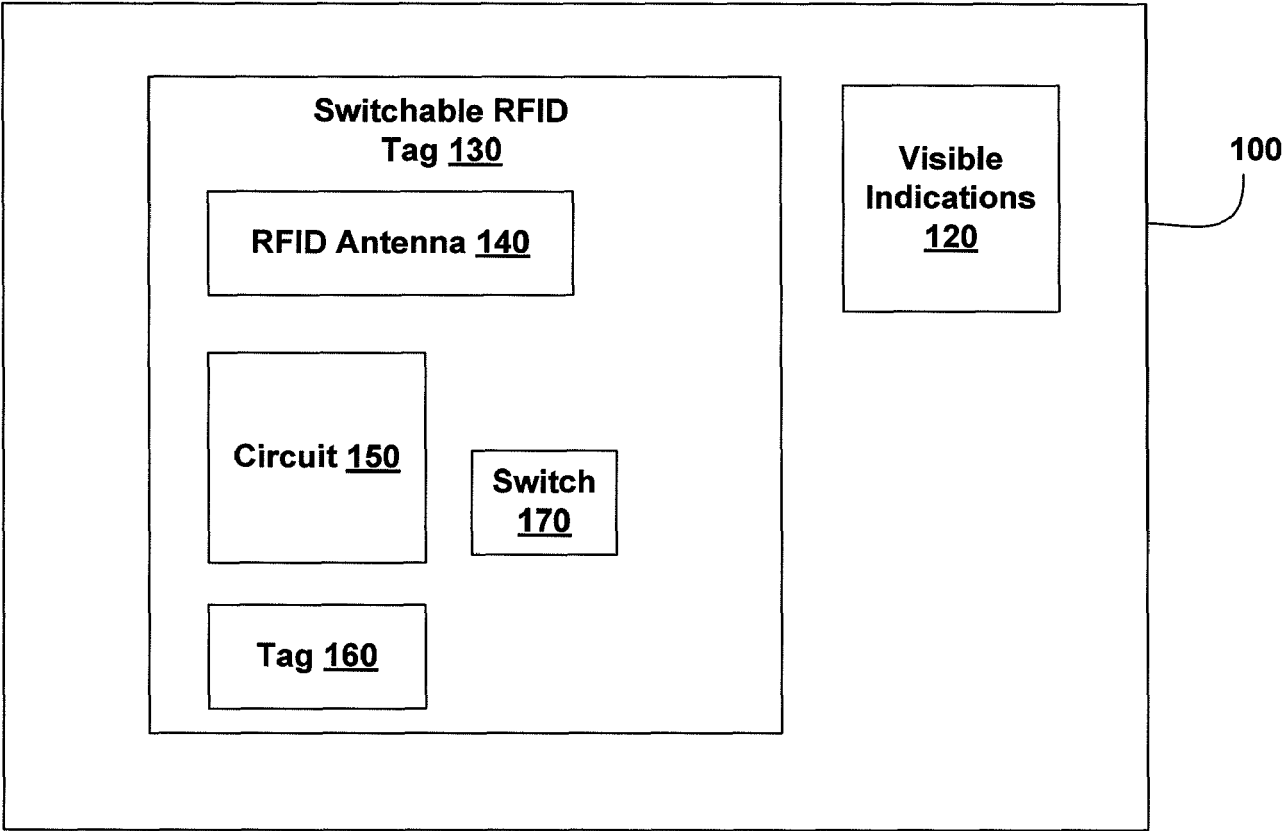

FIG. 1

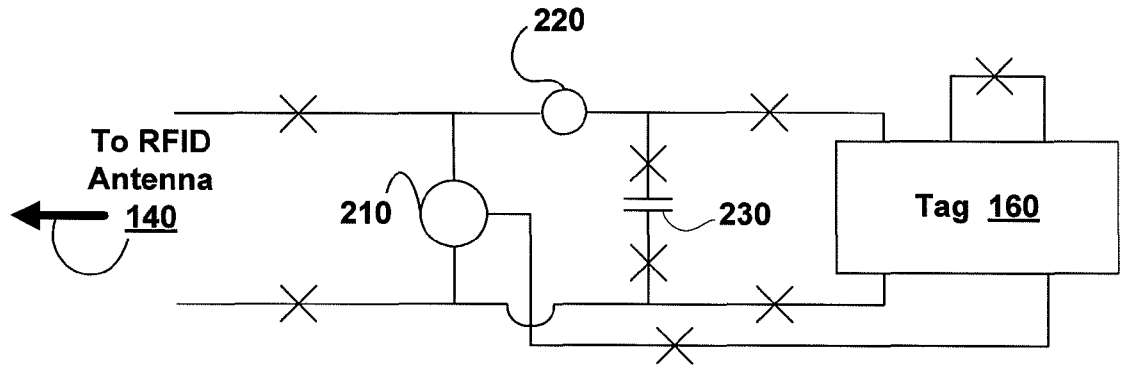

FIG. 2

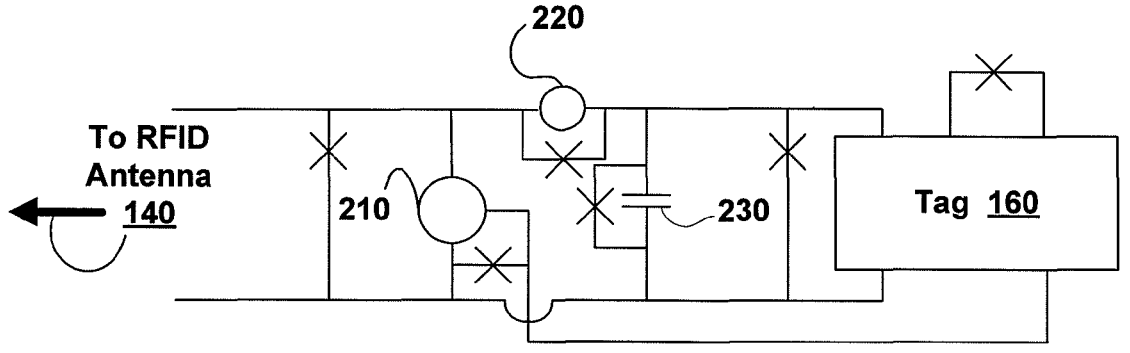
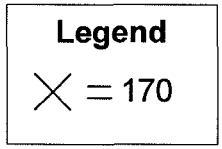
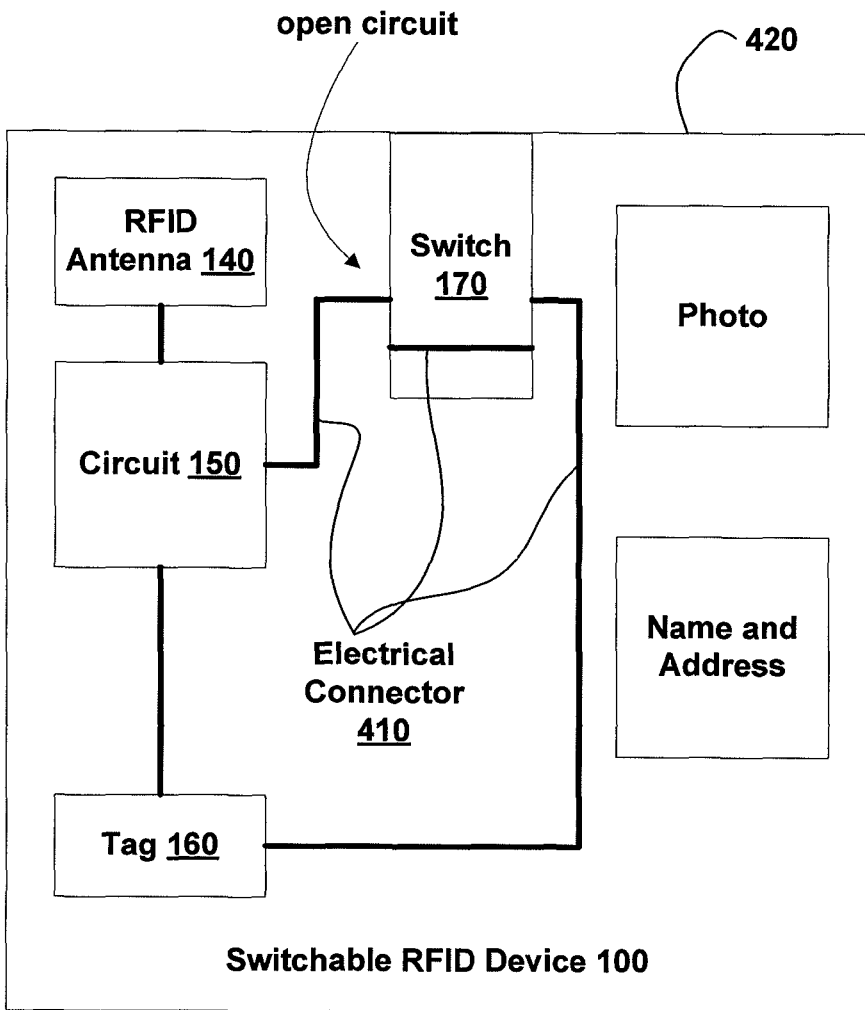
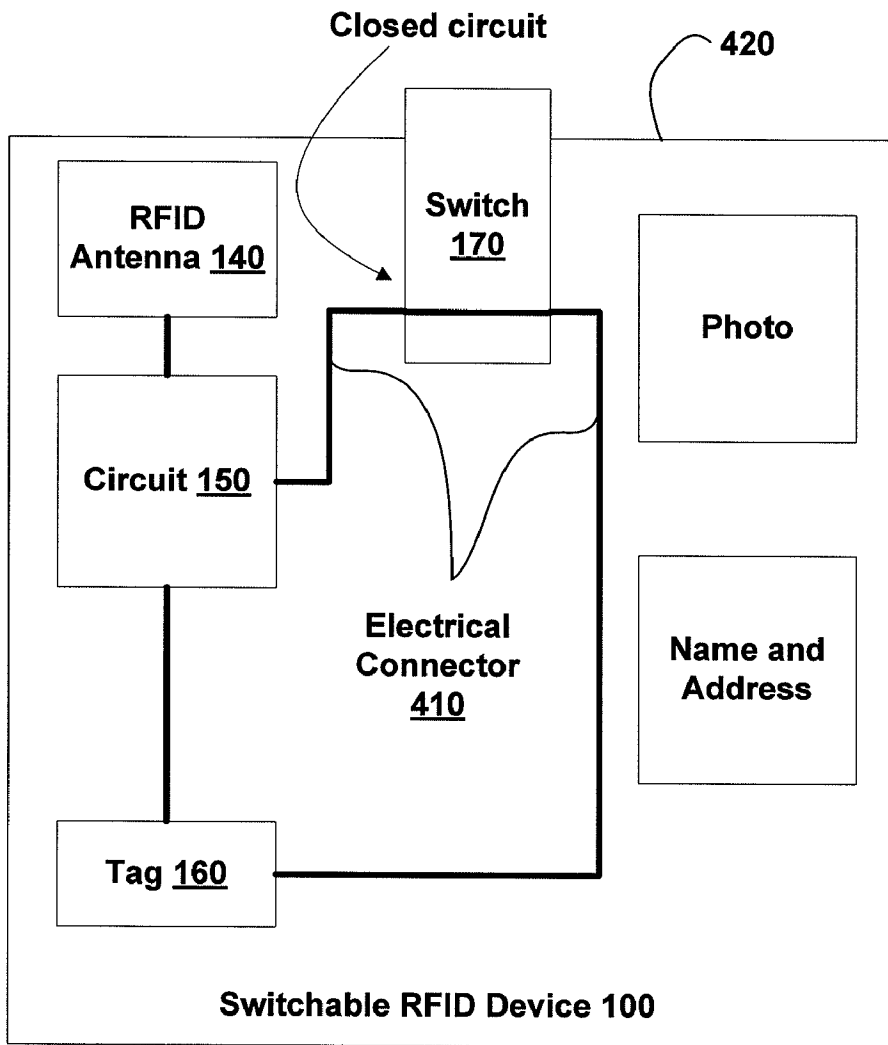

FIG. 3



OFF Position FIG. 4A



**FIG. 4B ON Position**

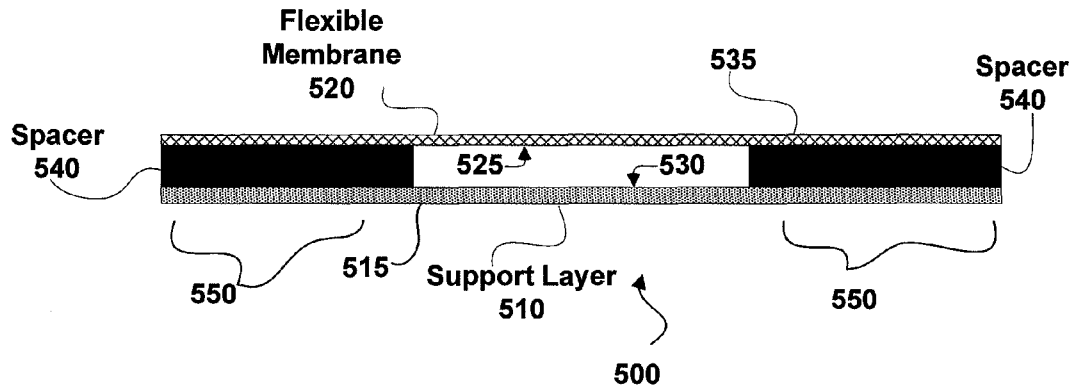

FIG. 5A  
Membrane Switch (OFF)

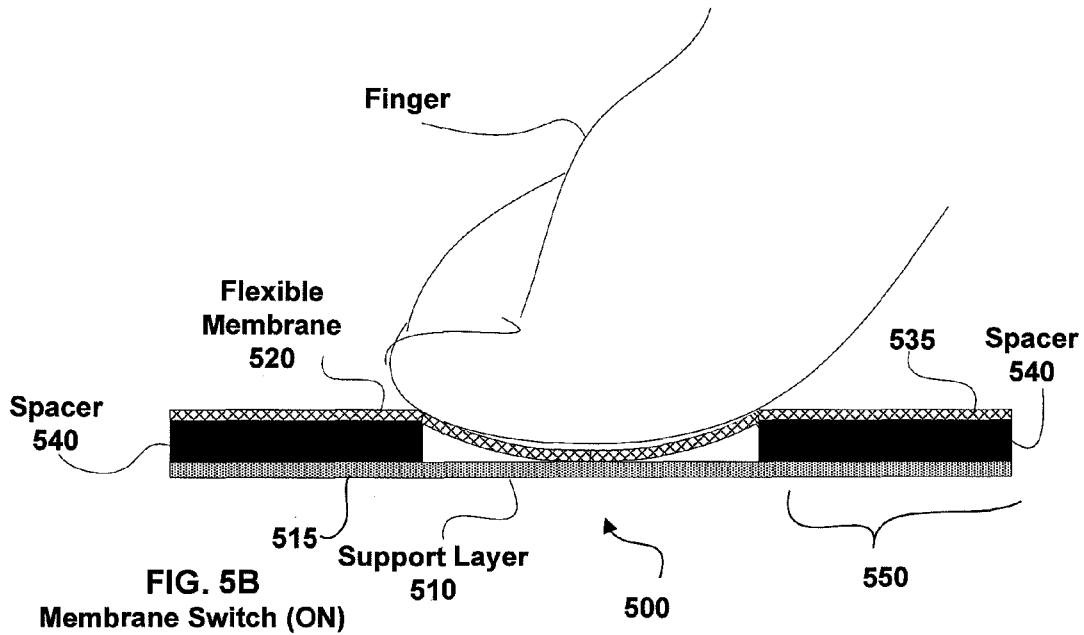
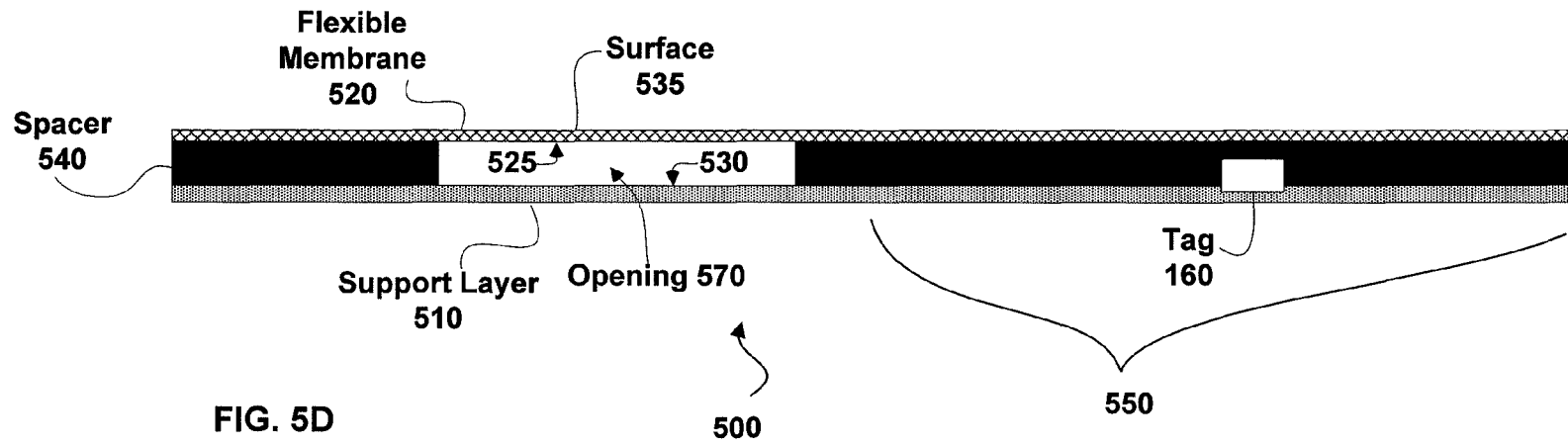
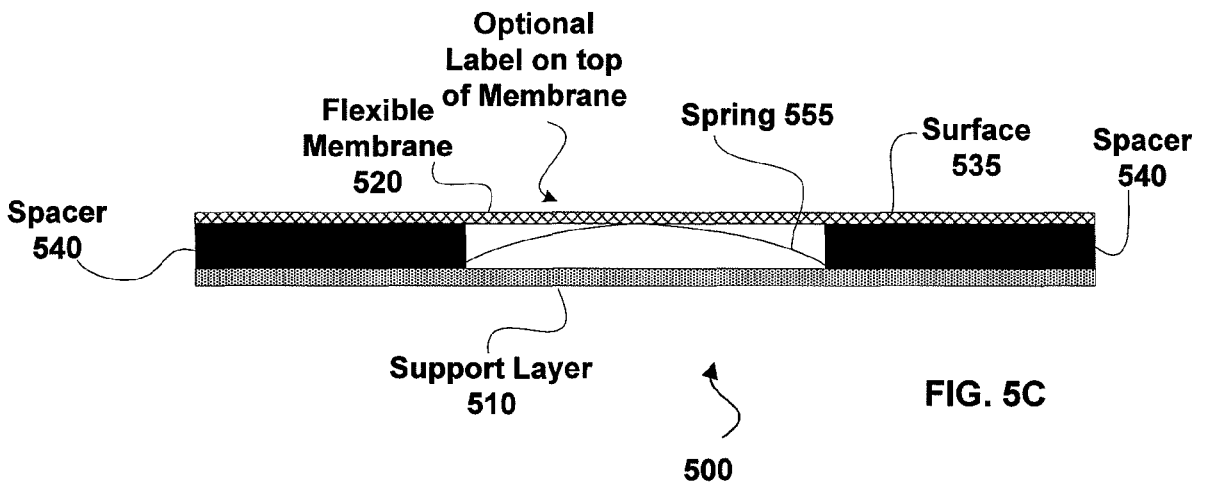

FIG. 5B  
Membrane Switch (ON)





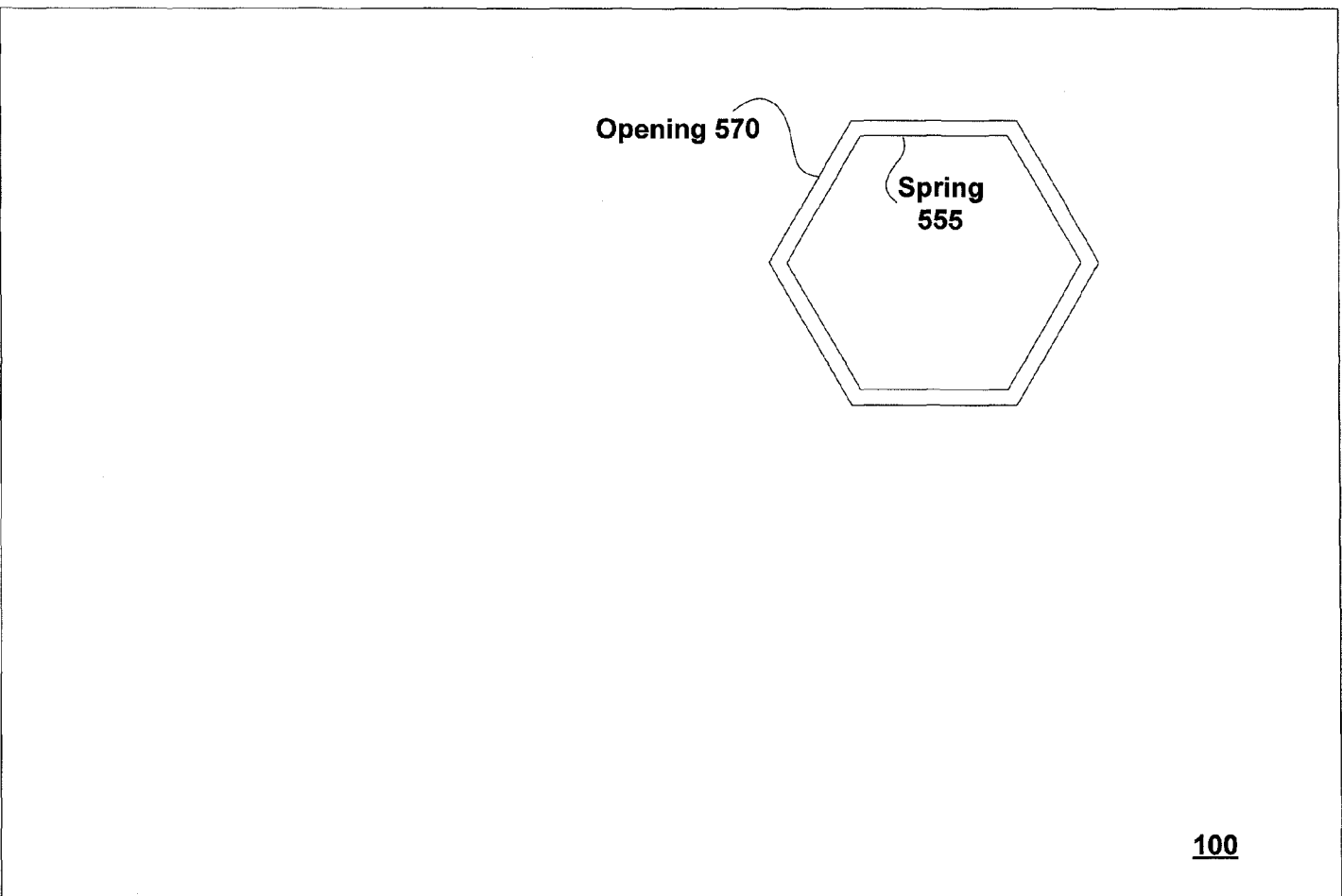

FIG. 6  
(Top View)

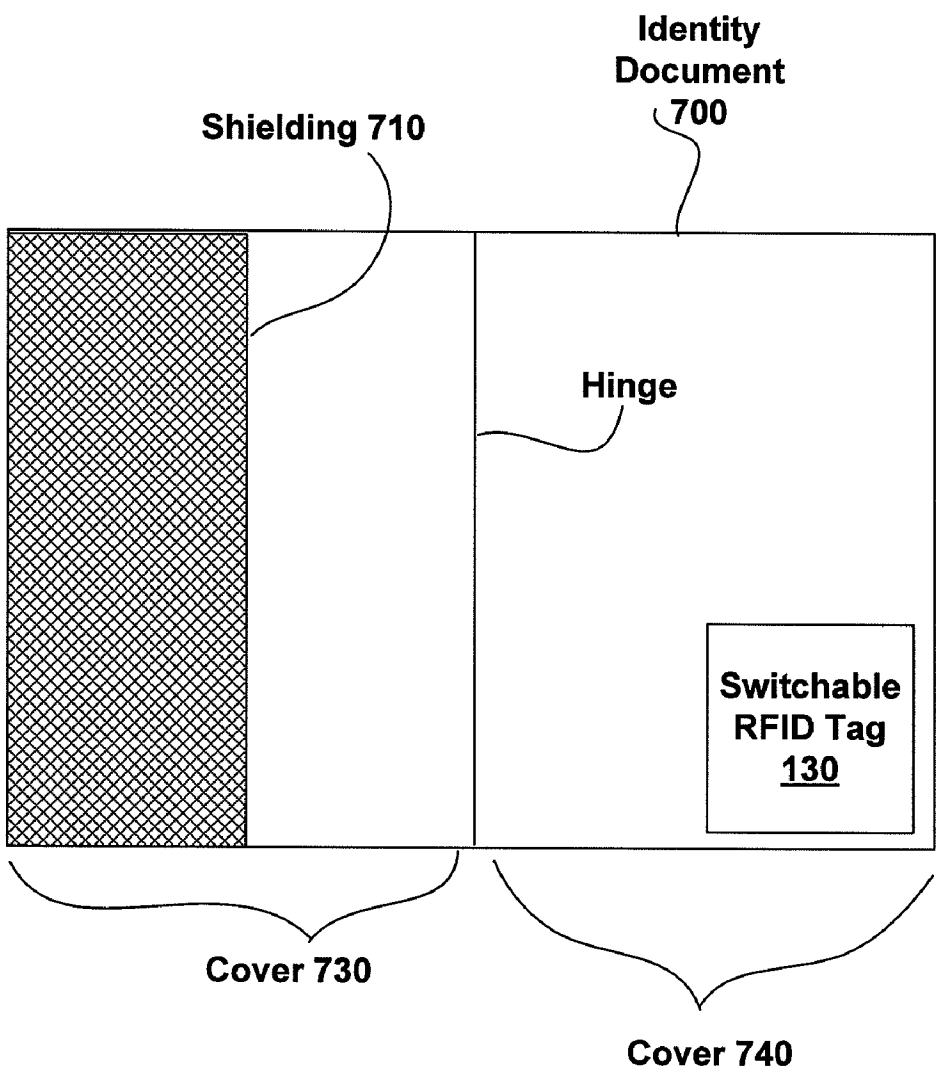

FIG. 7

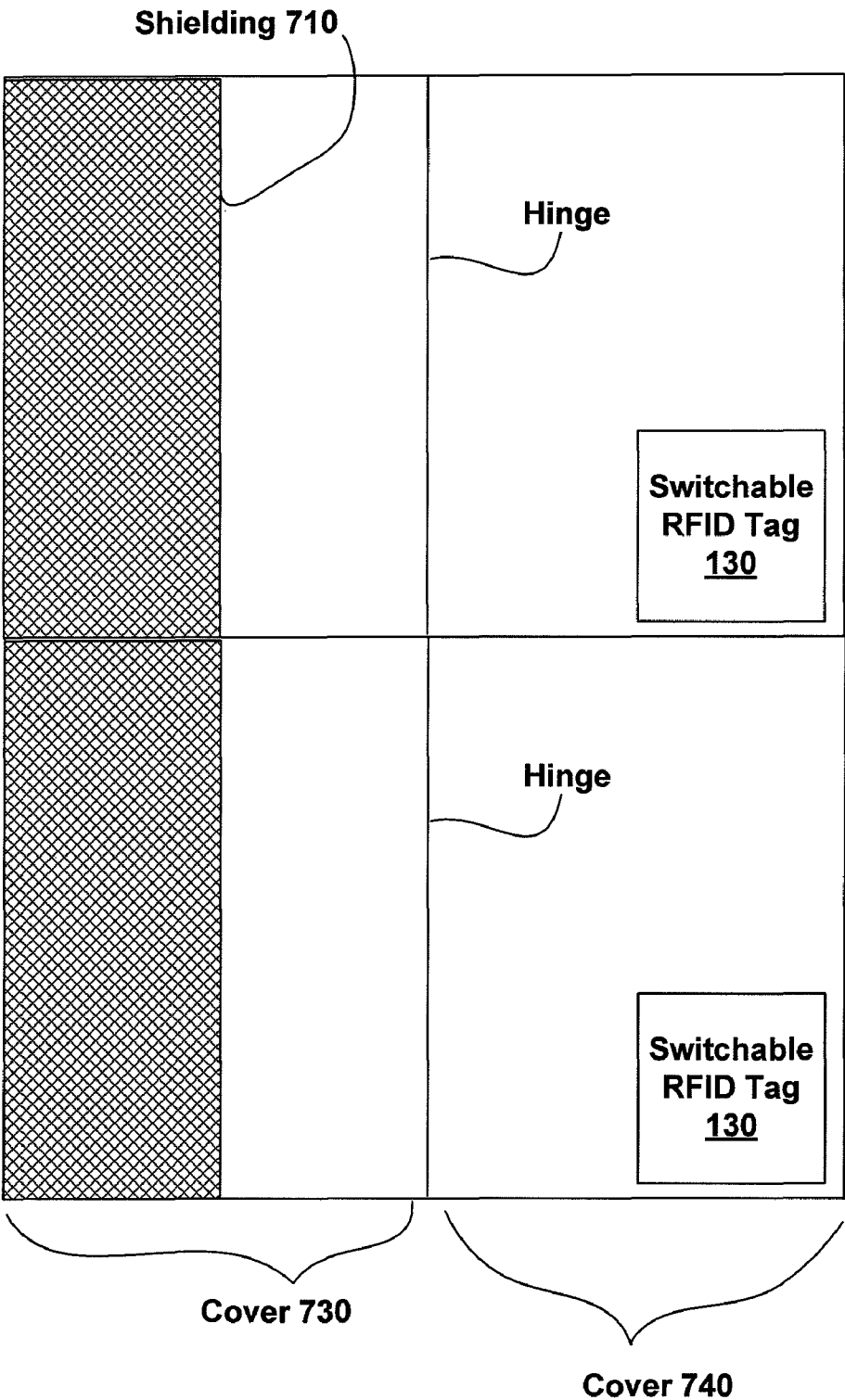

FIG. 8

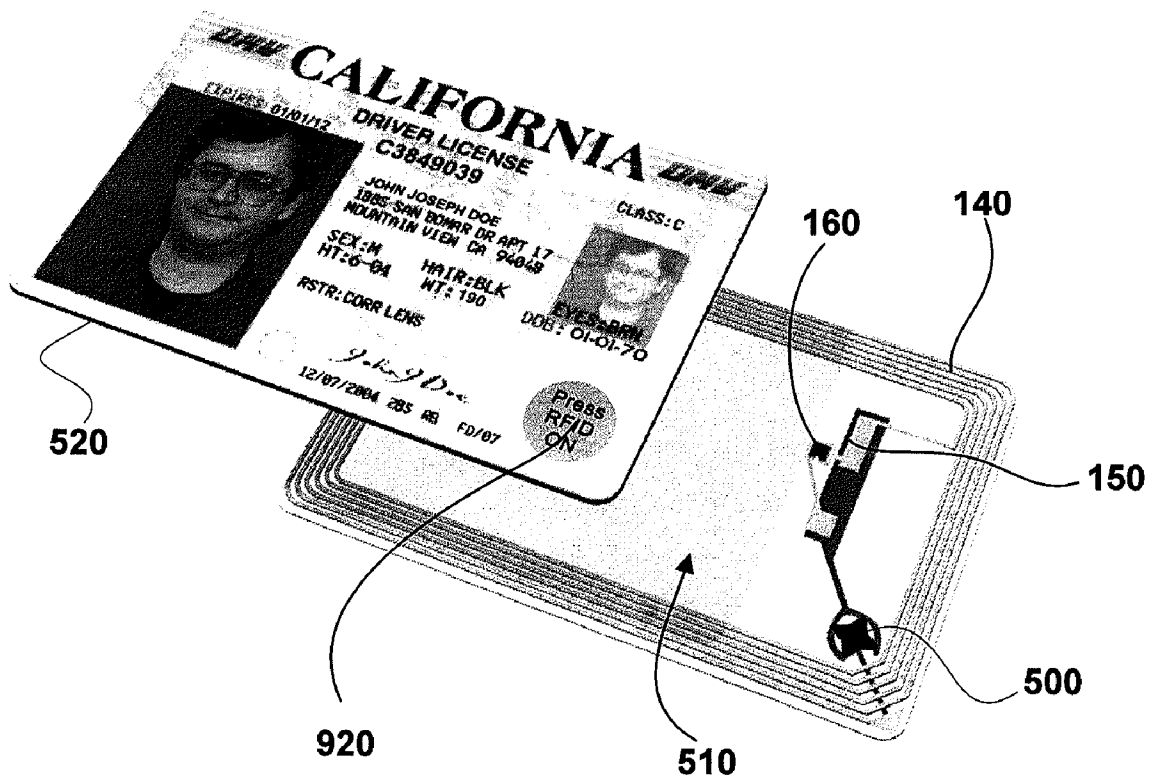

FIG. 9

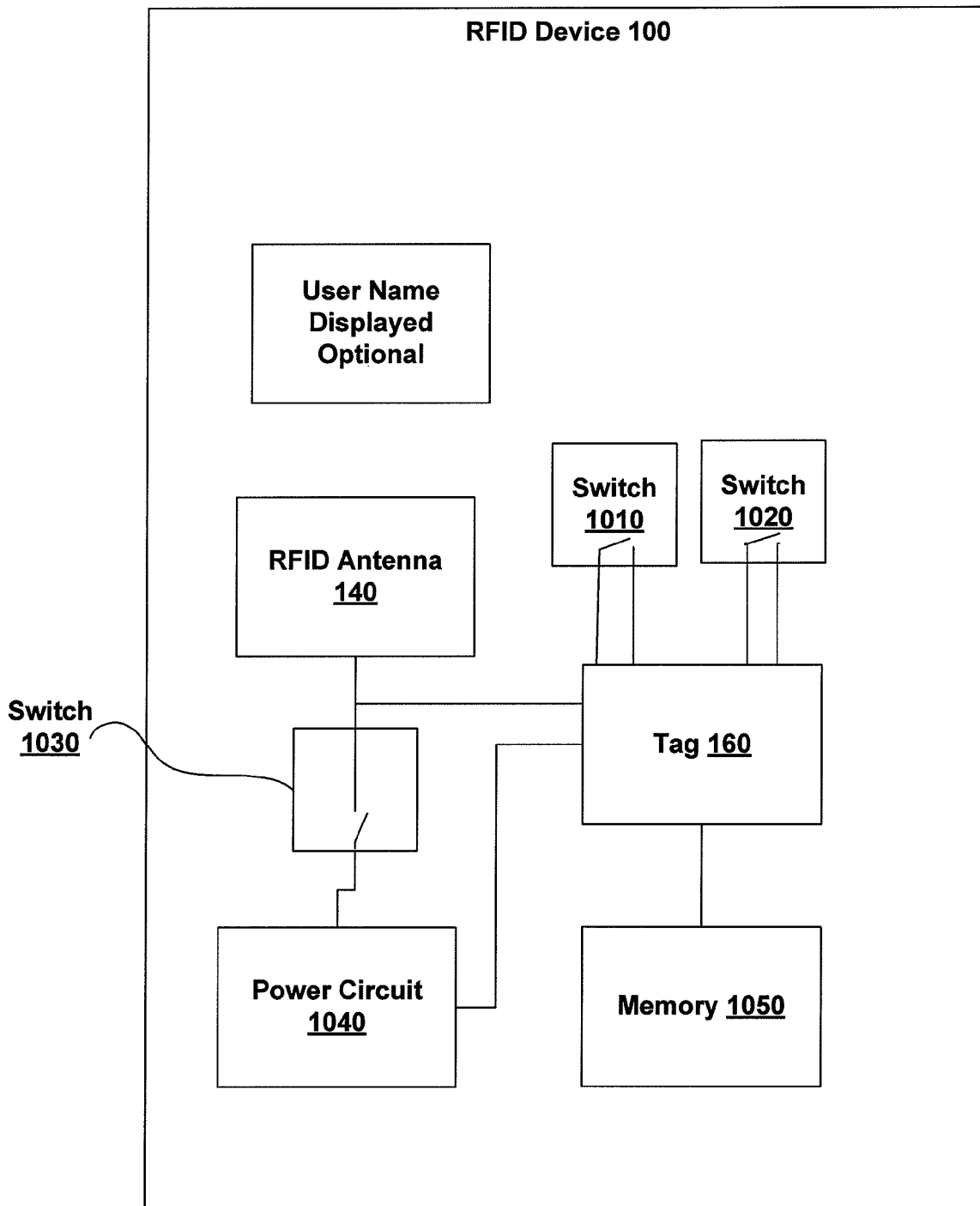

FIG. 10

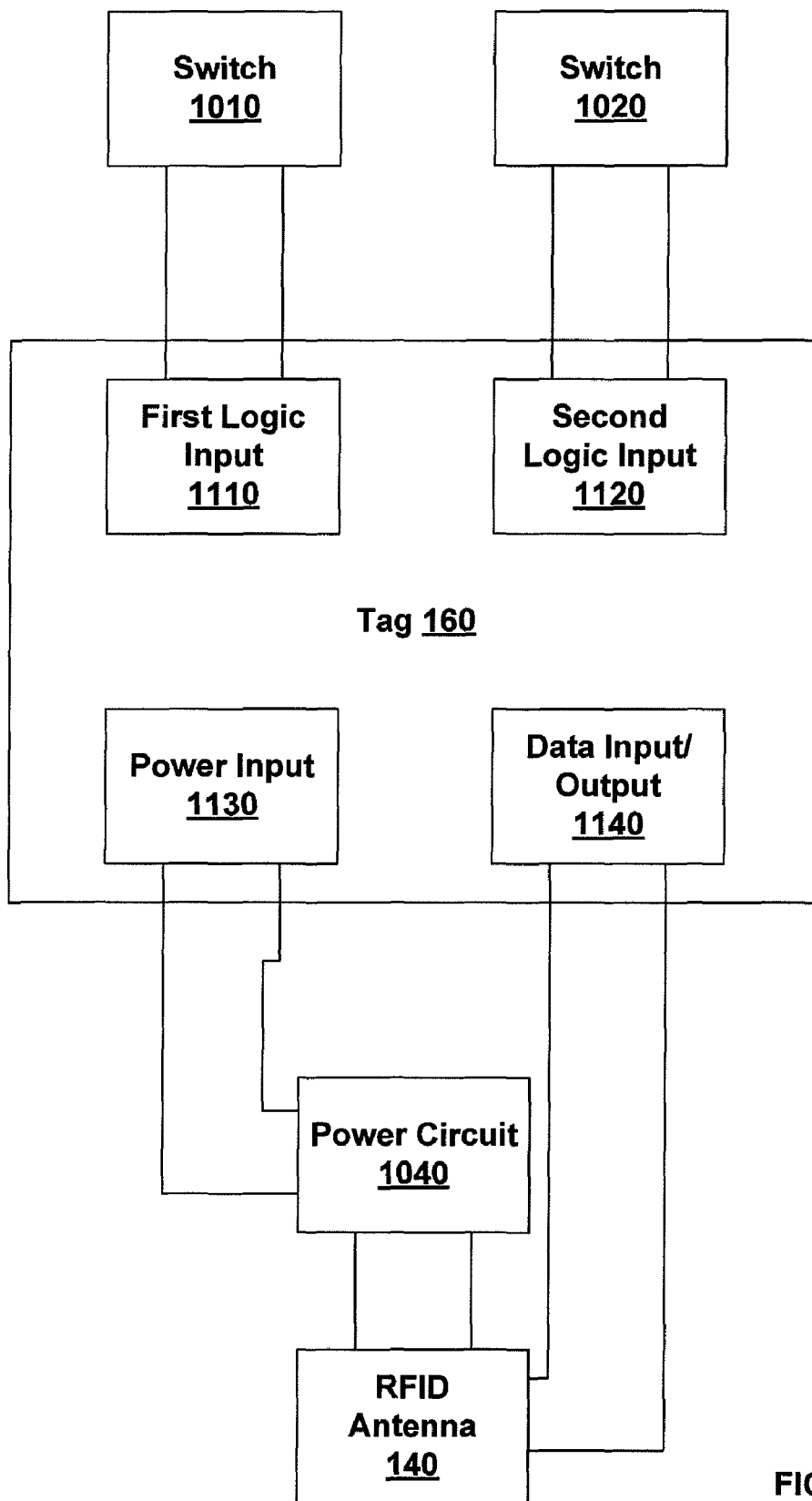

FIG. 11

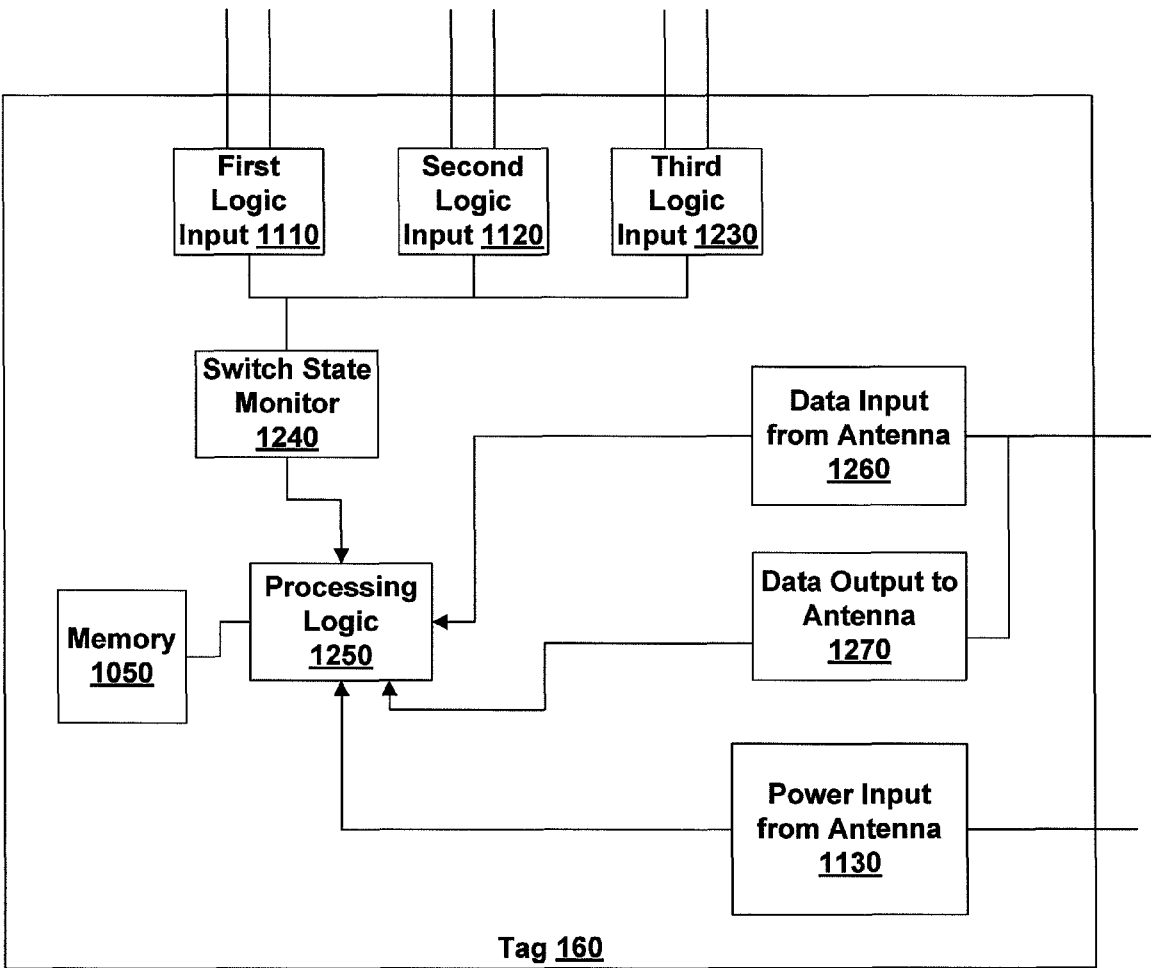

FIG. 12

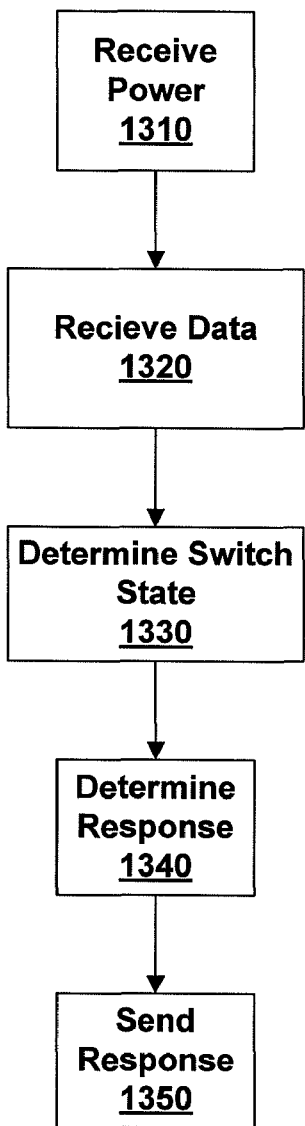

FIG. 13



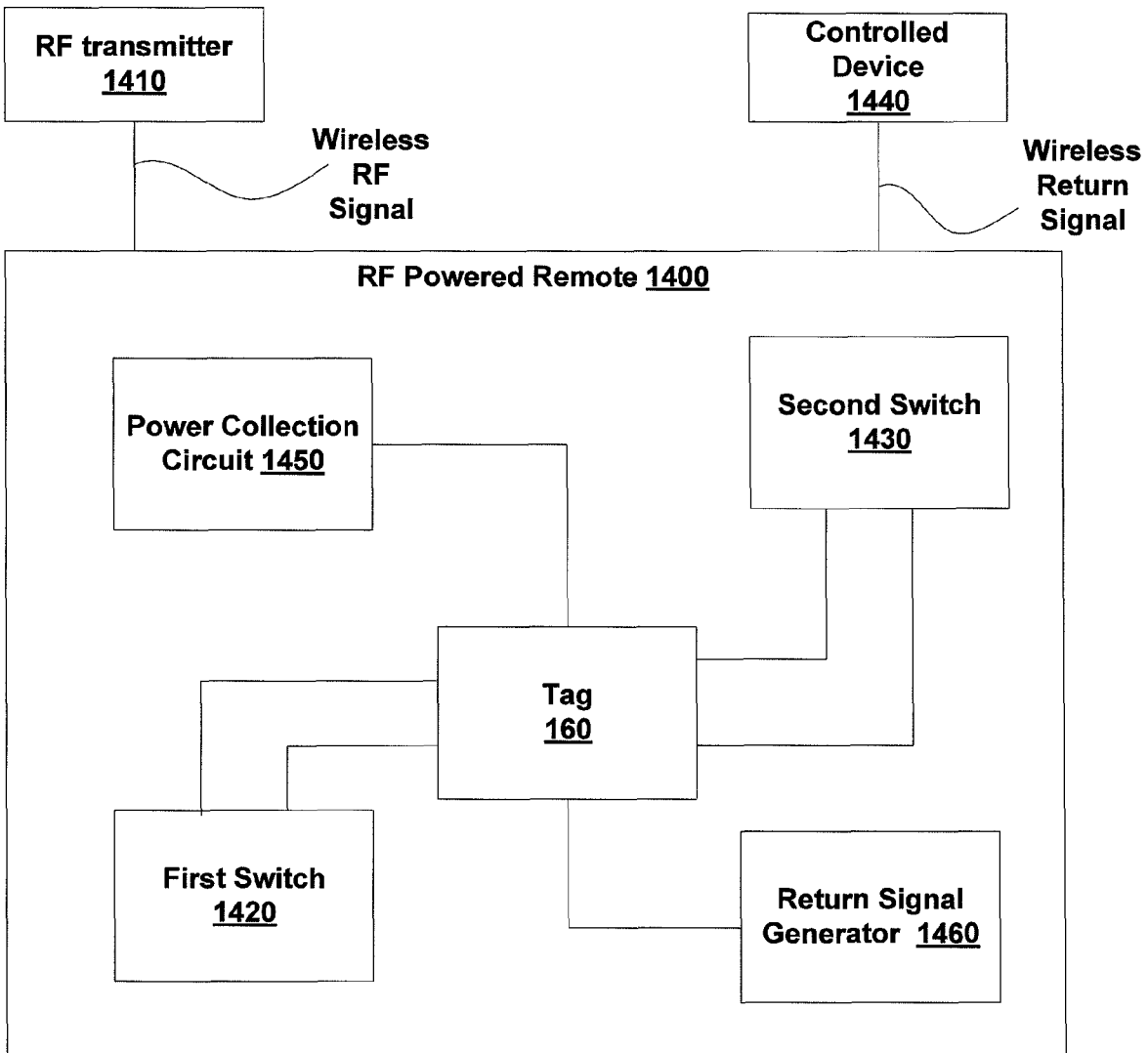

FIG. 14

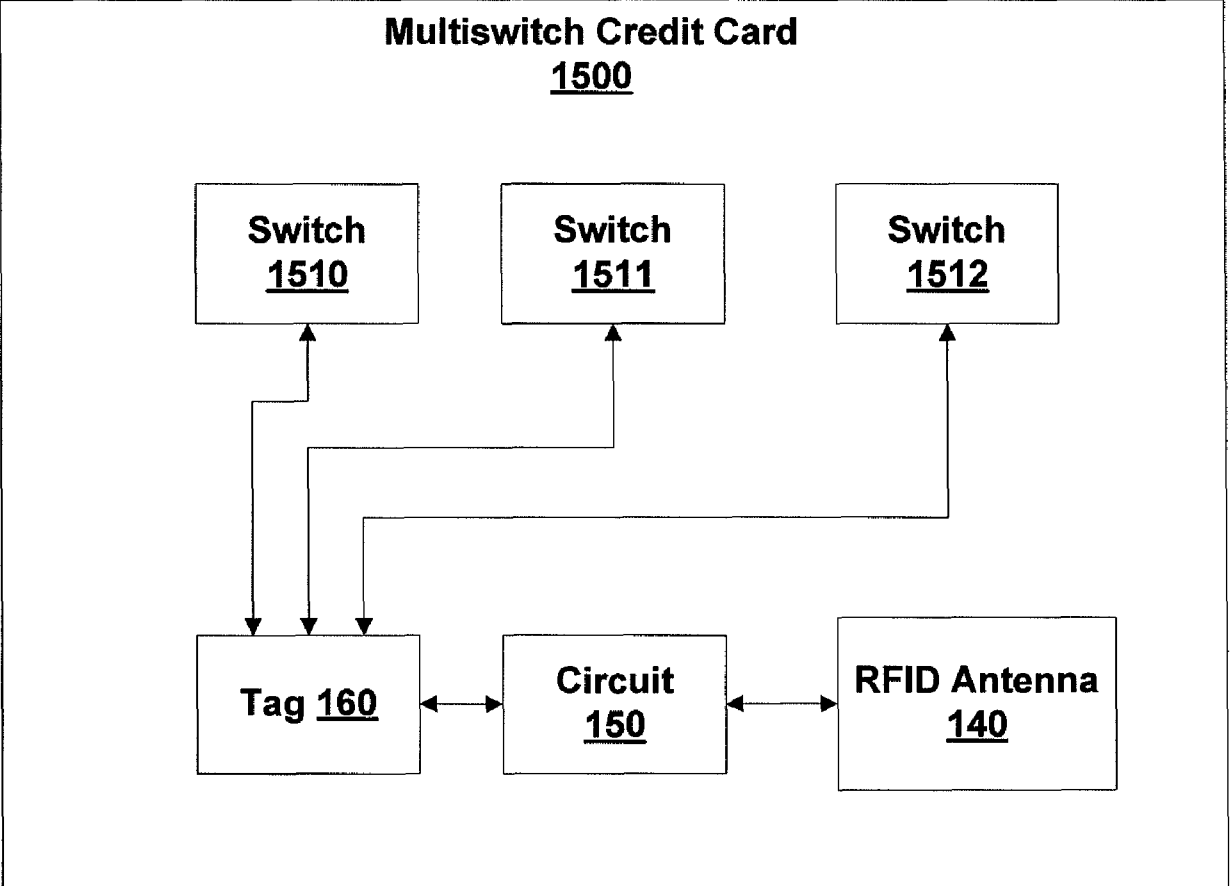

FIG. 15

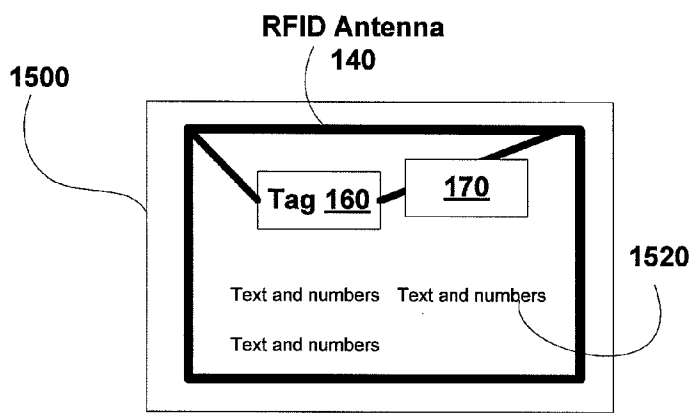

FIG. 16A

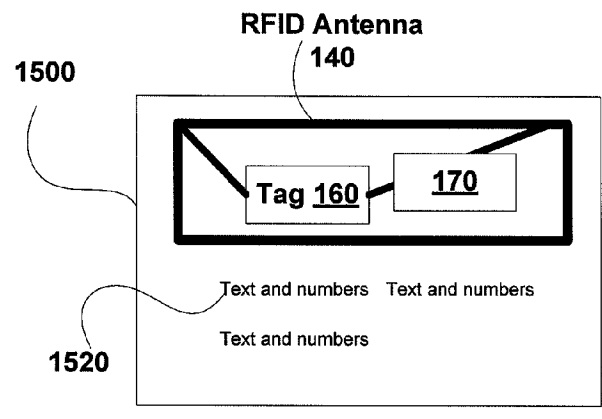

FIG. 16B

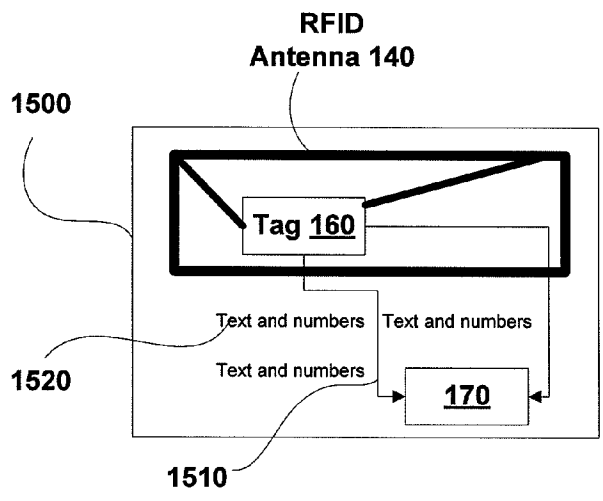

FIG. 16C

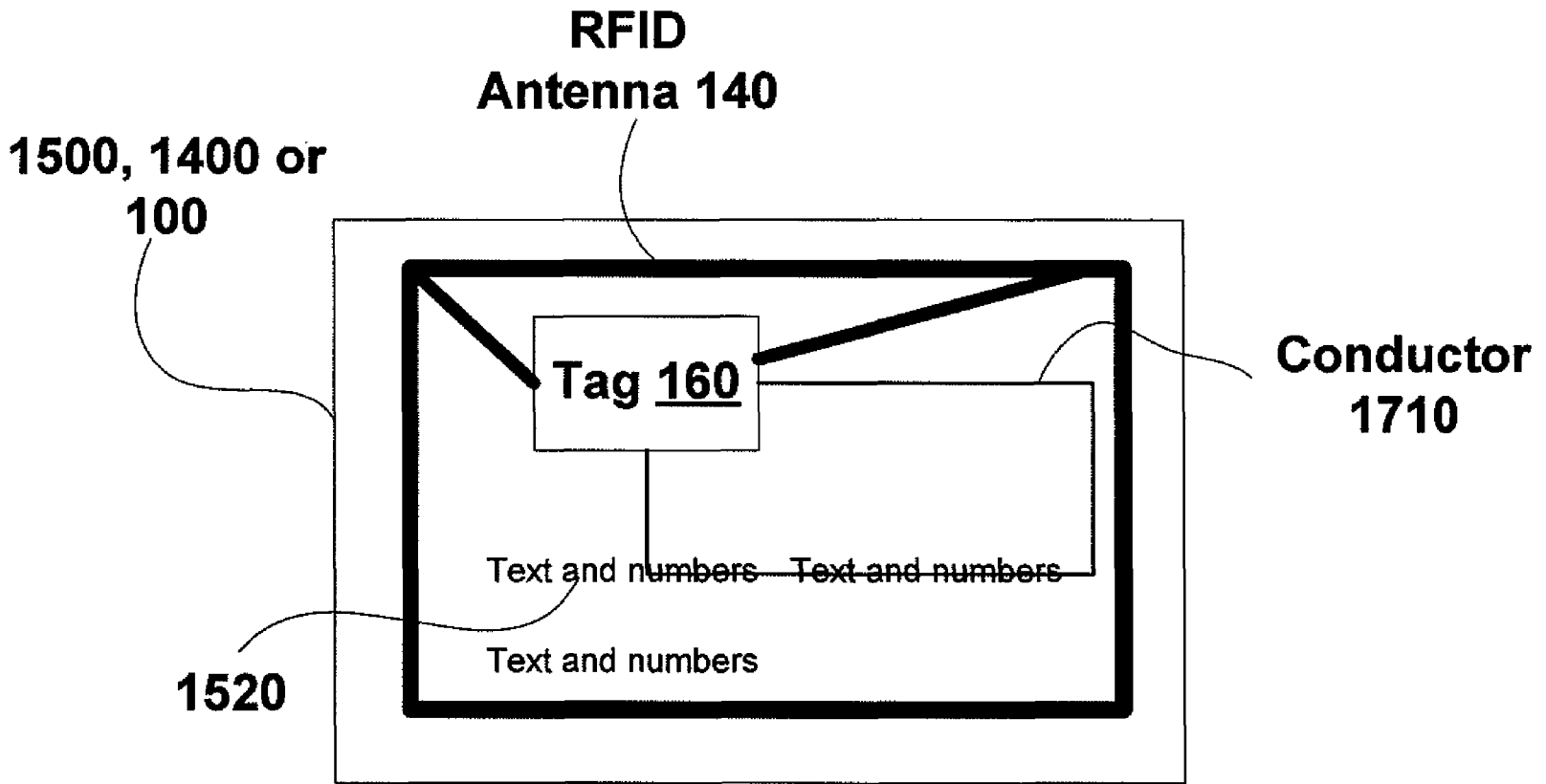

FIG. 17

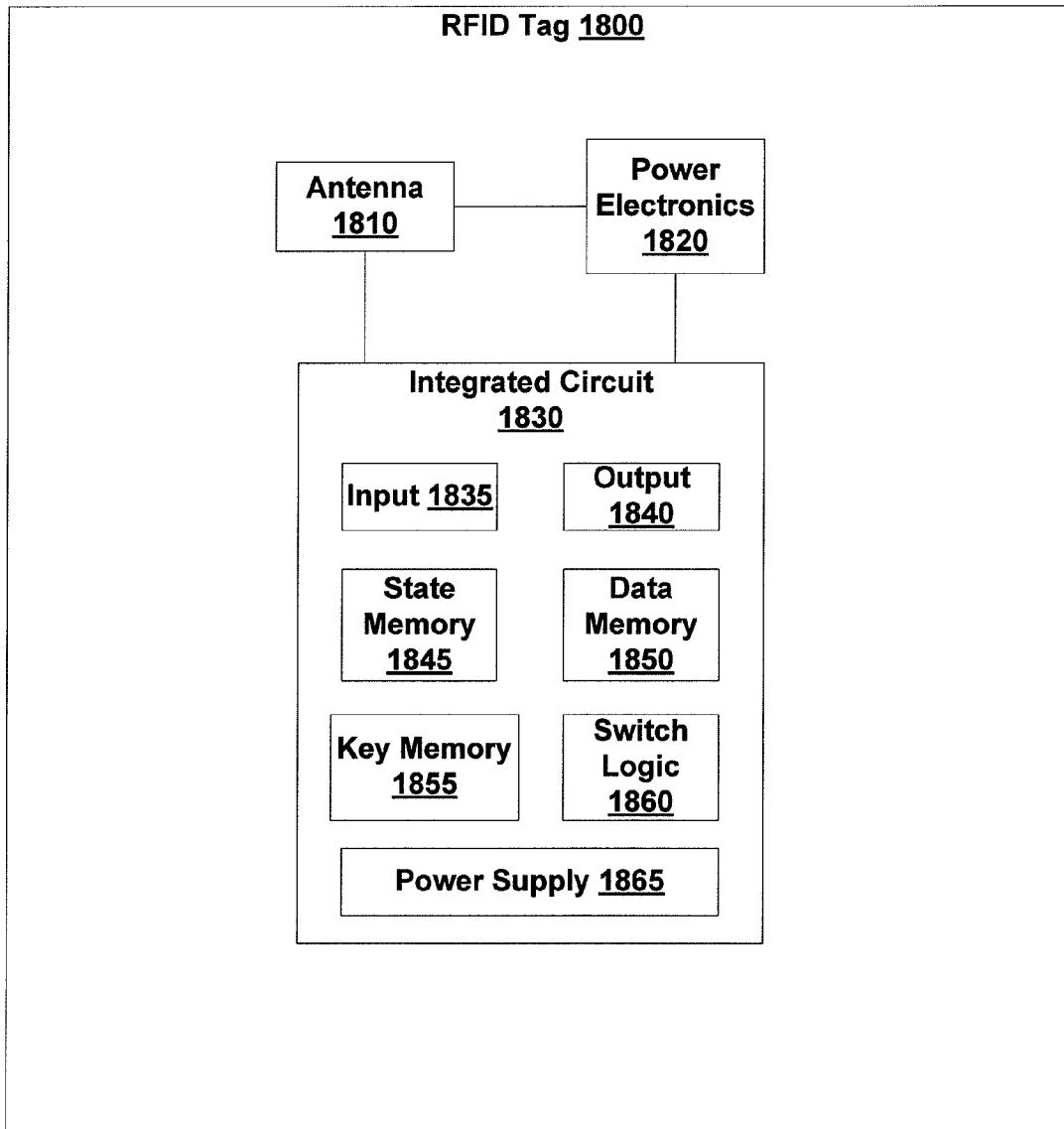

FIG. 18

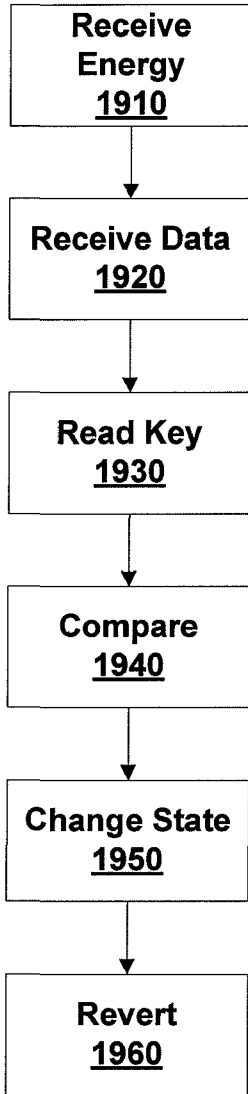

FIG. 19

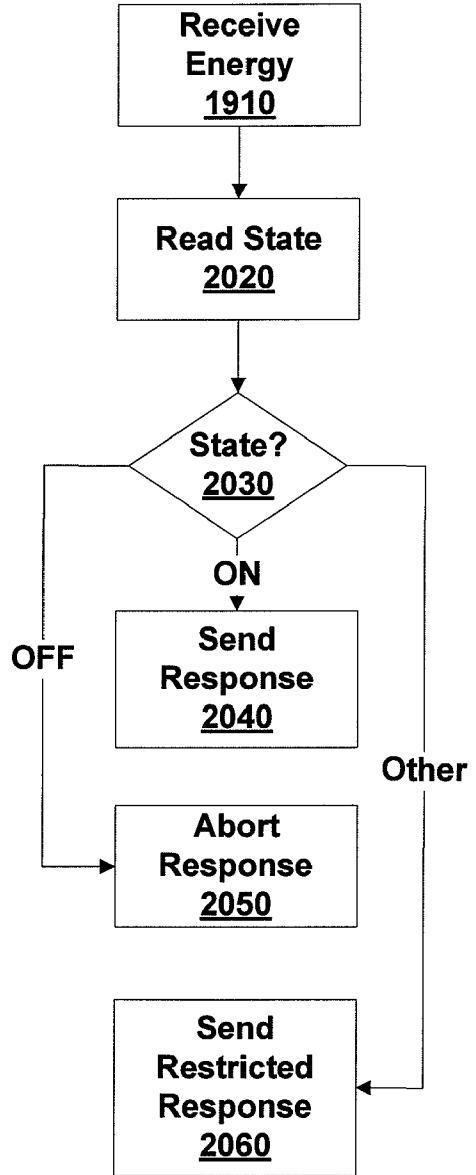

FIG. 20

## ELECTRONICALLY SWITCHABLE RFID TAGS

### CROSS-REFERENCE TO RELATED APPLICATIONS

This application is

a continuation-in-part of U.S. nonprovisional application Ser. No. 11/382,050 filed May 7, 2006 which in turn claims benefit and priority to U.S. provisional patent applications:

60/678,428 filed May 6, 2005; and

60/685,331 filed May 27, 2005;

a continuation-in-part of U.S. nonprovisional application Ser. No. 11/382,052 filed May 7, 2006;

a continuation-in-part of U.S. nonprovisional application Ser. No. 11/382,053 filed May 7, 2006;

a continuation-in-part of U.S. nonprovisional application Ser. No. 11/382,054 filed May 8, 2006;

a continuation-in-part of U.S. nonprovisional application Ser. No. 11/382,265 filed May 8, 2006;

a continuation-in-part of U.S. nonprovisional application Ser. No. 11/382,264 filed May 8, 2006;

a continuation-in-part of U.S. nonprovisional application Ser. No. 11/420,721 filed May 26, 2006; and claims benefit of U.S. provision patent applications:

60/700,884 filed Jul. 19, 2005;

60/712,308 filed Aug. 30, 2005;

60/715,641 filed Sep. 10, 2005;

60/752,933 filed Dec. 21, 2005;

60/758,751 filed Jan. 13, 2006;

60/782,068 filed Mar. 13, 2006;

60/744,154 filed Apr. 3, 2006, and

60/746,636 filed May 6, 2006.

The disclosures of the above provisional and nonprovisional patent applications are hereby incorporated herein by reference.

The disclosure of U.S. nonprovisional patent application Ser. No. 11/350,309 filed Feb. 7, 2006 is hereby incorporated herein by reference.

### BACKGROUND OF THE INVENTION

#### 1. Field of the Invention

The invention is in the field of electronic devices and more specifically in the field of radio frequency identification (RFID) tags.

#### 2. Description of Related Art

RFID tags are typically small, flexible, and low profile devices that can be affixed to items for electronic tracking and information storage purposes. An RFID tag can be read by an RFID reader when the RFID tag is brought within a certain vicinity of the reader while the reader is broadcasting an appropriate signal. In some cases, once within that vicinity, the RFID tag receives sufficient power from the broadcast signal to permit the RFID tag to transmit a return radio frequency signal. This type of RFID tag is referred to as a passive RFID tag because it does not include an independent power source. Passive RFID tags may receive power either via a radio frequency signal (e.g., radio waves) or through electromagnetic induction. Typically, electromagnetic induction is easier to implement but operates over a shorter range. Electromagnetic induction may operate at lower frequencies than RF powered RFID tags. In other cases an RFID tag includes an independent power source for generating a radio frequency signal. This type of RFID tag is referred to as an active RFID tag.

RFID tags generate a return radio frequency signal that may include an encoded copy of information stored within the RFID tag. As RFID tags achieve more wide spread use they will become ubiquitous on forms of tagging, labeling, identification, and be included in personal and business effects, such as passports, driver's licenses, keys, cell phones, credit cards, PDAs, and so forth. For example, an RFID tag may be incorporated in a driver's license to store personal information about the licensee or in a product label to track inventory.

A problem with using RFID tags to store security, confidential and/or personal information is that an RFID reader can read any RFID tags that pass within its range. Even if data is encrypted, this creates a possibility of unauthorized access to the personal data and other information stored in the RFID tag.

### BRIEF DESCRIPTION OF DRAWINGS

FIG. 1 is a block diagram of a switchable RFID device, according to various embodiments of the invention;

FIGS. 2 and 3 illustrate some of many possible locations for a switch within a switchable RFID device, according to various embodiments of the invention;

FIG. 4A illustrates an OFF Position of a switch, according to various embodiments of the invention;

FIG. 4B illustrates an ON position of a switch, according to various embodiments of the invention;

FIGS. 5A and 5B illustrates a membrane switch, according to various embodiments of the invention;

FIG. 5C illustrates an embodiment of a membrane switch including a spring, according to various embodiments of the invention;

FIG. 5D illustrates a cross-sectional view of a membrane switch disposed within a switchable RFID Tag, according to various embodiments of the invention;

FIG. 6 illustrates a top view of a membrane switch, according to various embodiments of the invention;

FIG. 7 illustrates a switchable RFID tag in an identity document, according to various embodiments of the invention;

FIG. 8 illustrates the manufacture of instances of an identity document, according to various embodiments of the invention;

FIG. 9 illustrates an exploded view of an embodiment of a switchable RFID device including a driver's license, according to various embodiments of the invention;

FIG. 10 illustrates an embodiment of a switchable RFID Device including a plurality of switches, according to various embodiments of the invention;

FIG. 11 illustrates various embodiments of an tag configured for use in embodiments of a switchable RFID device including a plurality of switches, according to various embodiments of the invention;

FIG. 12 illustrates an instance of a tag, according to various embodiments of the invention;

FIG. 13 illustrates a method according to various embodiments of the invention, according to various embodiments of the invention;

FIG. 14 illustrates a switchable RFID device configured to operate as a remote control, according to various embodiments of the invention;

FIG. 15 illustrates a multiswitch credit card, according to various embodiments of the invention;

FIGS. 16A-16C illustrate an antenna within a credit card, according to various embodiments of the invention;

FIG. 17 illustrates an RFID device including a conductor configured to set a state of an RFID tag, according to various embodiments of the invention.

FIG. 18 is a block diagram illustrating an RFID tag, according to various embodiments of the invention;

FIG. 19 is a flowchart illustrating a method of changing a state of the RFID tag illustrated in FIG. 1, according to various embodiments of the invention; and

FIG. 20 is a flowchart illustrating a method of operating the RFID tag illustrated in FIG. 1, according to various embodiments of the invention.

### SUMMARY

Various embodiments of the invention include a remotely powered RFID (radio frequency identity) tag having an electronically controlled switch. This switch is optionally a remotely (wirelessly) controlled switch. In some embodiments, when the switch is in an off state, the RFID tag will not transmit and when the switch is in an on state the RFID tag will transmit in response to an RF (radio frequency) signal. In some embodiments, the switch includes multiple on states in which different information or signals are transmitted responsive to the state of the switch. The RFID tag includes a memory configured to store the states of the RFID tag and an integrated circuit configured to determine whether to transmit responsive to the stored state of the RFID tag and a received RF signal.

Various embodiments of the invention include switchable RFID devices. These switchable RFID devices can include identity documents such as passports or driver's licenses, financial cards such as credit or debit cards, remote controls, security devices, access devices, communication devices, or the like. In some embodiments, more than one switchable RFID tag is included in a single RFID device. In various embodiments, one or more switches are used to change operation of an RFID tag from a responsive state to a non-responsive state, to change operation of an RFID tag from one responsive state to another responsive state, to enter data into an RFID device, to control an external device, or the like. In various embodiments, the switches are electronic, wireless, and/or mechanical.

Various embodiments of the invention includes an RFID tag comprising an antenna configured to receive data in a first RF signal, to receive energy from the first RF signal, and to transmit data in a second RF signal, the transmission of the second RF signal being powered by the energy received from the first RF signal; and an integrated circuit including an input configured to receive data from the antenna and to receive power resulting from the energy received from the antenna, an output configured to provide an RF signal to the antenna for transmission, a state memory configured to store an ON/OFF state of the RFID tag, a key memory configured for storing a key for changing the ON/OFF state stored in the state memory, and a switch logic configured to receive data from the input, to read the key from the key memory, to compare the received data with the read key, and to change the ON/OFF state stored in the state memory responsive to this comparison, the switch logic is further configured to determine whether or not to provide a second RF signal to the antenna for transmission, the determination being responsive to the ON/OFF state stored in the state memory.

Various embodiments of the invention include a method of changing an ON/OFF state of an RFID Tag, the method comprising receiving energy sufficient to power the RFID Tag through an RF antenna included in the RFID tag, receiving first data through the RF antenna, reading a key from a key

memory, using an integrated circuit to compare the first data received through the RF antenna with the key read from the key memory, the integrated circuit powered by the received energy, and writing data to state memory responsive to the comparison, the data written to the state memory being configured to change the RFID tag from an OFF state in which the RFID tag will not transmit an RF signal to an ON state in which the RFID tag will transmit an RF signal.

Various embodiments of the invention includes a method of operating an RFID tag, the method comprising receiving energy sufficient to power the RFID tag through an RF antenna included in the RFID tag, reading a state from state memory, sending an RF response through the RF antenna unless the read state is an OFF state.

Various embodiments of the invention includes a method of operating an RFID tag, the method comprising receiving energy sufficient to power the RFID tag through an RF antenna included in the RFID tag, reading a state from state memory, sending an RF response through the RF antenna if the read state is an ON state, and disabling the RF response through the RF antenna if the read state is an OFF state.

Various embodiments of the invention includes a method of operating an RFID tag, the method comprising receiving energy sufficient to power the RFID tag through an RF antenna included in the RFID tag, reading a state from state memory, sending an RF response through the RF antenna only if the read state is an ON state.

Various embodiments of the invention includes a multi-layer identity document comprising a first outer layer, an electrical conductor configured to conduct a current, a spacer layer including an opening configured to contain a switch activator, the switch activator configured to make and break an electrical connection to the electrical connector, and an inner layer disposed such that the spacer layer and switch activator are between the first outer layer and the second outer layer, the inner layer being configured to be pressed to activate the switch activator.

Various embodiments of the invention includes a switchable RFID tag comprising an antenna configured to receive an RF transmission, an integrated circuit configured to generate a response transmission, and a switch configured to turn on and of the ability of the integrated circuit to generate the response transmission, the switch being disposed such that it is surrounded by the antenna.

Various embodiments of the invention includes a system comprising a plurality of switches configured for a user to enter data, logic configured to transmit a first wireless signal responsive to the entered data, and a circuit configured to receive energy from a received second wireless signal and to power the logic and the transmission of the system using the received energy.

Various embodiments of the invention includes a system comprising logic configured to transmit a first wireless signal in response to a received second wireless signal, a wireless I/O configured to receive the second wireless signal and to transmit the first wireless signal, a memory configured to store an account number, the account number being included in the first wireless signal, a physical contact I/O configured for writing the account number to the memory, logic configured to allow writing of the account number to the memory if the account number is received via the physical contact I/O but if the account number is received via the wireless I/O, and a circuit configured to receive energy from the received second wireless signal and to power the logic and the transmission of the first wireless signal using the received energy.

Various embodiments of the invention includes a system comprising logic configured to transmit a first wireless signal



5

in response to a received second wireless signal, a wireless I/O configured to receive the second wireless signal and to transmit the first wireless signal, the second wireless signal including an identification data associated with a reader, a memory configured to store a log of received identification data received from a plurality of readers, a physical contact I/O configured for uploading the log of received identification data from the memory, logic configured to allow uploading of the log of received identification data from the memory via the physical contact I/O but via the wireless I/O, and a circuit configured to receive energy from the received second wireless signal and to power the logic and the transmission of the first wireless signal using the received energy.

Various embodiments of the invention includes a method comprising mounting a plurality of RFID antenna and RFID tags on a support, mounting a the support on a first side of a spacer, the spacer including opening **140** and optionally including one or more cavity to receive the RFID tags, mounting a cover layer on a second side of the spacer, and cutting the support and spacer to generate a plurality of RFID enabled financial Cards.

Various embodiments of the invention include a method comprising mounting an RFID antenna and RFID tag on a support, mounting a spacer on the support, the spacer being compliant (soft) so that the RFID tag can enter a plane of the spacer to form a cavity, allowing the spacer to harden, and mounting a cover layer on the spacer.

Various embodiments of the invention include a method of assembling an identity device, the method comprising depositing an integrated circuit, antenna and switch contacts on a support layer, and laminating the support layer, spacer and flexible membrane together, the spacer having a cavity in which the integrated circuit fits.

Various embodiments of the invention include a method of assembling an identity device, the method comprising depositing an integrated circuit, antenna and switch contacts on a support layer **150**, depositing spacer **120** on the support layer, spacer **120** covering the integrated circuit, and depositing a flexible membrane on the support layer, the flexible membrane or the support layer optionally including an image of a user. The Spacer is optionally configured to create a hermetic seal around the integrated circuit and/or the RFID antenna.

Various embodiments of the invention include a method comprising programming data to non-volatile memory of an RFID tag in a programmable mode, and changing a state of a switch coupled to the RFID tag so as to change the RFID tag from the programmable mode to a non-programmable mode.

Various embodiments of the invention include an RFID tag comprising an antenna configured to transmit data, a power circuit configured to provide power, an integrated circuit configured to receive power from the power circuit, to provide the data to the antenna, the integrated circuit including a non-volatile memory configured to store the data and a logic circuit configured to determine a state of a switch, the switch being configured to control whether the volatile memory can or cannot be programmed.

Various embodiments of the invention include an integrated circuit comprising a first logic input configured for determining a state of a switch, a power input configured to receive power from a radio frequency antenna, the received power being sufficient for powering the integrated and transmitting a data output signal via the radio frequency antenna, and a data output configured for generating the data output responsive to the state of the switch as determined by the first logic input.

Various embodiments of the invention include an Identity Device comprising an RFID antenna configured to receive

6

power from and communicate with an RFID reader, a circuit configured to receive power from the RFID Antenna, a tag configured to be powered by power received through the RFID antenna and to generate a signal for transmission between the RFID antenna and the RFID reader, and a switch configured to repeatedly turn on and turn off detectability or readability of the tag.

Various embodiments of the invention include a locking mechanism comprising a RFID tag activation circuit configured to turn on a switchable RFID tag by operating a switch within the switchable RFID tag, an RFID reader configured to read the switchable RFID tag, and a lock configured to open responsive to the RFID reader.

Various embodiments of the invention include a method of operating an RFID tag, the method comprising activating a switch in order to turn on the detectability or readability of the RFID tag, the RFID tag powered by power received through an RFID antenna, and activating the switch in order to turn off the detectability or readability of the RFID tag.

Various embodiments of the invention include a method of operating a switchable RFID tag, the method comprising operating a switch to turn the RFID tag on, responsive to a first action of a user, receiving a signal at an RFID antenna, collecting power from the signal, using the collected power to power an integrated circuit, collecting data from the signal, processing the collected data using the integrated circuit, transmitting a signal generated by the integrated circuit in response to the collected data, using the RFID antenna, and operating the switch to turn the RFID tag off, responsive to a second action of a user.

Various embodiments of the invention include a switchable RFID tag comprising an RFID antenna configured to receive power from and communicate with an RFID reader, a tag configured to be powered by power received through the RFID antenna and to generate a signal for transmission between the RFID antenna and the RFID reader, and a switch configured to repeatedly turn on and turn off detectability or readability of the tag.

Various embodiments of the invention include a method of controlling an electronic device, the method comprising receiving a wireless RF signal from an RF transmitter, converting the received RF signal into electronic power, generating a wireless return signal using the electronic power, the wireless return signal configured to control the electronic device, placing a switch in a first position to turn on the generation of the wireless return signal, placing the switch in a second position to turn off the generation of the wireless return signal, and returning the switch to the first position to turn on the generation of the wireless return signal.

Various embodiments of the invention include a method of controlling an electronic device, the method comprising receiving a wireless RF signal from an RF transmitter; converting the received RF signal into electronic power; repeatedly changing a switch from a first position to a second position; and generating a wireless return signal using the electronic power, the wireless return signal configured to control the electronic device and being responsive to whether the switch is in the first position and the second position.

Various embodiments of the invention include a system comprising an antenna configured to receive a wireless RF signal from an RF transmitter, a power circuit configured to convert the RF signal into electronic power, a circuit configured to receive the electronic power and to send a wireless response signal in response to the RF signal, and a first switch configured to repeatedly turn on and off a first operation of the circuit under control of a user.

Various embodiments of the invention include a method of receiving control instructions, the method comprising, generating a wireless RF signal, transmitting the wireless RF signal to a RF powered remote control device configured to send a wireless return signal responsive to the states of one or more switches, the return signal being generated and transmitted using power converted from the wireless RF signal, receiving the return signal, and determining the states of the one or more switches using the received return signal.

Various embodiments of the invention include a system comprising a RF transmitter configured to send a wireless RF signal, a controlled device, a RF powered remote control configured to be powered by the wireless RF signal and to send a wireless response signal to the controlled device responsive to a first switch, the first switch configured to be repeatedly turned on and off by a user.

Various embodiments of the invention include a method of operating an RFID tag, the method comprising receiving energy sufficient to power the RFID tag through an RF antenna included in the RFID tag, reading a state from state memory, and sending an RF response through the RF antenna unless the read state is an OFF state.

Various embodiments of the invention include a method of operating an RFID tag, the method comprising receiving energy sufficient to power the RFID tag through an RF antenna included in the RFID tag, reading a state from state memory, sending an RF response through the RF antenna if the read state is an ON state, and disabling the RF response through the RF antenna if the read state is an OFF state.

Various embodiments of the invention include a method of operating an RFID tag, the method comprising receiving energy sufficient to power the RFID tag through an RF antenna included in the RFID tag, reading a state from state memory, sending an RF response through the RF antenna only if the read state is an ON state.

#### DETAILED DESCRIPTION

FIG. 1 is a block diagram of a Switchable RFID Device 100. In some embodiments, Switchable RFID Device 100 is an identity device such as a passport, identity card, driver's license, immigration document (e.g., green card or visa), student identity card, library card, financial card (e.g., credit card, debit card or prepaid card), social security card, Military ID card, key, keycard or the like. Switchable RFID Device 100 optionally includes Visible Indications 120 such as a barcode, picture, image, name, address, text, and/or the like. Switchable RFID Device 100 further includes one or more Switchable RFID Tag 130. Switchable RFID Tag 130 includes one or more RFID Antenna 140, a Circuit 150, one or more Tag 160 and one or more Switch 170. Switch 170 is optionally disposed within Circuit 150 or Tag 160. RFID Antenna 140 is configured for sending a radio frequency (RF) signal from Switchable RFID Device 100 in response to a received signal. The received signal is optionally used to power Switchable RFID Tag 130. In some embodiments, the received signal is an RF signal received by RFID Antenna 140. In alternative embodiments, the received signal is received through an inductive coupling or a non-RF antenna within Circuit 150. RFID Antenna 140 is optionally a dipole antenna.

In some embodiments, Switchable RFID Tag 130 is configured for a user to be able to repeatedly turn on and off the function (e.g., delectability or readability) of Tag 160 using Switch 170. Circuit 150 typically further includes a diode, capacitor, transistor, and/or the like configured to receive power through RFID Antenna 140 or an inductive coupling

and to convey signals between RFID Antenna 140 and Tag 160. In some embodiments, Tag 160 includes an integrated circuit.

Switchable RFID Tag 130 is differentiated from circuits found in RFID tags of the prior art by at least the inclusion of Switch 170. Switch 170 is optical, thermal, magnetic, mechanical, wireless, and/or electronic. Switch 170 is configured to be activated by a magnetic field, an electric field, a wireless signal, light, heat, mechanical force, and/or an electronic circuit external to Switchable RFID Device 100. Switch 170 is optionally a sliding switch, a flip switch, a rotating switch, membrane switch, pushbutton switch, or other mechanical switch known in the art of mechanical switches. In typical embodiments, Switch 170 is configured for both turning on and turning off function of Tag 160.

In various embodiments, Switch 170 is normally open or normally closed, and the function of Tag 160 can be normally on or normally off. For example, In some embodiments, Switch 170 is a mechanical contact switch activated by applying pressure to an outside surface of Switchable RFID Device 100. In some embodiments, when this pressure is applied the functionality of Tag 160 will be turned on, and when this pressure is not applied the functionality of Tag 160 will be off. In some embodiments, Switch 170 is a mechanical contact switch activated using a magnetic field. In some embodiments, Switch 170 is an electrical switch turned on or off by a circuit external to Switchable RFID Device 100. For example, Switch 170 may include two electrical contacts exposed at the exterior of Switchable RFID Tag 130. When a conductance path, current and/or voltage is applied between these electrical contacts Switch 170 is turned on, or in alternative embodiments, turned off.

In various embodiments, Switch 170 functions by creating a short circuit. For example, Switch 170 can be configured to turn off the function of Tag 160 by short circuiting RFID Antenna 140, a diode within Circuit 150, a capacitor within Circuit 150, a transistor within Circuit 150, and/or a connection within Tag 160.

In various embodiments, Switch 170 functions by creating an open circuit. For example, Switch 170 can be configured to create an open circuit between (or within) RFID antenna 140, Circuit 150, and/or Tag 160.

In some embodiments, Switchable RFID Device 100 is configured to operate as a key and Switch 170 is activated to turn on the functions of Tag 160 by mechanical insertion of the key into a locking device. In these embodiments, the functions of Tag 160 are typically off when the key is not inserted in the locking device. The locking device is configured to activate Switch 170 using an electronic circuit, a mechanical force, or a magnetic field.

In alternative embodiments, an instance of Switch 170 is included in Tag 160 and/or Circuit 150. Thus, Switchable RFID Tag 130 may include a plurality of Switch 170, one Switch 170 in Circuit 150 and one Switch 170 in Tag 160. As is described further herein, these instances of Switch 170 may be configured to perform different functions.

FIG. 2 illustrates some of many possible locations for Switch 170 within Switchable RFID Device 100 where Switch 170 creates an open circuit. FIG. 3 illustrates some of many possible locations for Switch 170 within Switchable RFID Device 100 wherein Switch 170 creates a short circuit. The embodiments illustrated by FIGS. 2 and 3 include a Transistor 210, a Diode 220, and a Capacitor 230. Possible positions for Switch 170 are indicated by an "X."

In some embodiments, Switch 170 is configured to partially limit the functionality of Tag 160. Thus, Tag 160 may be configured to respond with data indicating a first state when

Switch 170 is on and to respond with data indicating a second state when Switch 170 is off. For example, Switch 170 can be connected to logic circuits of Tag 160 in such a way that Tag 160 will transmit a limited amount of data when Switch 170 is off and a less limited amount of data when Switch 170 is on. For example, Tag 160 may be configured to respond with data indicating the name of a person when Switch 170 is off and to respond with the data including the name, an address, an account number and a telephone number when Switch 170 is on. When Switch 170 is connected to a circuit within Tag 160, Switch 170 (or a plurality thereof) is optionally configured to separately control detection of and readability of Tag 160. Detection occurs when Tag 160 sends any response signal, while readability is a function of the data that may be included in the contents of the response signal.

FIGS. 4A and 4B illustrate one embodiment of Switchable RFID Device 100 in which Switch 170 is a sliding switch disposed along an Edge 420 of Switchable RFID Device 100. FIG. 4A illustrates an OFF Position wherein an Electrical Connector 410 between Circuit 150 and Tag 160 is in an open circuit state. In this state, Tag 160 is not normally detectable or readable. FIG. 4B illustrates an ON position wherein Switch 170 completes an electrical connection between Circuit 150 and Tag 160. In this position, Tag 160 is detectable and readable. In this embodiment, Switch 170 is configured to be moved between the on position and the off position, for example using a finger. In the on position, Switch 170 optionally extends from Edge 420 of Switchable RFID Device 100. In the off position, Switch 170 is optionally approximately flush with Edge 420. Some embodiments of the invention include a switch configured to be approximately flush with an edge of a financial card (e.g., credit card or debit card) in at least one position. Some embodiments of the invention include a switch configured to be below an edge of a financial card in at least one position. Switch 170 may be bistable or astable. Other features illustrated in FIGS. 4A and 4B are optional.

FIGS. 5A and 5B illustrates a Membrane Switch, generally designated 500, (and surrounding area) for use in a switchable RFID device such as Switchable RFID Device 100. Membrane Switch 500 is optionally an embodiment of Switch 170. Membrane Switch 500 is shown in the OFF and ON positions, in FIGS. 5A and 5B respectively. The use of a finger to operate Membrane Switch 500 is optional, other devices may be used to activate the switch. By bringing electrical conductors on a Surface 530 and a Surface 525 together, a switchable RFID tag is controlled, activated or deactivated. Typically, Surface 525 and Surface 530 are coated with an electrical conductor, such as copper. In some embodiments, a Support Layer 510 is disposed at a First Surface 515 of Switchable RFID Device 100 and a Flexible Membrane 520 is disposed at a Second Surface 535 of Switchable RFID Device 100. Thus, the Flexible Membrane 520 includes both Surface 525 and an outer surface, e.g., Surface 535 of Switchable RFID Device 100. In some embodiments, Surface 535 extends beyond Membrane Switch 500 to Surrounding Areas 550. As such Flexible Membrane 520 is essentially flush with a surface of Switchable RFID Device 100. Flexible membrane 520 and Support Layer are separated by a Spacer 540. In some embodiments, Spacer 540 extends beyond the immediate vicinity of Membrane Switch 500 to Surrounding Areas 550. Spacer 540 optionally extends essentially throughout Switchable RFID Device 100. As such, Surface 535 can be essentially smooth, e.g. does not include raised portions near Membrane Switch 500. Support Layer 510 is typically stiffer than Flexible Membrane 520.

In various embodiments, Membrane Switch 500 is included in an identity device such as a passport, driver's license, immigration card, key card, financial card, ID card, or the like. For example, In some embodiments, Membrane Switch 500 is included within a passport or other identity device having a clamshell configuration. In these embodiments, Flexible Membrane 520 is optionally disposed toward an interior of the identity device when the identity device is closed. In this position, Flexible Membrane 520 is protected from inadvertent contact and typically can only be pressed after the identity device is opened.

In various embodiments, Membrane Switch 500 is included in a financial card (e.g., a credit card, debit card or the like). In some of these embodiments, Flexible membrane 520 is essentially flush with Surrounding Areas 550 of the financial card including Surface 525, as illustrated in FIGS. 5A and 5B. In this position Membrane Switch 500 does not substantially stick out from First Surface 525 of the financial card and is, thus, protected by Surrounding Areas 550 from inadvertent activation. In some embodiments, Membrane Switch 500 is recessed below First Surface 535.

FIG. 5C illustrates an embodiment of Membrane Switch 500 further including a Spring 555. Spring 555 may be considered a switch activator. Spring has an activation height at which the spring center will spring into contact with the Support Layer 510 this activation height is typically below First Surface 535.

FIG. 5D illustrates a cross-sectional view of Membrane Switch 500 disposed within Switchable RFID Tag 130. Tag 160 is at least partially disposed within Spacer 540 and/or Support Layer 510. Spacer 540 and/or Support Layer 510 optionally include a cavity configured to receive Tag 160. In some embodiments, Tag 160 is deposited on Support Layer 510 before Spacer 540 is deposited on Support Layer 540. In these embodiments, Support Layer 540 is formed around Tag 160. In some embodiments, Spacer 540 is configured to hermetically seal Tag 160 and/or Membrane Switch 500.

In various embodiments, an Opening 570 within Membrane Switch 500 is less than or equal to 2.0 mm, 1.5 mm, 1.75 mm, 1.25 mm, 1.0 mm, 0.75 mm, or 0.5 mm thick as measured from Surface 525 to Surface 530.

The membrane switch illustrated in FIGS. 5A and 5C is optionally disposed such that Flexible Membrane 520 is approximately flush with, or recessed in, First Surface 535 of an identity device such as a driver's license or credit card. As such, Spacer 540 prevents the membrane switch from being activated when a force is applied to the entire first surface. For example, when the identity device is placed within a wallet and the wallet is compressed.

Spacer 540 optionally extends essentially throughout an identity device. For example, where Switchable RFID Device 100 is a credit card, Spacer 540 may extend to the outer edges of the credit card. Flexible Membrane 520 optionally includes a picture of a user and/or an indication of the location of Opening 570 in Spacer 540. In some embodiments, Flexible Membrane 520 is transparent and Spacer 540 includes a picture of a user or a credit card number. In some embodiments, Spacer 540 includes a cavity configured to fit an integrated circuit, the integrated circuit configured to operate as part of Tag 160 and optionally mounted on Support Layer 540. In some embodiments, Support Layer 540 includes conductive traces configured to connect Tag 160 to an RFID Antenna 140. In some embodiments, Spacer 540 is generally rectangular in shape, (e.g., in the shape of a financial card).

FIG. 6 illustrates a top view of Membrane Switch 500 of FIG. 5C, according to various embodiments of the invention. In these embodiments, the shape of the Opening 570 is con-

figured to prevent Spring 555 from rotating. A wide variety of alternative shapes may be used in alternative embodiments.

FIG. 7 illustrates Switchable RFID Tag 130 in an embodiment wherein Switchable RFID Device 100 includes an Identity Document 700 having a clamshell configuration (e.g., a passport). Switchable RFID Tag 130 may be included in a Cover 740, a Cover 730, or an interior page (not shown) of Identity Document 700. Identity Document 700 optionally includes Shielding 710. Flexible Membrane 520 is typically disposed such that it is on the interior of Identity Document 700 when Identity Document 700 is closed. See U.S. nonprovisional patent application Ser. No. 11/350,309 filed Feb. 7, 2006 for further details of Identity Document 700, according to some embodiments.

FIG. 8 illustrates the manufacture of instances of Identity Document 700. At one stage in the manufacturing process, Shielding 710 is dispensed in the form of a strip. The strip is laid down over what will be several separate instances of Identity Document 700 (after when the manufacturing is completed). A plurality of Switchable RFID Tag 130 are deposited, creating a device including several Switchable RFID Tag 130. The assembled material, including Shielding 710 is optionally cut to separate the locations where the instances of Switchable RFID tag 130 are deposited or to be deposited. As a result a plurality of Identity Document 700 are produced. Pages are optionally added to the assembled material prior to cutting. See U.S. nonprovisional patent application Ser. No. 11/350,309 filed Feb. 7, 2006 for further details, according to some embodiments.

In the above and other embodiments, Switchable RFID Tag 130 is optionally disposed such that the switch mechanism is accessed from the inside of Cover 730 or Cover 740, the inside being the sides that face each other when Identity Document 700 is closed. This orientation is optionally configured to reduce the probability of inadvertently activating Switch 170 when Identity Document 700 is closed. For example, in these embodiments, Flexible membrane 510 may be to the inside (of the closed Identity Document 700) and Support Layer 510 may be to the outside. Support Layer 510 optionally includes a stiffener in the region near Opening 570.

FIG. 9 illustrates an exploded view of an embodiment of Switchable RFID Device 100 including a Driver's License, generally designated 900. In this view, for clarity, Spacer 540 is removed and Flexible Membrane 520 is separated from Tag 160, RFID Antenna 140, Circuit 150 and Support Layer 510. A location of Membrane Switch 500 is indicated by Markings 920 visible at Flexible Membrane 520. Surface 535 is of uniform level across the face of Driver's License 900. As such, Switchable RFID Device 100 can smoothly be placed in a wallet and Membrane Switch 500 is protected from inadvertent activation by Spacer 540. Membrane Switch 500 is optionally disposed at least partially within RFID Antenna 140. A similar embodiment of Switchable RFID Device 100 may include a credit card or similar financial device.

FIG. 10 illustrates an embodiment of Switchable RFID Device 100 including a plurality of Switches, designated 1010, 1020 and 1030. These embodiments of Switchable RFID Device 100 may include an identity device, financial device, credit card, debit card, remote control, product label, communication device, or the like. Any of Switches 1010, 1020, and 1030 are optional. Switch 1030 is configured for turning Switchable RFID Device 100 ON and OFF. For example, as illustrated, Switch 1030 may be disposed in a connection between RFID Antenna 140 and a Power Circuit 1040. Power Circuit 1040 is an embodiment of Circuit 150 configured to generate electrical power from a received signal to power Tag 160.

Switch 1010 and Switch 1020 are configured to control processing logic within Tag 160. For example, in some embodiments, Switch 1010 and Switch 1020 are configured to provide Boolean (true/false) values to a logic circuit within Tag 160. Some embodiments include further switches (e.g., 3, 4, 6, 8, 10 or more) configured to control processing logic.

In various embodiments, the processing logic within Tag 160 can be configured to perform a wide variety of functions responsive to Switch 1010, Switch 1020, and any additional switches present. For example, in some embodiments, the processing logic is configured such that when Switch 1010 is activated a transaction amount is approved and when Switch 1020 is activated the transaction amount is disapproved. Alternatively, Switch 1010 and Switch 10 may be part of a set of switches used to enter a PIN (personal identification number), an encryption key, an amount, an authorization code, an RFID reader identification number, an identification number associated with Switchable RFID Device 100, a selection of a mode of Tag 160, text, numbers, and/or other data.

In some embodiments, data sent by Tag 160 using RFID Antenna 140 is responsive to Switch 1010 and/or Switch 1020. For example, in some embodiments, Tag 160 will send a different identification number depending on whether Switch 1010 or Switch 1020 is activated. In some embodiments, Tag 160 is configured to allow a transaction up to a certain value if neither Switch 1010 nor Switch 1020 is activated, and progressively higher values if Switch 1010 or Switch 1020 is activated. In some embodiments, Tag 160 is configured to require that Switch 1010 and Switch 1020 be activated in a specific combination, order and/or with a specific temporal pattern in order to perform some operation, e.g., a financial transaction.

While the embodiment of Switchable RFID Device 100 illustrated in FIG. 10 includes one instance of Tag 160, as discussed elsewhere herein, Switchable RFID Device 100 optionally includes more than one instance of Tag 160. When more than one instance of Tag 160 is present, a separate instance of Switch 1030 may be disposed between RFID Antenna 140 (or Circuit 150) and each instance of Tag 160. In this configuration, the instances of Switch 1030 may be used to select which instance of Tag 160 to activate. Switch 1010 and/or Switch 1020 may, likewise, be configured to select, activate or control different instances of Tag 160.

In some embodiments, Switchable RFID Device 100 includes a Memory 1050. Memory 1050 is optionally programmable. For example, in some embodiments, Memory 1050 is programmable using data entered through instances of Switch 1010 and Switch 1020. In some embodiments, Memory 1050 is changed from a write state to a read only state, using Switch 1010. In various embodiments, Memory 1050 is configured to store data to be broadcast, encryption information, data keys, values to be used in conjunction with data entered using Switch 1010, data for logic processing, identifying data, account data, mode data characterizing a mode of Switchable RFID Tag 130, or the like. Memory 1050 can be volatile or non-volatile, FLASH, SDRAM, ROM, DDRAM, DRAM, or the like. Some embodiments of the invention include an automated device configured to actuate Switch 170 in order to place Switchable RFID Tag 130 in a programmable mode.

FIG. 11 illustrates various embodiments of Tag 160 configured for use in embodiments of Switchable RFID Device 100 including a plurality of switches. In the illustrated embodiments, Tag 160 includes a First Logic Input 1110 and an optional Second Logic Input 1120, configured to be coupled to Switch 1010 and Switch 1020, respectively. First Logic Input 1110 and Second Logic Input 1120 are each

13

configured to be responsive to a different switch. First Logic Input **1110** and Second Logic Input **1120** are configured to control the function of Tag **160**.

For example, in some embodiments, Tag **160** is configured to output different data via a Data Input/Output **1140** depending on the state of Switch **1010** as determined by the First Logic Input **1110**. Tag **160** is optionally configured to output different data depending on whether a switch coupled to First Logic Input **1110** or a switch coupled to Second Logic Input **1120** is activated.

In some embodiments, the switches illustrated in FIG. **11** are membrane switches. In some embodiments, the switches illustrated in FIG. **11** are irreversible switches.

FIG. **12** illustrates an instance of Tag **160**, according to various embodiments of the invention. These embodiments include a plurality (e.g., 2, 3, 4, 8, 10, 12 or more) of switch inputs, such as First Logic Input **1110**, Second Logic Input **1120** and Third Logic Input **1230**. First Logic Input **1110**, Second Logic Input **1120** and Third Logic Input **1230** are configured to receive inputs from Switch **1010**, Switch **1020**, Switch **1030**, or the like, respectively. The state of connected switches (Switch **1010**, Switch **1020**, etc.) is monitored by an optional Switch State Monitor **1240** and a Processing Logic **1250**. Switch State Monitor **1240** is optionally a multiplexer, latch, logic circuit, or the like.

In some embodiments, Processing Logic **1250** is configured to process data received through a Data Input From Antenna **1260**, to receive power from a Power Input From Antenna **1130**, and to generate data for output through a Data Output to Antenna **1270** responsive to the states of Switch **1010**, Switch **1030**, etc. The generated data is optionally further responsive to data stored in Memory **1050** and/or data received from Data Input from Antenna **1260**.

The data received from Memory **1050** can include codes required for Processing Logic **1250** to generate specific data for communication through Data Output to Antenna **1270**. For example, in some embodiments, Tag **160** is configured to output an RF signal only if data in Memory **1050** matches a state of Switches **1010** and **1020**. In some embodiments, the state of switches is used to determine which of several different alternative RF signals to transmit. For example, if Switch **1010** is activated then a first signal is transmitted, if Switch **1020** is activated then a second signal is transmitted, and if no switches are depressed then no signal is transmitted or a third signal is transmitted. The first and second signals are optionally associated with different financial accounts and/or different functions.

Some embodiments of the invention include a multiswitch credit card including one or more instances of Tag **160**. This multiswitch credit card optionally is configured to be associated with more than one financial account and switches may be used to indicate which of the more than one financial account should be used for a transaction. In one example, the multiswitch credit card includes an instance of Tag **160** configured for engaging in a financial transaction responsive to Switch **1010** and also configured to operate an electronic lock responsive to Switch **1020**.

Some embodiments of the invention optionally include programming of Tag **160** to make associations with the one or more financial account. This programming can include entering data within Memory **1050**. Alternatively, Tag **160** is configured to include a plurality of exchangeable Memory **1050**. In these embodiments, Tag **160** is programmed to operate with different financial accounts and/or functions by inserting different instances of Memory **1050** within Switchable RFID Tag **130**. The multiswitch credit card is, thus, optionally a multi account credit card.

14

Some embodiments of Switchable RFID Device **100** are configured to include a plurality of Tag **160**. Each member of the plurality of Tag **160** may be responsive to one or more switches. In some embodiments, Switchable RFID Device **100** is configured to receive one or more replaceable instances of Tag **160**. In these embodiments, Switchable RFID Device **100** may be programmed by replacing an instance of Tag **160**. Multiple instances of Tag **160** optionally share one instance of RFID Antenna **140** and/or one instance of Memory **1050**.

FIG. **13** illustrates a method according to various embodiments of the invention. In these embodiments, power is received by Tag **160** through an RF or inductive signal in a Receive Power Step **1310**. The RF signal optionally includes data received in a Receive Data Step **1320**. The state of one or more of Switches **1010**, Switch **1020**, etc. is then determined in a Determine Switch State **1330** Step. This state is used to determine an RF response, of any, in a Determine Response Step **1340**. The RF response is then sent in a Send Response Step **1350**.

FIG. **14** illustrates various embodiments of the invention in which Switchable RFID Device **100** is configured as a RF Powered Remote **1400** configured to control external devices. This RF Powered Remote **1400** optionally does not require an internal power source (e.g., is powered wirelessly). Power is received from an RF (radio frequency) signal via RFID Antenna **140** and used to send a return signal, typically through the same instance of RFID Antenna **140**. RF Powered Remote **1400** uses one or more Switchable RFID Tag **130** to activate and deactivate or modify the return signal. The one or more Switchable RFID Tag **130** optionally share RFID Antenna **140**, power circuits, and/or processing logic. RF Powered Remote **1400** is typically a multifunction remote control.

RF Powered Remote **1400** is optionally used as part of a locking mechanism, such as in a vehicle lock or door lock. RF Powered Remote **1400** is optionally configured to control electronic equipment, such as a computing device, a video recording device, projector, a game, a stereo, or a television. RF Powered Remote **1400** is optionally configured to control a garage door opener.

As illustrated in FIG. **14**, a Transmitter **1410** is configured to send an RF signal to provide power to RF Powered Remote **1400**. This RF signal is received by RF Powered Remote **1400**. When a switch (e.g. a First Switch **1420** or a Second Switch **1430**), included in RF Powered Remote **1400**, is in a first position the received power is used to send a return signal from RF Powered Remote **1400** to the device being controlled, e.g. a Controlled Device **1440**. Transmitter **1410** is optionally included in Controlled Device **1440**. When First Switch **1420** and/or Second Switch **1430** is in a second position the received power is not used to send the return signal from the remote, or is used to send a different return signal. The return signal may include audio, RF, infrared light, visible light, or the like. First Switch **1420** and Second Switch **1430** are optionally embodiments of Switch **1010**, Switch **1020**, or Switch **1030**. In various embodiments, RF Powered Remote **1400** includes 1, 2, 3, 4 or more switches, such as First Switch **1420** and Second Switch **1430**. Typically, different switches are configured to control different functions of Controlled Device **1440**.

In some embodiments, First Switch **1420** and/or Second Switch **1430** are configured to control the collection of power from the RF signal. In some embodiments, First Switch **1420** and/or Second Switch **1430** are configured to prevent the power from flowing through an integrated circuit within the RF Powered Remote **1400**. In some embodiments, the First Switch **1420** and/or Second Switch **1430** are configured to

15

decouple an instance of RFID Antenna **140** within RF Powered Remote **1400**. In some embodiments, the First Switch **1420** and/or Second Switch **1430** are configured to prevent data transmission from RF Powered Remote **1400**. In some embodiments, First Switch **1420** and/or Second Switch **1430** are configured to control logic within an instance of Tag **160** within RF Powered Remote **1400**. In various embodiments, First Switch **1420** and/or Second Switch **1430** are normally on or normally off. In some embodiments, more than one switch is configured to control logic within the same integrated circuit.

The embodiments of RF Powered Remote **1400** illustrated in FIG. **14** include a Power Collection Circuit **1450** configured to convert the received RF signal to electrical power of the operation of one or more Tag **160**. RF Powered Remote **1400** is configured to power an integrated circuit, e.g., Tag **160**, and send a return signal using the electrical power produced by Power Collection Circuit **1450**. The RF Powered Remote optionally receives all of its electrical power from the Power Collection Circuit **1450**.

Depending on the state of Switch **1420** and/or Switch **1430**, Tag **160** may cause the return signal to be transmitted using a Return Signal Generator **1460**. Return Signal Generator **1460** is optionally included in Tag **160**. Return Signal Generator **1460** is optionally shared by a plurality of Tag **160** within RF Powered Remote **1400**. In some embodiments, Return Signal Generator **1460** includes an instance of RFID Antenna **140**.

First Switch **1420** and Second Switch **1430** each control Tag **160**, such that the return signal is responsive to the states of these, and optionally further, switches. For example, in some embodiments, if First Switch **1420** is on, then Tag **160** will include a first data in the return signal, and if Second Switch **1430** is on, then Tag **160** will include a second (typically different) data in the return signal.

The RF Transmitter **1410** and Controlled Device **1440** are optionally separate. For example, the RF transmitter may be included in an automobile and the controlled device may be a garage door.

In some embodiments, First Switch **1420** is activated by insertion of RF Powered Remote **1400** in part of a locking system.

In some embodiments, First Switch **1420** is coupled to a button configured for turning the volume of an electronic device up and/or Second Switch **1430** is coupled to a different button configured for changing a channel.

In some embodiments, RF Powered Remote **1400** is configured to unlock a car.

In various embodiments, RF Powered Remote **1400** includes a wireless keypad, a wireless computer mouse, a wireless keyboard, a wireless microphone, a key, a telephone, an identity document, or the like.

In some embodiments, RF Powered Remote **1400** is included in a hermetically sealed and/or waterproof housing. Because the RF powered remote is remotely powered, there is no necessity for a battery compartment or power plug.

First Switch **1420** and Second Switch **1430** may include a push-button switch, a membrane switch, a sliding switch, a magnetic switch, or any of the many other switches known in the art to make and break electrical connections. First Switch **1420** is optionally part of a roller, wheel or dial that makes and breaks an electrical connection as it is turned. First Switch **1420** and Second Switch **1430** are optionally embodiments of Switch **170**.

In some embodiments, a single instance of RF Transmitter **1420** is configured to power a plurality of Tag **160**. Each of this plurality of Tag **160** is optionally configured to control a separate electronic device or operate different functions in a

16

single electronic device. The plurality Tags **160** optionally included in the same RF Powered Remote **1400**.

In some illustrative embodiments, an instance of RF Transmitter **1410** is disposed within a vehicle dashboard and a plurality of Tag **160** are disposed within a steering wheel of the vehicle or rear view mirror. One of the plurality Tag **160** is configured to control an audio system and another of the plurality of switchable RFID tags is configured to control a climate system (e.g., air conditioner or heating). In some embodiments, the wireless response signals generated by both of these Tag **160** is received by a RF receiver and communicated to a circuit that then controls the separate electronic devices. In alternative embodiments, each of the separate electronic devices (e.g., audio system and climate system) includes a separate RF receiver configured to receive the response signals.

FIG. **15** illustrates an embodiment of Switchable RFID Device **100** including a Multiswitch Credit Card **1500**, according to various embodiments of the invention. Multiswitch Credit Card **1500** includes two or more switches, such as Switch **1510**, Switch **1511**, and optional Switch **1512**. Switches **1510**, **1511** and **1512** are optionally embodiments of Switch **1010** and Switch **1020**. Multiswitch Credit Card **1500** further includes one or more instances of Tag **160**, an optional instance of Circuit **150** configured to generate power for used by Tag **160**, and RFID Antenna **140**. In embodiments without Circuit **150**, Multiswitch Credit Card **1500** includes its own power source (not shown).

Switches **1510-1512** are each configured to make or break an electrical connection, the state of which can be determined by the resistance of electric current flow or the presence of a current or voltage. In some embodiments, Switches **1510-1512** are membrane switches, such as Membrane Switch **500**. In various embodiments, Multiswitch Credit Card **1500** including Switches **1510-1512** is less than 4, 3, 2, 1.5, 1, or 0.5 mm thick. In various embodiments, Switches **1510-1512** are essentially flush with a front surface of Multiswitch Credit Card **1500**.

In some embodiments, Circuit **150** is configured to generate electrical power from the RF signal received via RFID Antenna **140** for use by one or more instances of Tag **160**. In some embodiments, Circuit **150** and/or RFID Antenna **140** are shared by several instances of Tag **160** within Multiswitch Credit Card **1500**. In some embodiments, Multiswitch Credit Card **1500** is configured not to transmit an RF signal unless at least one of Switches **1510-1512** is activated. In some embodiments, Switches **1510-1512** are configured for entering an access code, such as PIN or password. The access code is optionally encoded by an order in which the states of switches are changed, by a switch combination, and/or by a temporal relationship between changes in switch state, e.g., a temporal pattern.

In some embodiments, Switches **1510-1512** are configured for approving the amount of a financial transaction. In some embodiments, Switches **1510-1512** are configured for selecting from among a plurality of financial accounts. For example, activating Switch **1510** may result in a transaction being debited from a checking account, activating Switch **1511** may result in a transaction being applied a first charge account, and activating Switch **1512** may result in a transaction being applied to a second charge account.

In some embodiments, Multiswitch Credit Card **1500** (or other embodiments of Switchable RFID Tag **100**) includes encryption logic configured to operate in response to the activation of switches. For example, the encryption logic may be configured to use data received via switches as an encryption or decryption key. The encryption logic may be config-

ured to encrypt data received via switches prior to transmission of this data. In some embodiments, Switchable RFID Tag **100** is configured to make use of rolling codes for security purposes. In these embodiments, synchronization of the codes is optionally be coordinated by a central server configured to communicate with point of sale stations. In some embodiments, a switch is activated using a biometric sensor. The features described herein with respect to various embodiments of Switchable RFID Tag **100**, such as Multiswitch Credit Card **1500**, may be included in other types of identity devices.

In various embodiments of the invention, an identity device includes both one or more electrical contact configured to make physical electrical contact with a reader and a RFID tag configured to communicate wirelessly with a reader. The physical contact is optionally used to convey communication that is different from the wireless communication. For example, the physical connection based communication may include programming of a circuit within the RFID tag (e.g., programming account number), while the wireless communication may be more limited than the physical connection based programming, (e.g., the wireless communication may be limited to reading the programmed account number). In another example, the wireless communication may be configured for a limited set of transaction types (e.g., those less than \$50, or deposits), while the physical communication is configured for additional transaction types (e.g., larger value withdrawals). Further, the physical communication may be used for downloading transaction logs or other data stored on the ID card. Transaction logs are optionally stored using power received through RFID Antenna **140**.

In various embodiments, an identity device includes a plurality of switches and is configured to engage in a transaction or allow access (to an account, data, or a physical location) responsive to whether proper members of the plurality of switches are pressed. For example, in one embodiment the ID card includes 10 switches configured for a user to enter a PIN (personal identification number) or password. Only when the proper data is entered using the plurality of switches will the ID card participate in certain functions, such as an electronic payment or opening of a lock. As described further herein, different numbers of switches are possible.

In various embodiments, an identity device includes logic configured to process data entered using a plurality of switches. This logic may, for example, prevent the identity device from transmitting an RF signal unless the entered data matches previously stored data, for example, if an entered PIN matches a stored access code. The logic may be responsive to the order of switches activated, combinations of switch activation (e.g., which switches are activated at the same time), or which of the plurality of switches are activated. Timing may be achieved through the use of appropriate RC (resistor-capacitor) circuits or a clock signal.

Various embodiments of the invention include a modified version of Basic Access Control. In these embodiments, the logic is configured to prevent the identity device from transmitting certain data unless the data entered using switches on the identity device matches an ID number of a RFID reader making a request. The logic may be configured to implement Basic Access Control, such as that used in electronic U.S. passports, but unlike the system used in current passports, the data entered is an ID of the reader and the data is entered at the passport (or other identity device) rather than at the reader.

In various embodiments, the identity device includes a plurality of switches configured for a user to enter data associated with a reader. For example, In some embodiments, the switches are configured to receive an ID number of a point of

sale (POS) device. Logic within the identity device may then use this ID number to assure that a transaction is communicated to the correct POS device. For example, if several vending devices are positioned adjacent to each other, the ID number of one of the vending devices may be entered in the identity device using the plurality of switches and the ID card may then be enabled to engage in a transaction with that particular vending device but not the other nearby vending devices.

Passwords, PINs, or the like received by the identity device through the plurality of switches are optionally stored in volatile memory within the identity device. When the identity device ceases to receive energy through an RF signal the data stored in this volatile memory is discarded (lost). In some embodiments, this data is stored in non-volatile memory and thus retained between RF transmissions.

In some embodiments, the identity device is configured to store an account balance in static memory. Logic within the identity device is optionally configured such that the account balance can only be increased using a physical connection, while the account balance can be debited using a wireless connection. Alternatively, logic within the identity device is optionally configured such that the account balance can only be debited using a physical connection.

Some embodiments of the invention include methods of purchasing using a switchable RFID. The identity device is placed within the reading range of a wireless POS device. One of a plurality of switches within identity device is activated such that an RFID tag will respond to an RF signal from the POS device. The RFID tag responds to the RF signal from the POS by energizing itself using the RF signal and generating a response RF signal. The responsive RF signal includes an account number such as a checking or savings account number, a credit card number, identity number, or the like, responsive to the switch.

FIGS. **16A-16C** illustrate positions of RFID Antenna **140** within Multiswitch Credit Card **1500**, according to various embodiments of the invention. As illustrated in FIG. **16A**, in some embodiments, RFID Antenna **140** is disposed such that Embossed Lettering or Numbering **1520** is inside of RFID Antenna **140**. In these embodiments, at least part of Switch **170** (or a plurality thereof) is optionally disposed inside of RFID Antenna **140**. As illustrated in FIGS. **16B** and **16C**, in some embodiments, RFID Antenna **140** is disposed primarily in the part of a credit card (e.g., the upper half) that does not include Embossed Lettering or Numbering **1520**. In these embodiments, Switch **170** (or a plurality thereof) may be disposed either inside and/or out side of RFID Antenna **140**. As illustrated in FIG. **16C**, when Switch **170** is disposed outside of RFID Antenna, Connections **1510** between Switch **170** and Tag **160** are optionally routed to avoid Embossed Lettering or Numbering **1520**. In some embodiments, Spacer **540** is comprised of a material that can be embossed to form raised lettering and numbering (e.g., a name and credit card number). In these embodiments, the manufacture of Embossed Lettering or Numbering **1520** can be made through Spacer **540**.

In some embodiments, of the invention, one or more instances of Switch **170** are configured to control whether Tag **160** (and/or associated memory) are in a programmable state or a non-programmable state. For example, when an instance of Switch **170** is in a first state writing to non-volatile memory within Tag **160** is allowed and when Switch **170** is in a second state writing to the non-volatile memory is not allowed but reading of the non-volatile memory may be allowed. In some embodiments, Switch **170** is initially in a state wherein the non-volatile memory can be written to and the switch is then

irreversible changed to a state wherein the non-volatile memory can no longer be written to.

The irreversible change optionally includes breaking of a conductor. For example, in some embodiments, an RFID enabled identity device is configured such that an instance of Switch 170 comprises a Conductor 1710 coupled to Tag 160. As illustrated in FIG. 17, when Conductor 1710 is unbroken Tag 160 is in a programmable state, e.g., non-volatile memory within Switchable RFID Tag 130 can be written to. After programming this conductor is broken and Tag 160 is thus irreversibly changed to a nonprogrammable state. Data already programmed within Switchable RFID Tag 130 may be locked by the breaking of Conductor 1750. In one embodiment, Conductor 1710 is broken through the manufacture of Embossed Lettering or Numbering 1520. For example, embossing a credit card number into a credit card can break a conductor and thus lock the contents of non-volatile memory within the credit card. In alternative embodiments, an identity device includes a plurality of Conductor 1710 and members of this plurality are broken in order to program function of Tag 160. Each member of the plurality of Conductor 1710 that is or is not broken represents one bit of logic programmed.

Some embodiments of the invention include a switchable RFID tag is configured to be remotely switched using an RF signal. In some embodiments, in an OFF state, the RFID tag will not transmit a response signal and thus is not remotely detectable using an RF signal. In an ON state, the RFID tag will transmit a response signal. The RFID tag is switched between the ON state and the OFF state through receipt of a specific command or commands, through an RF signal. In alternative embodiments, the RFID tag includes multiple ON states, optionally in combination with an OFF state.

FIG. 18 illustrates a remotely switchable RFID Tag 1800 including an Antenna 1810, a Power Electronics 1820, and an Integrated Circuit 1830. RFID Tag 1800 is optionally an embodiment of other RFID tags disclosed herein. Likewise, Antenna 1810, Power Electronics 1820 and Integrated Circuit 1830 are optionally embodiments of other antennae, power electronics and integrated circuits disclosed herein. Antenna 1810 is configured to send and receive data encoded in an RF signal and also optionally configured to receive sufficient energy to power RFID Tag 1800.

Power Electronics 1820 are configured to receive energy through Antenna 1810 and to power Integrated Circuit 1830 using this received energy. Power Electronics 1820 typically include elements such as a diode, capacitor, transistor, or the like.

Integrated Circuit 1830 includes an Input 1835 configured to receive data from Antenna 1810 and power from Power Electronics 1820. Integrated Circuit 1830 further includes an Output 1840 configured to convey data to Antenna 1810 for transmission as an RF signal.

Integrated Circuit 1830 further includes an optional State Memory 1845 configured to store the current state of the RFID Tag, e.g., ON or OFF. In various embodiments, State Memory 1845 includes a memory location in a static random access memory, a magnetic memory, or the like. In these embodiments, the state stored within State Memory 1845 is preserved without a constant source of power. In some embodiments, State Memory 1845 includes memory configured to store data only while power is available. In this embodiment, the ON state is typically temporary and automatically reverts to the OFF state after power is no longer available.

Integrated Circuit 1830 further includes an optional Data Memory 1850 configured to store data received through Antenna 1810, and/or to be transmitted using Antenna 1810.

The data stored in Data Memory 1850 may include a serial number of RFID Tag 1800, identification data, biometric data, medical information, license information, or the like.

Integrated Circuit 1830 further includes a Key Memory 1855 configured to store a key required to change the state of the RFID Tag 1800 from ON to OFF, from OFF to ON, and/or between two ON states. Key Memory 1855 is typically static memory, and optionally read only memory or write-once memory. In other embodiments, the Key Memory 1855 is memory configured for temporary storage of data.

Integrated Circuit 130 further includes Switch Logic 1860 configured to read the state stored in State Memory 1845 and, responsive to the read state, either transmit or not transmit an RF signal using Antenna 1810. The transmitted data optionally includes data stored in Data Memory 1850. In some embodiments, Switch Logic 1860 is configured to not transmit an RF signal unless the state read from State Memory 1845 indicates that the RFID Tag is in an ON state. In some embodiments, Switch Logic 1860 is configured to read the state stored in State Memory 1845 and, responsive to the read state, transmit one of a plurality of alternative data stored in Data Memory 1850. In some embodiments, Switch Logic 1860 is configured to read the state stored in State Memory 1845 and, responsive to the read state, transmit different amounts of data stored in Data Memory 1850.

In some embodiments, Switch Logic 1860 is configured to receive data through Antenna 1810, to read a key from Key Memory 1855, to compare the received data with the read key, and to change the state stored in State Memory 1845 responsive to this comparison. For example, in some embodiments, if the read key matches the received data, the state of the RFID Tag 1800 is set to ON, or changed from one ON state to another ON state. In some embodiments, Switch Logic 1860 includes logic configured to decrypt or apply a hash function to the received data prior to the comparison. The Switch Logic 1860 can include software, hardware, and/or firmware. In some embodiments, State Memory 1845 is configured to store a rolling code.

In some embodiments, Integrated Circuit 1830 is embodied in several devices. For example, the functionality of Integrated Circuit 1830 may be distributed among several chips. In some embodiments, Key Memory 1855, Antenna 1810, Switch Logic 1860 and/or State Memory 1845 are configured to be shared by more than one instance of Integrated Circuit 1830. For Example, two or more instances of RFID Tag 1800 may be included in a single device and these two or more instances of RFID Tag 1800 may share a single instance of Key Memory 1855, Antenna 1810, Switch Logic 1860 and/or State Memory 1845.

In some embodiments, RFID Tag 1800 further includes a mechanical switch configured to control operation of RFID Tag 1800. This switch may include, for example, Switch 170 (FIG. 1). For example, in one embodiment, Switch Logic 1860 is configured for turning ON and OFF operation of RFID Tag 1800, while Switch 170 is configured to select between alternative ON states. In an alternative embodiment, Switch 170 is configured for turning ON and OFF operation of RFID Tag 1800 and Switch Logic 1860 is configured for selecting between alternative ON states. In some embodiments, proper activation of both Switch 170 and Switch Logic 1860 is required to turn RFID Tag 1800 to an ON state. Thus, in order for RFID Tag 1800 to transmit certain information, or to transmit at all, Switch 170 must be activated by a person and Switch Logic 1860 must receive a proper key from an RF reader. This provides a dual layer of mechanical and key based security. In some embodiments, the switch must be activated and a proper key must be received in order for RFID



Tag **1800** to transmit certain information. In some embodiments, use of Switch **170** will activate RFID Tag **1800** in a first ON state and use of Switch Logic **1860** (through an RF signal) will activate RFID Tag **1800** in a second ON state. The second ON state optionally requires use of both Switch **170** and Switch Logic **1860**.

In some embodiments, Integrated Circuit **1830** also includes an independent Power Supply **1865** such as a battery or capacitor.

In some embodiments, the switchable RFID Tag **1800** of FIG. **1** is included in an identification document such as a driver's license, green card, passport, or the like. In some embodiments, the Switchable RFID Tag **1800** is included in a wireless key configured to open a lock, to access data, to gain entry, or the like. In some embodiments, Switchable RFID Tag **1800** is included in a cellular telephone or another device configured to communicate using WiFi, WiMAX, or similar non-RFID standards.

FIG. **2** is a flowchart illustrating a method of changing a state of RFID Tag **1800**. In an optional Receive Energy Step **1910**, energy sufficient to power RFID Tag **1800** is received by Antenna **1810**. Receive Energy Step **1910** is typically similar to Receive Power Step **1310**. In a Receive Data Step **1920**, data is received by Antenna **1810** in the form of an RF signal. In some embodiments, Receive Data Step **1920** requires that a mechanical switch be activated. In a Read Key Step **1930**, a key is read from Key Memory **1855**. Optionally, the data received in the Receive Data Step **1920** is decrypted or otherwise processed. In a Compare Step **1940**, the read key is compared with the, optionally processed, data received in the Receive Data Step **1920**.

In a Change State Step **1950**, the state of RFID Tag **1800** is changed responsive to results of the comparison made in the Compare Step **1940**. In some embodiments, if there is a match between the key and the data then the state of RFID Tag **1800** is set to ON. Setting the state ON optionally includes writing a value to State Memory **1845**. In some embodiments, if there is no match between the key and the data then the state is set to OFF. In some embodiments, if there is a match between the key and the data, then the state is set to one of two or more possible ON states. In one of the two or more possible ON states, RFID Tag **1800** can transmit a response RF signal but the data that can be included in the response RF signal is restricted relative to another of the two or more possible ON states. For example, in one embodiment, in one ON state RFID tag **1800** is configured to include a name in the response RF signal, but another ON state RFID tag **1800** is configured to include the name and medical information in the response RF signal.

In some embodiments, RFID Tag **1800** is automatically returned to the OFF state from the ON state, in a Revert Step. For example, in one embodiment the ON state remains only so long as there is charge on a capacitor. When this charge dissipates or is used, the RFID automatically returns to a default OFF state. The automatic switch back to the OFF state can be dependent on when power is no longer received from an RF signal, on the timing characteristics of an RC (resistor-capacitor) circuit, on Switch **170**, on an RF signal received, and/or the like.

FIG. **20** is a flowchart illustrating a method of operating the RFID Tag **1800** illustrated in FIG. **18**. In an optional Receive Energy Step **1910** energy sufficient to power the RFID is received by Antenna **1810**. In a Read State Step **2020** the state of the RFID Tag is read from State Memory **145**. In a State? Step **2030** the read state is examined. If the read state is ON, then in a Send Response Step **2040** an RF response is sent from the RFID Tag **1800** using Antenna **1810**. If the read state

is OFF, then the RFID Tag **1800** is prevented from sending an RF response, in an Abort Response Step **2050**. In some embodiments, that include more than two states, the read state can be something other than ON or OFF. If the read state is a state other than ON or OFF then a restricted RF response is sent in a Send Restricted Response Step **2060**. The restricted response typically includes less or different data than would be included if the read state had been ON.

The steps shown in FIGS. **19** and **20** are optionally performed using Integrated Circuit **1830** of FIG. **18**.

In some embodiments, first data in a transmission is configured to change the state of an RFID tag to ON. Further data in the transmission is then configured to elicit a responding transmission from the RFID tag. After the transmission is concluded the RFID tag automatically reverts to the OFF state. These embodiments optionally include non-volatile memory for storage of the state.

In some embodiments, data in a transmission is configured to change the state of an RFID tag to ON. The ON state persists until the RFID tag receives data configured to change the state of the RFID tag to OFF.

Several embodiments are specifically illustrated and/or described herein. However, it will be appreciated that modifications and variations are covered by the above teachings and within the scope of the appended claims without departing from the spirit and intended scope thereof. For example, in some embodiments, Tag **160** is an active rather than a passive RFID tag. Examples discussed herein in relation to credit cards can equally be applied to other types of financial card such as a debit card, or prepaid card. For example, in some embodiments, RFID Tag **1800** is configured to change the ON/OFF state in response to a signal from a point of sale system indicating that an item has been sold. In these embodiments, RFID Tag **1800** is optionally configured to send different signals before and after a sale. A first of the different signals may be used to determine that the item has not yet been sold, and a second of the different signals may be used to determine that the item has been sold and/or may be returned. The features illustrated in FIGS. **18-20** are optionally included in embodiments illustrated by other figures of this application.

The embodiments discussed herein are illustrative of the present invention. As these embodiments of the present invention are described with reference to illustrations, various modifications or adaptations of the methods and or specific structures described may become apparent to those skilled in the art. All such modifications, adaptations, or variations that rely upon the teachings of the present invention, and through which these teachings have advanced the art, are considered to be within the spirit and scope of the present invention. Hence, these descriptions and drawings should not be considered in a limiting sense, as it is understood that the present invention is in no way limited to only the embodiments illustrated.

What is claimed is:

**1.** A RFID tag comprising:

- an antenna configured to receive data in a first RF signal, to receive energy from the first RF signal, and to transmit data in a second RF signal, the transmission of the second RF signal being powered by the energy received from the first RF signal; and
- integrated circuitry including
  - an input configured to receive data from the antenna and to receive power resulting from the energy received from the antenna,
  - an output configured to provide the second RF signal to the antenna for transmission,

23

a state memory configured to store an ON/OFF state including two or more ON states of the RFID tag; a key memory configured for storing a key for changing the ON/OFF state stored in the state memory, and a switch logic configured to receive data from the input, to read the key from the key memory, to compare the received data with the read key, and to change the ON/OFF state stored in the state memory responsive to this comparison, the switch logic being further configured to determine whether or not to provide the second RF signal to the antenna for transmission, the determination being responsive to the ON/OFF state stored in the state memory.

2. The RFID tag of claim 1, wherein the ON/OFF state of the RFID tag is OFF by default and temporally ON.

3. The RFID tag of claim 1, wherein the ON/OFF state of the RFID tag is stored in static memory.

4. The RFID tag of claim 1, wherein the determination is responsive to which of the alternative ON states are stored in the state memory.

5. The RFID tag of claim 1, wherein the RFID tag is disposed within a passport.

6. The RFID tag of claim 1, where in the state memory is configured to store in the alternative, an OFF state, a first ON state and a second ON state.

7. The RFID tag of claim 1, where in the state memory is configured to store a first value indicating an ON/OFF state and a second value indicating one of at least two alternative ON states.

8. The RFID tag of claim 1, wherein the RFID tag is disposed within a cellular telephone.

9. The RFID tag of claim 1, wherein the RFID tag is disposed within a passport, identity card, driver's license, immigration document, student identity card, library card, financial card, social security card, military ID card, key, keycard, or identification document.

10. The RFID tag of claim 1, wherein the RFID tag is disposed within a passport, driver's license, financial card, military ID card, key, or keycard.

11. A RFID tag comprising:  
 an antenna configured to receive data in a first RF signal, to receive energy from the first RF signal, and to transmit data in a second RF signal, the transmission of the second RF signal being powered by the energy received from the first RF signal; and  
 integrated circuitry including  
 an input configured to receive data from the antenna and to receive power resulting from the energy received from the antenna,  
 an output configured to provide the second RF signal to the antenna for transmission,  
 a state memory configured to store an ON/OFF state of the RFID tag,  
 a key memory configured for storing a key for changing the ON/OFF state stored in the state memory, and  
 a switch logic configured to receive data from the input, to read the key from the key memory, to compare the received data with the read key, and to change the ON/OFF state stored in the state memory responsive to this comparison, the switch logic being further configured to determine whether or not to provide the second RF signal to the antenna for transmission, the determination being responsive to the ON/OFF state stored in the state memory, wherein the state memory or switch logic are shared by two or more RFID tags.

12. The RFID tag of claim 11, wherein the antenna is shared by several RFID tags.

24

13. The RFID tag of claim 11, wherein the RFID tag is disposed within a cellular telephone.

14. A RFID tag comprising:  
 an antenna configured to receive data in a first RF signal, to receive energy from the first RF signal, and to transmit data in a second RF signal, the transmission of the second RF signal being powered by the energy received from the first RF signal; and  
 integrated circuitry including  
 an input configured to receive data from the antenna and to receive power resulting from the energy received from the antenna,  
 an output configured to provide the second RF signal to the antenna for transmission,  
 a state memory configured to store an ON/OFF state of the RFID tag, the ON/OFF state being responsive to timing using a resistor-capacitor circuit;  
 a key memory configured for storing a key for changing the ON/OFF state stored in the state memory, and  
 a switch logic configured to receive data from the input, to read the key from the key memory, to compare the received data with the read key, and to change the ON/OFF state stored in the state memory responsive to this comparison, the switch logic being further configured to determine whether or not to provide the second RF signal to the antenna for transmission, the determination being responsive to the ON/OFF state stored in the state memory.

15. The RFID tag of claim 14, wherein the ON/OFF state of the RFID tag is OFF by default and temporally ON.

16. The RFID tag of claim 14, wherein the ON/OFF state of the RFID tag is stored in static memory.

17. The RFID tag of claim 14, wherein the RFID tag is not remotely detectable using an RF signal when the ON/OFF state is OFF.

18. The RFID tag of claim 14, wherein the RFID tag is disposed within a cellular telephone.

19. The RFID tag of claim 14, wherein the RFID tag is disposed within a passport, identity card, driver's license, immigration document, student identity card, library card, financial card, social security card, military ID card, key, keycard, or identification document.

20. A RFID tag comprising:  
 a mechanical switch configured for selecting between two or more ON states of the RFID tag;  
 an antenna configured to receive data in a first RF signal, to receive energy from the first RF signal, and to transmit data in a second RF signal; and  
 integrated circuitry including  
 an input configured to receive data from the antenna,  
 an output configured to provide the second RF signal to the antenna for transmission,  
 a state memory configured to store a state of the RFID tag, and  
 a switch logic configured to receive data from the input, and to determine whether or not to provide the second RF signal to the antenna for transmission, the determination being responsive to the state stored in the state memory or the mechanical switch.

21. The RFID tag of claim 20, wherein the input is further configured to receive power resulting from the first RF signal and to power the integrated circuitry using the power.

22. The RFID tag of claim 20, wherein the integrated circuitry is configured for authorizing a transaction responsive to the mechanical switch.

## 25

23. The RFID tag of claim 20, wherein the mechanical switch must be activated and the state stored in the state memory must be an ON state before the second RF signal is transmitted.

24. The RFID tag of claim 20, further including a key memory configured for storing a key for changing the state stored in the state memory, the switch logic being further configured to read the key from the key memory, to compare the received data with the read key, and to change the state stored in the state memory responsive to the comparison between the received data with the read key.

25. The RFID tag of claim 20, wherein the RFID tag is disposed within a cellular telephone.

26. The RFID tag of claim 20, wherein the RFID tag is disposed within a cellular telephone.

27. The RFID tag of claim 20, wherein the RFID tag is disposed within a passport, identity card, driver's license, immigration document, student identity card, library card, financial card, social security card, military ID card, key, keycard, or identification document.

28. The RFID tag of claim 20, wherein the RFID tag is disposed within a passport, driver's license, financial card, military ID card, key, or keycard.

29. A RFID tag comprising:

a mechanical switch configured to set a state of the RFID tag stored in a state memory;

an antenna configured to receive data in a first RF signal, to receive energy from the first RF signal, and to transmit data in a second RF signal;

integrated circuitry including

an input configured to receive data from the antenna, an output configured to provide the second RF signal to the antenna for transmission,

the state memory configured to store the state of the RFID tag, and

a switch logic configured to receive data from the input, and to determine whether or not to provide the second RF signal to the antenna for transmission, the determination being responsive to the state stored in the state memory or the mechanical switch.

30. The RFID tag of claim 29, wherein the input is further configured to receive power resulting from the first RF signal and to power the integrated circuitry using the power.

31. The RFID tag of claim 29, wherein the integrated circuitry is configured for authorizing a transaction responsive to the mechanical switch.

32. The RFID tag of claim 29, wherein the RFID tag is disposed within a cellular telephone.

33. The RFID tag of claim 29, wherein the RFID tag is disposed within passport, identity card, driver's license, immigration document, student identity card, library card, financial card, social security card, military ID card, key, keycard, or identification document.

34. A RFID tag comprising:

a mechanical switch;

an antenna configured to receive data in a first RF signal, to receive energy from the first RF signal, and to transmit data in a second RF signal; and

integrated circuitry including

an input configured to receive data from the antenna, an output configured to provide the second RF signal to the antenna for transmission,

a state memory configured to store a state of the RFID tag, and

a switch logic configured to receive data from the input, and to determine whether or not to provide the second RF signal to the antenna for transmission, the deter-

## 26

mination being responsive to the state stored in the state memory or the mechanical switch, the state logic being further configured to store a plurality of alternative ON states, the mechanical switch being configured for switching the RFID tag from an OFF state to one of the plurality of alternative ON states.

35. The RFID tag of claim 34, wherein the input is further configured to receive power resulting from the first RF signal and to power the integrated circuitry using the power.

36. The RFID tag of claim 34, wherein the integrated circuitry is configured for authorizing a transaction responsive to the mechanical switch.

37. The RFID tag of claim 34, wherein the RFID tag is disposed within a cellular telephone.

38. The RFID tag of claim 34, wherein the RFID tag is disposed within a passport, identity card, driver's license, immigration document, student identity card, library card, financial card, social security card, military ID card, key, keycard, or identification document.

39. A RFID tag comprising:

a mechanical switch responsive to a state of a mechanical security device;

an antenna configured to receive data in a first RF signal, to receive energy from the first RF signal, and to transmit data in a second RF signal; and

integrated circuitry including

an input configured to receive data from the antenna, an output configured to provide the second RF signal to the antenna for transmission,

a state memory configured to store a state of the RFID tag, and

a switch logic configured to receive data from the input, and to determine whether or not to provide the second RF signal to the antenna for transmission, the determination being responsive to the state stored in the state memory or the mechanical switch.

40. The RFID tag of claim 39, wherein the integrated circuitry is configured for authorizing a transaction responsive to the mechanical switch.

41. The RFID tag of claim 39, wherein the RFID tag is disposed within a cellular telephone.

42. The RFID tag of claim 39, wherein the RFID tag is disposed within passport, identity card, driver's license, immigration document, student identity card, library card, financial card, social security card, military ID card, key, keycard, or identification document.

43. The RFID tag of claim 39, wherein the RFID tag is disposed within a passport, driver's license, financial card, military ID card, key, or keycard.

44. A method of changing a state of an RFID Tag, the method comprising:

receiving energy sufficient to power the RFID Tag through an RF antenna included in the RFID tag;

receiving first data through the RF antenna;

reading a key from a key memory;

using an integrated circuit to compare the first data received through the RF antenna with the key read from the key memory, the integrated circuit powered by the received energy;

determining a state of a mechanical switch in the RFID tag; and

writing data to state memory responsive to the comparison only if the mechanical switch is activated, the data written to the state memory being configured to change the RFID tag from a first state to a second state.

45. The method of claim 44, wherein the first state is a state in which the RFID tag will not transmit an RF signal.

27

46. The method of claim 44, wherein using an integrated circuit to compare the first data received through the RF antenna with the key is only performed if the state of the mechanical switch is ON.

47. The method of claim 44, wherein the state memory is non-volatile memory.

48. The method of claim 44, further including automatically returning to the OFF state.

49. The method of claim 44, further sending a response signal using the RF antenna if the second state is an ON state.

50. The method of claim 44, wherein the RFID tag is disposed within a passport, driver's license, financial card, military ID card, key, or keycard.

51. A method of changing a state of an RFID Tag, the method comprising:

receiving energy sufficient to power the RFID Tag through an RF antenna included in the RFID tag;

receiving first data through the RF antenna;

reading a key from a key memory;

using an integrated circuit to compare the first data received through the RF antenna with the key read from the key memory, the integrated circuit powered by the received energy; and

writing data to state memory responsive to the comparison, the data written to the state memory being configured to change the RFID tag from a first state to a second state, wherein the first state and the second state are alternative ON states.

52. The method of claim 51, wherein the state memory is non-volatile memory.

53. A method of changing a state of an RFID Tag, the method comprising:

receiving energy sufficient to power the RFID Tag through an RF antenna included in the RFID tag;

receiving first data through the RF antenna;

reading a key from a key memory;

using an integrated circuit to compare the first data received through the RF antenna with the key read from the key memory, the integrated circuit powered by the received energy;

writing data to state memory responsive to the comparison, the data written to the state memory being configured to change the RFID tag from a first state to a second state; and

28

providing an RF response, a content of data in the RF response being responsive to the comparison.

54. A method comprising:

receiving a first signal at an RFID Tag through an RF antenna included in the RFID tag;

reading a state from a state memory, the state memory being configured to alternatively store an OFF state, a first ON state and a second ON state; and

sending a response signal using the RF antenna if the state is the first ON state or the second ON state, the response signal being a response to the first signal, wherein contents of the response signal are responsive to whether the state is the first ON state or the second ON state.

55. The method of claim 54, wherein the RFID tag is disposed within a cellular phone.

56. The RFID tag of claim 54, wherein the RFID tag is disposed within a passport, driver's license, financial card, military ID card, key, or keycard.

57. A method comprising:

receiving a first signal at an RFID Tag through an RF antenna included in the RFID tag;

reading a state from a state memory, the state memory being configured to alternatively store an OFF state, a first ON state and a second ON state; and

sending a response signal using the RF antenna if the state is the first ON state or the second ON state, the response signal being a response to the first signal, wherein sending the response signal is responsive to a mechanical switch.

58. The RFID tag of claim 57, wherein the RFID tag is disposed within a cellular telephone.

59. The RFID tag of claim 57, wherein the RFID tag is disposed within a passport, driver's license, financial card, military ID card, key, or keycard.

60. A method comprising:

receiving a first signal at an RFID Tag through an RF antenna included in the RFID tag;

reading a state from a state memory, the state memory being configured to alternatively store an OFF state, a first ON state and a second ON state;

sending a response signal using the RF antenna if the state is the first ON state or the second ON state, the response signal being a response to the first signal; and

changing the state in the state memory responsive to an RF signal.

\* \* \* \* \*