



US008356251B2

(12) **United States Patent**
Strober

(10) **Patent No.:** **US 8,356,251 B2**
(45) **Date of Patent:** **Jan. 15, 2013**

(54) **PLAY CONTROL OF CONTENT ON A DISPLAY DEVICE**

(75) Inventor: **David Strober**, Rye, NY (US)

(73) Assignee: **Touchstream Technologies, Inc.**,
Valhalla, NY (US)

(*) Notice: Subject to any disclaimer, the term of this patent is extended or adjusted under 35 U.S.C. 154(b) by 4 days.

(21) Appl. No.: **13/245,001**

(22) Filed: **Sep. 26, 2011**

(65) **Prior Publication Data**
US 2012/0272148 A1 Oct. 25, 2012

Related U.S. Application Data

(63) Continuation of application No. 13/157,821, filed on Jun. 10, 2011.

(60) Provisional application No. 61/477,998, filed on Apr. 21, 2011.

(51) **Int. Cl.**
G06F 3/00 (2006.01)

(52) **U.S. Cl.** **715/740; 715/716; 715/734; 715/738; 715/751; 715/764; 715/835**

(58) **Field of Classification Search** **715/716, 715/738, 734, 740, 751, 764, 835**
See application file for complete search history.

(56) **References Cited**

U.S. PATENT DOCUMENTS

7,058,356 B2 6/2006 Slotznick
7,330,875 B1 * 2/2008 Parasnis et al. 709/204
7,424,718 B2 * 9/2008 Dutton 719/318
7,433,922 B2 * 10/2008 Engstrom 709/205

7,440,972 B2 * 10/2008 Oetzel 386/252
7,453,454 B2 * 11/2008 Allen et al. 345/418
7,769,827 B2 * 8/2010 Girouard et al. 709/219
7,774,708 B2 * 8/2010 Bell et al. 715/738
7,814,144 B2 * 10/2010 Koyama et al. 709/203
7,835,505 B2 11/2010 Toyama et al.

(Continued)

FOREIGN PATENT DOCUMENTS

CN 101534449 9/2009

(Continued)

OTHER PUBLICATIONS

Ask Search Internet Search, session identifier random.*

(Continued)

Primary Examiner — Boris Pesin

Assistant Examiner — John Heffington

(74) *Attorney, Agent, or Firm* — Fish & Richardson P.C.

(57) **ABSTRACT**

A system for presenting and controlling content on a display device includes a network, a server system coupled to the network and comprising one or more servers, a display device coupled to the network and having a display, and a personal computing device operable to transmit a first message according to a specified format over the network to the server system. The server system stores an association between the personal computing device and the display device. The first message identifies user-selected content and a media player to play the content. The server system is operable, in response to receiving the first message from the personal computing device, to provide to the display device a second message identifying the user-selected content and the media player to play the content. In response to receiving the second message, the display device is operable to obtain a first media player needed to play the content, to load the media player and to present the content on the display.

26 Claims, 9 Drawing Sheets

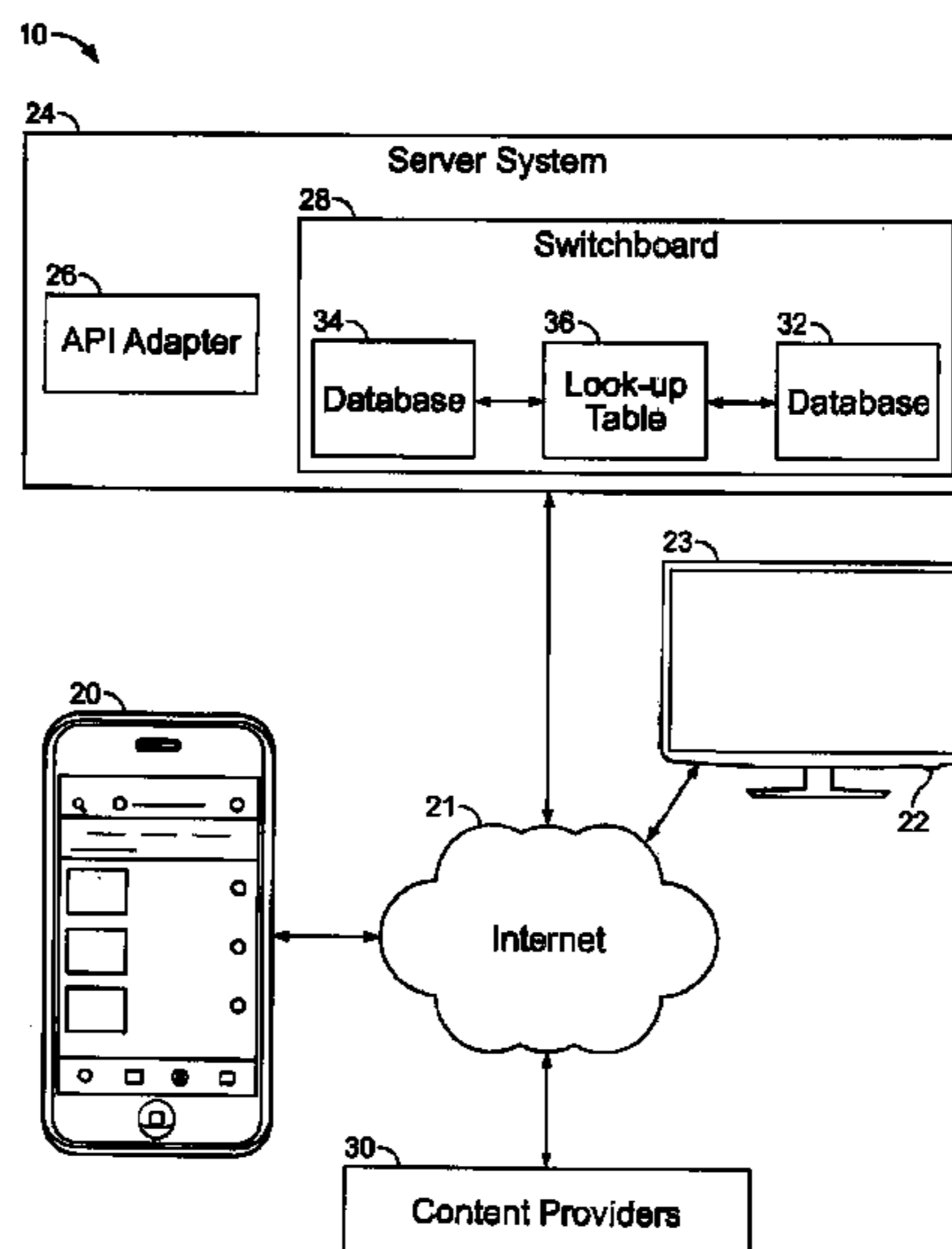

U.S. PATENT DOCUMENTS

| | | | | |
|--------------|------|---------|----------------------------|-------------|
| 7,849,485 | B2 | 12/2010 | Paik et al. | |
| 8,086,679 | B2 * | 12/2011 | Nobori et al. | 709/206 |
| 8,171,507 | B2 * | 5/2012 | Hironaka et al. | 725/12 |
| 2002/0075332 | A1 * | 6/2002 | Geilfuss et al. | 345/859 |
| 2002/0120666 | A1 * | 8/2002 | Landsman et al. | 709/200 |
| 2002/0129102 | A1 * | 9/2002 | Landsman et al. | 709/203 |
| 2002/0133518 | A1 * | 9/2002 | Landsman et al. | 707/513 |
| 2002/0198778 | A1 * | 12/2002 | Landsman et al. | 705/14 |
| 2003/0004804 | A1 * | 1/2003 | Landsman et al. | 705/14 |
| 2003/0005000 | A1 * | 1/2003 | Landsman et al. | 707/513 |
| 2003/0018885 | A1 * | 1/2003 | Landsman et al. | 713/2 |
| 2003/0023488 | A1 * | 1/2003 | Landsman et al. | 705/14 |
| 2003/0028565 | A1 * | 2/2003 | Landsman et al. | 707/513 |
| 2003/0142127 | A1 * | 7/2003 | Markel | 345/738 |
| 2003/0182663 | A1 * | 9/2003 | Gudorf et al. | 725/110 |
| 2003/0193520 | A1 * | 10/2003 | Oetzel | 345/723 |
| 2004/0008972 | A1 * | 1/2004 | Haken | 386/83 |
| 2004/0088728 | A1 * | 5/2004 | Shimizu | 725/89 |
| 2004/0268224 | A1 * | 12/2004 | Balkus et al. | 715/500.1 |
| 2004/0268451 | A1 * | 12/2004 | Robbin et al. | 999/999.999 |
| 2005/0034151 | A1 | 2/2005 | Abramson | |
| 2005/0144305 | A1 * | 6/2005 | Fegan et al. | 709/231 |
| 2006/0083194 | A1 | 4/2006 | Dhrimaj et al. | |
| 2006/0098624 | A1 * | 5/2006 | Morgan et al. | 370/352 |
| 2006/0101098 | A1 * | 5/2006 | Morgan et al. | 707/204 |
| 2006/0200832 | A1 * | 9/2006 | Dutton | 719/318 |
| 2006/0203758 | A1 | 9/2006 | Tee et al. | |
| 2006/0263038 | A1 * | 11/2006 | Gilley | 386/52 |
| 2006/0265657 | A1 * | 11/2006 | Gilley | 715/730 |
| 2007/0050054 | A1 * | 3/2007 | Sambandam Guruparan et al. | 700/65 |
| 2007/0055986 | A1 * | 3/2007 | Gilley et al. | 725/34 |
| 2007/0083540 | A1 * | 4/2007 | Gundla et al. | 707/101 |
| 2007/0094408 | A1 * | 4/2007 | Gundla et al. | 709/231 |
| 2007/0112785 | A1 * | 5/2007 | Murphy et al. | 707/10 |
| 2007/0202923 | A1 | 8/2007 | Jung et al. | |
| 2007/0288715 | A1 | 12/2007 | Boswell et al. | |
| 2008/0008439 | A1 * | 1/2008 | Liu et al. | 386/46 |
| 2008/0028037 | A1 * | 1/2008 | Moyer et al. | 709/217 |
| 2008/0034394 | A1 * | 2/2008 | Jacobs et al. | 725/98 |
| 2008/0077526 | A1 | 3/2008 | Arumugam | |
| 2008/0126943 | A1 * | 5/2008 | Parasnis et al. | 715/730 |
| 2008/0140849 | A1 * | 6/2008 | Collazo | 709/229 |
| 2008/0155600 | A1 | 6/2008 | Klappert et al. | |
| 2008/0187279 | A1 * | 8/2008 | Gilley et al. | 386/52 |
| 2008/0189617 | A1 * | 8/2008 | Covell et al. | 715/738 |
| 2008/0267369 | A1 * | 10/2008 | Parlamas et al. | 379/93.01 |
| 2008/0270881 | A1 * | 10/2008 | Meyer et al. | 715/202 |
| 2008/0301737 | A1 * | 12/2008 | Hjelmeland Almas et al. | 725/61 |
| 2009/0049373 | A1 * | 2/2009 | Sharma et al. | 715/234 |
| 2009/0094331 | A1 * | 4/2009 | Nobori et al. | 709/205 |
| 2009/0164641 | A1 * | 6/2009 | Rogers et al. | 709/227 |
| 2009/0228919 | A1 | 9/2009 | Zott et al. | |
| 2009/0254827 | A1 * | 10/2009 | Gonze et al. | 715/716 |
| 2009/0259944 | A1 * | 10/2009 | Wu | 715/738 |
| 2009/0282470 | A1 * | 11/2009 | Yang et al. | 726/12 |
| 2010/0027974 | A1 | 2/2010 | Ansari | |
| 2010/0094728 | A1 * | 4/2010 | Denning et al. | 705/27 |
| 2010/0137028 | A1 | 6/2010 | Farris et al. | |
| 2010/0138746 | A1 * | 6/2010 | Zarom | 715/720 |
| 2010/0174993 | A1 * | 7/2010 | Pennington et al. | 715/738 |
| 2010/0198860 | A1 * | 8/2010 | Burnett et al. | 707/769 |
| 2010/0205628 | A1 | 8/2010 | Davis et al. | |
| 2010/0265939 | A1 * | 10/2010 | Parlamas et al. | 370/352 |
| 2010/0281042 | A1 * | 11/2010 | Windes et al. | 707/756 |
| 2010/0283586 | A1 * | 11/2010 | Ikeda et al. | 340/10.42 |
| 2010/0313135 | A1 * | 12/2010 | Johnson et al. | 715/738 |
| 2010/0325552 | A1 * | 12/2010 | Sloo et al. | 715/738 |
| 2011/0007901 | A1 * | 1/2011 | Ikeda et al. | 380/270 |
| 2011/0014972 | A1 * | 1/2011 | Herrmann et al. | 463/25 |
| 2011/0030020 | A1 | 2/2011 | Halttunen | |
| 2011/0035692 | A1 * | 2/2011 | Sandone et al. | 715/769 |
| 2011/0060998 | A1 * | 3/2011 | Schwartz et al. | 715/738 |
| 2011/0090898 | A1 * | 4/2011 | Patel et al. | 370/352 |
| 2011/0107227 | A1 * | 5/2011 | Rempell et al. | 715/738 |
| 2011/0125594 | A1 * | 5/2011 | Brown et al. | 705/14.73 |
| 2011/0138354 | A1 * | 6/2011 | Hertenstein et al. | 717/115 |

| | | | | |
|--------------|------|---------|-------------------|-----------|
| 2011/0156879 | A1 * | 6/2011 | Matsushita et al. | 340/10.1 |
| 2011/0161396 | A1 * | 6/2011 | Filbrich et al. | 709/203 |
| 2011/0214148 | A1 * | 9/2011 | Gossweiler et al. | 725/46 |
| 2011/0228768 | A1 * | 9/2011 | Gelter et al. | 370/389 |
| 2011/0231265 | A1 * | 9/2011 | Brown et al. | 705/14.73 |
| 2011/0231565 | A1 * | 9/2011 | Gelter et al. | 709/231 |
| 2011/0231566 | A1 * | 9/2011 | Gelter et al. | 709/231 |
| 2011/0289419 | A1 * | 11/2011 | Yu et al. | 715/738 |
| 2011/0296454 | A1 * | 12/2011 | Xiong et al. | 725/30 |
| 2011/0296465 | A1 | 12/2011 | Krishnan et al. | |
| 2012/0072846 | A1 * | 3/2012 | Curtis | 715/738 |
| 2012/0110464 | A1 * | 5/2012 | Chen et al. | 715/738 |
| 2012/0166560 | A1 * | 6/2012 | Nobori et al. | 709/206 |

FOREIGN PATENT DOCUMENTS

| | | |
|----|-----------|---------|
| CN | 101577650 | 11/2009 |
| CN | 101778198 | 7/2010 |
| CN | 101815073 | 8/2010 |

OTHER PUBLICATIONS

Webopedia computer dictionary, session cookie.*
 Webopedia computer dictionary, web identifier.*
 Webopedia computer dictionary, user session.*
 www.vbulletin.com, Best way to generate Random, Unique ID's.*
 www.vbulletin.com, Best way to generate Random, Unique ID's, Internet Archive Wayback Machine, Jan. 16, 2009.*
 webopedia-com—session-identifier—Nov. 19, 2011.*
 www.vbulletin.com—best-way-to-generate-random-unique-session-ids—Nov. 19, 2011.*
 www.vbulletin.com—best-way-to-generate-random-unique-session-ids-wayback-archive—Nov. 19, 2011.*
 ask—search—q=mobile+device+server+display+device&q.s.*
 Ask—Search—q=session+identifier+random&qsrc=0&o=0&I—Nov. 19, 2011.*
 webopedia-com—session_cookie—Nov. 19, 2011.*
 webopedia-com—user_session—Nov. 19, 2011.*
 Ask Search Internet Search, session identifier random, printed on Nov. 19, 2011.
 Webopedia computer dictionary, session cookie, printed on Nov. 19, 2011.
 Webopedia computer dictionary, web identifier, printed on Nov. 19, 2011.
 Webopedia computer dictionary, user session, printed on Nov. 19, 2011.
 www.vbulletin.com, Best way to generate Random, Unique ID's, printed on Nov. 19, 2011.
 Officials communication from the USPTO in U.S. Appl. No. 13/245,001, dated Dec. 8, 2011.
 U.S. Appl. No. 13,245,001, filed Sep. 26, 2011.
 Hachman, M., "Snapstick's Media Streaming App/Box: Hands on," www.pcmag.com/article2/0,2817,2375455,00.asp, 2 pages, (Jan. 8, 2011).
 Dolcourt, J., CES: Snapstick takes on Apple TV, Google TV, http://news.cnet.com/8301-17938_105-20025100-1.html, 3 pages, (Dec. 9, 2010).
 Shaivitz, M., "The Web to Your TV, With a Flick of a Wrist? Slapstick Says Yes," <http://techcocktail.com/the-web-to-our-tv-with-a-flick-of-a-wrist-slapstick-says-yes-2010-12>, 2 pages, (Dec. 10, 2010).
 Snapstick—Home, "Snapstick," <http://www.snapstick.com/>, 2 pages, printed on Mar. 2, 2011.
 Paul, I., Hands on: YouTube Leanback, PCWORLD, http://www.pcworld.com/article/200769/hands_on_youtube_leanback.html, 3 pages, (Jul. 9, 2010).
 Using AirPlay, Article HT4437, <http://support.apple.com/kb/HT4437>, 3 pages, (Apr. 18, 2011).
 Cheng, J., "Stream AirPlay video to regular TV? Apple might make it happen," <http://arstechnica.com/apple/news/2011/03/stream-air-play-video-to-a-regular-tv-apple-migh> . . . , 1 page, printed on Jun. 7, 2011.
 "Using the Play To Feature to stream media," <http://windows.microsoft.com/en-US/windows7/using-the-play-to-feature-to-stream-media>, 3 pages, printed on Jun. 7, 2011.

“YouTube—Leanback,” <http://www.youtube.com/t/leanback>, 1 page, printed on Jun. 7, 2011.

“Yahoo!7 TV Guide for iPhone, iPod touch and iPad on the iTunes App Store,” <http://itunes.apple.com/au/app/yahoo-7-tv-guide/id42471992?mt=8>, 2 pages, printed on Jun. 7, 2011.

Hu, C., et al., “Mobile Media Content Sharing in UPnP-Based Home Network Environment,” *Journal of Information Science and Engineering* 24, 1753-1769. (2008).

Fallahkhair, S., et al., “Dual Device User interface Design for Ubiquitous Language Learning: Mobile Phone and Interactive Television (iTV),” *Proceedings of the 2005 IEEE Int’l Workshop on Wireless and Mobile Technologies in Education*, 8 pages, 2005.

* cited by examiner

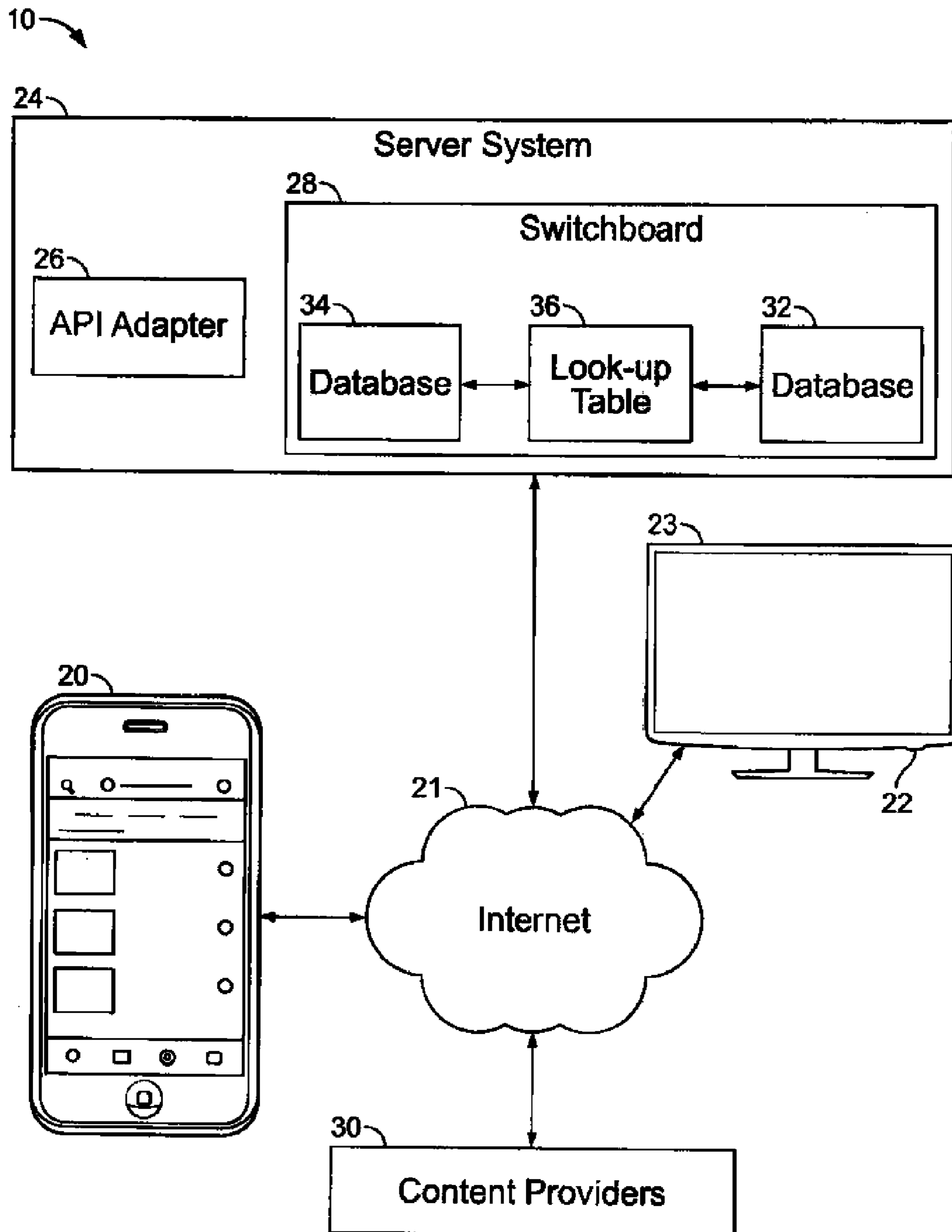

FIG. 1

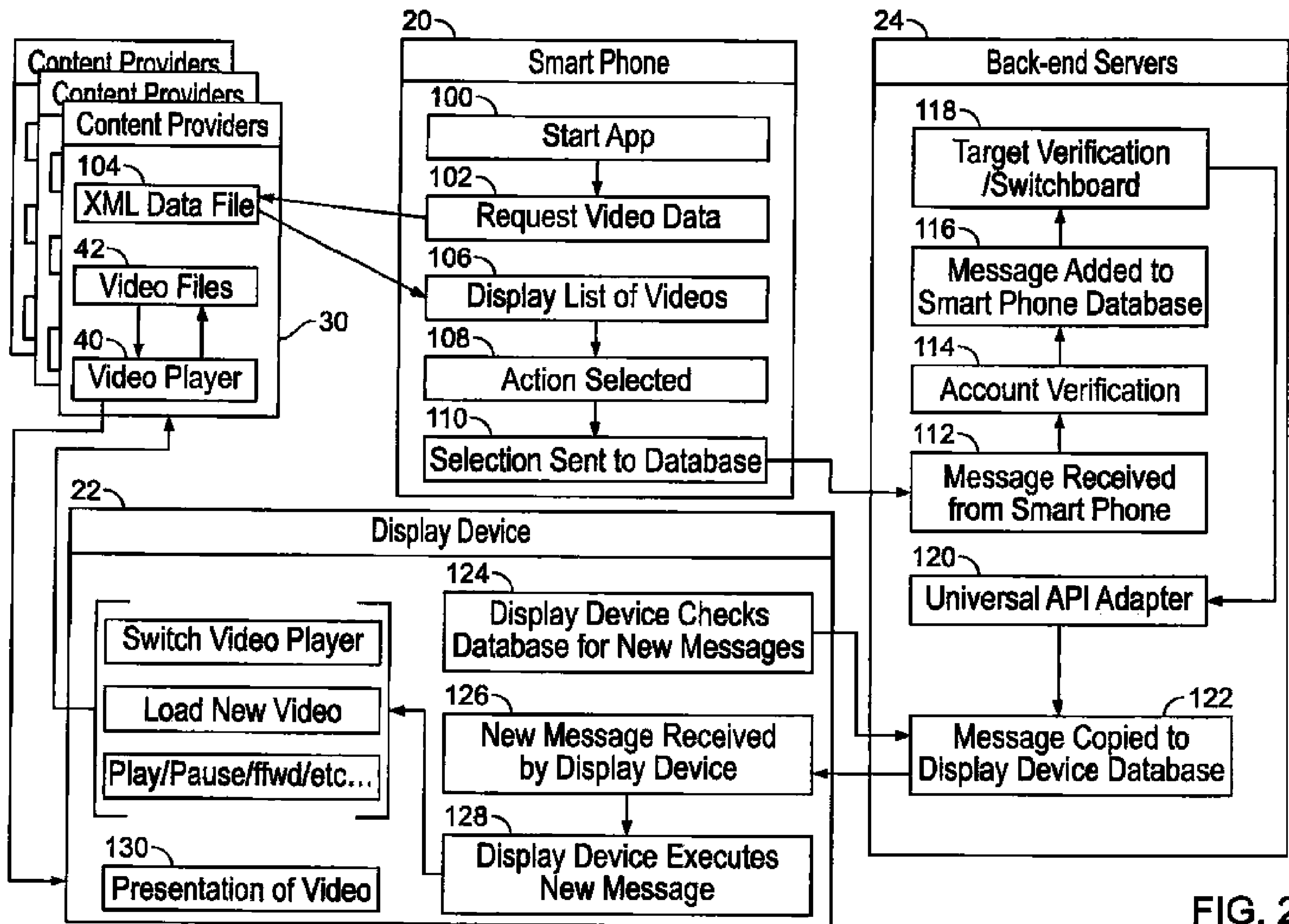

FIG. 2

| Transmission Code | | | | |
|-------------------|----------|---------------|---------|------|
| UserID | TargetID | MediaPlayerID | Command | Data |

FIG. 3

| Single Connection Look-up Table | |
|---------------------------------|-------------------|
| Display Device | User - Smartphone |
| 2 | A |
| 1 | C |
| 3 | D |
| 4 | B |

FIG. 4

26

| Universal API Adapter | | |
|-----------------------|---------------|-------------------------|
| Universal Command | MediaPlayerID | Specific Player Command |
| New Video | YouTube | yt_loadVideo |
| | Ted.com | getVideo |
| | Vimeo | loadNewVideo |
| Pause | YouTube | yt_pauseVideo |
| | Ted.com | pauseVideo |
| | Vimeo | pause |

FIG. 5

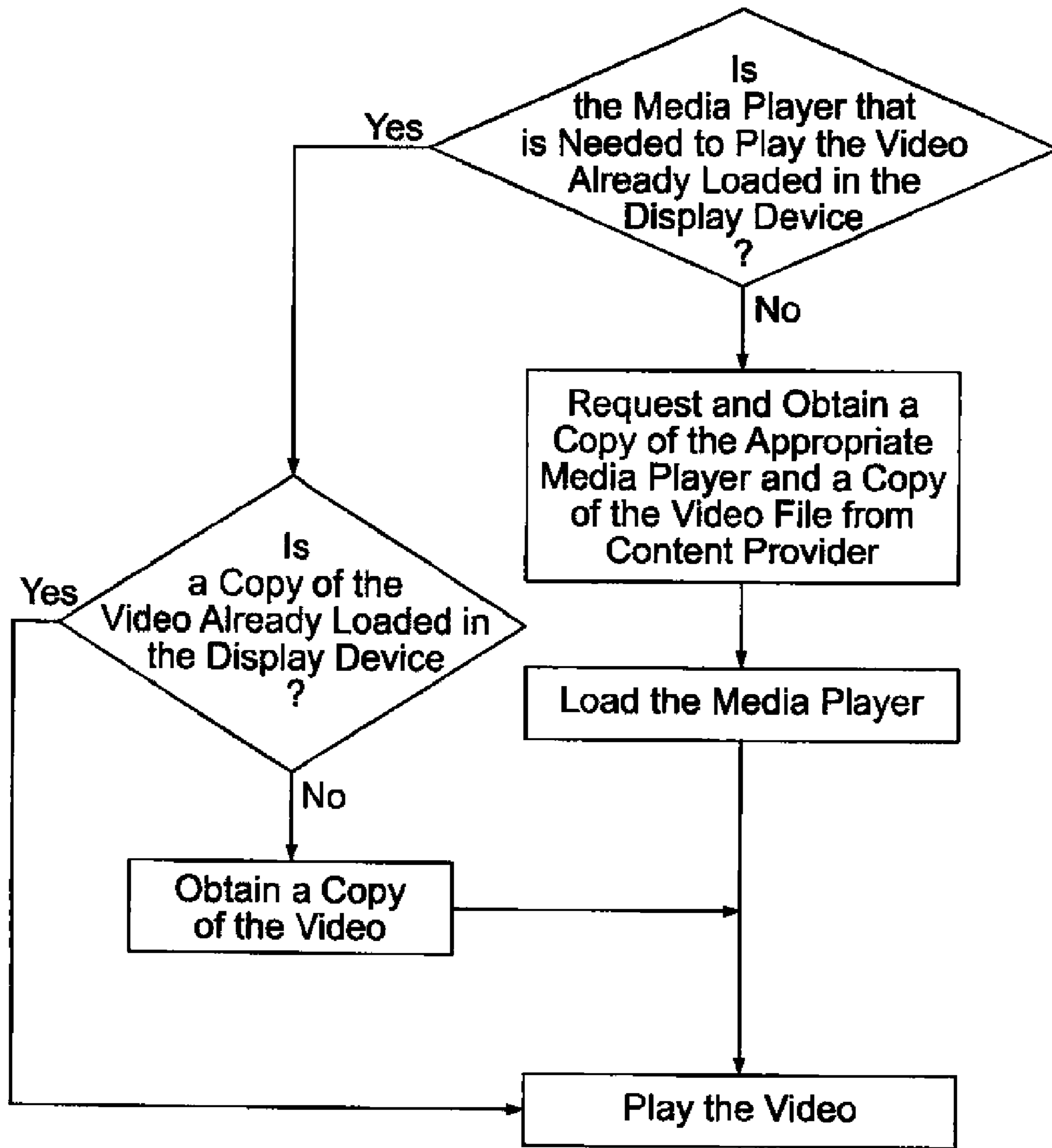

FIG. 6

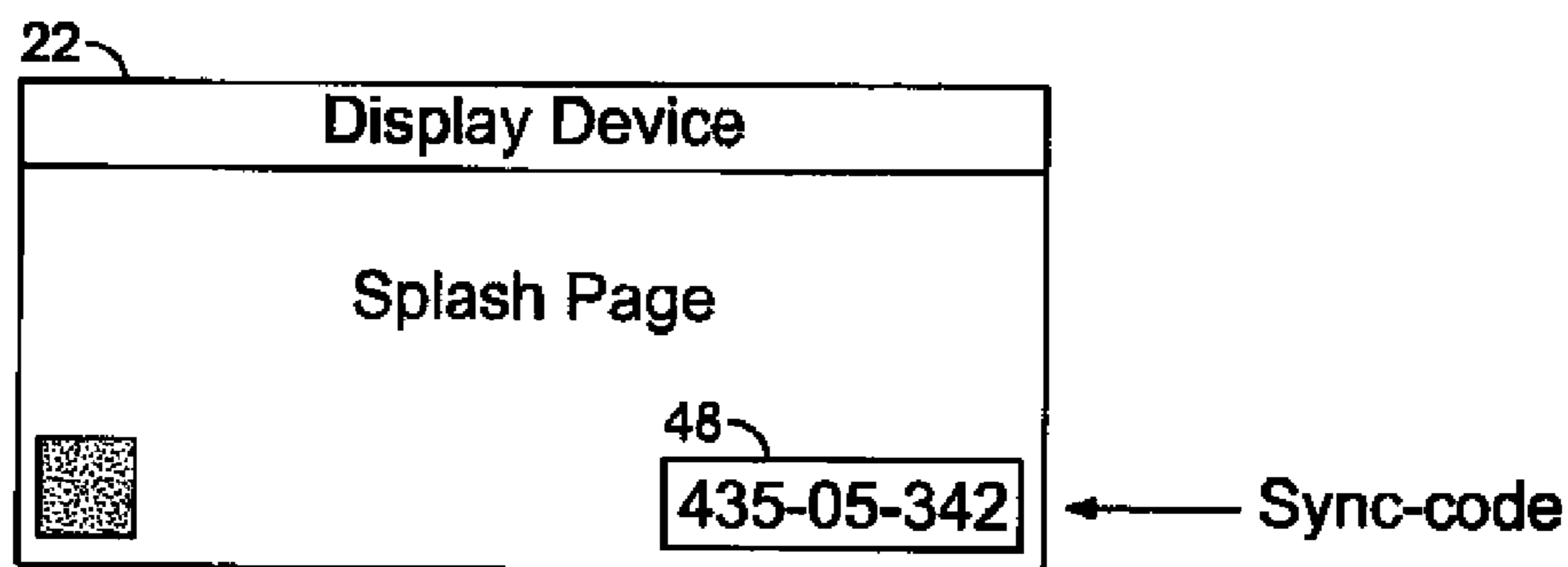

FIG. 7A

| Sync-code Look-up Table | | |
|-------------------------|-------------|------------|
| IP Address | Cookie | Sync-code |
| 169.343.231.234 | erjg988dhuj | 435-05-342 |

FIG. 7B

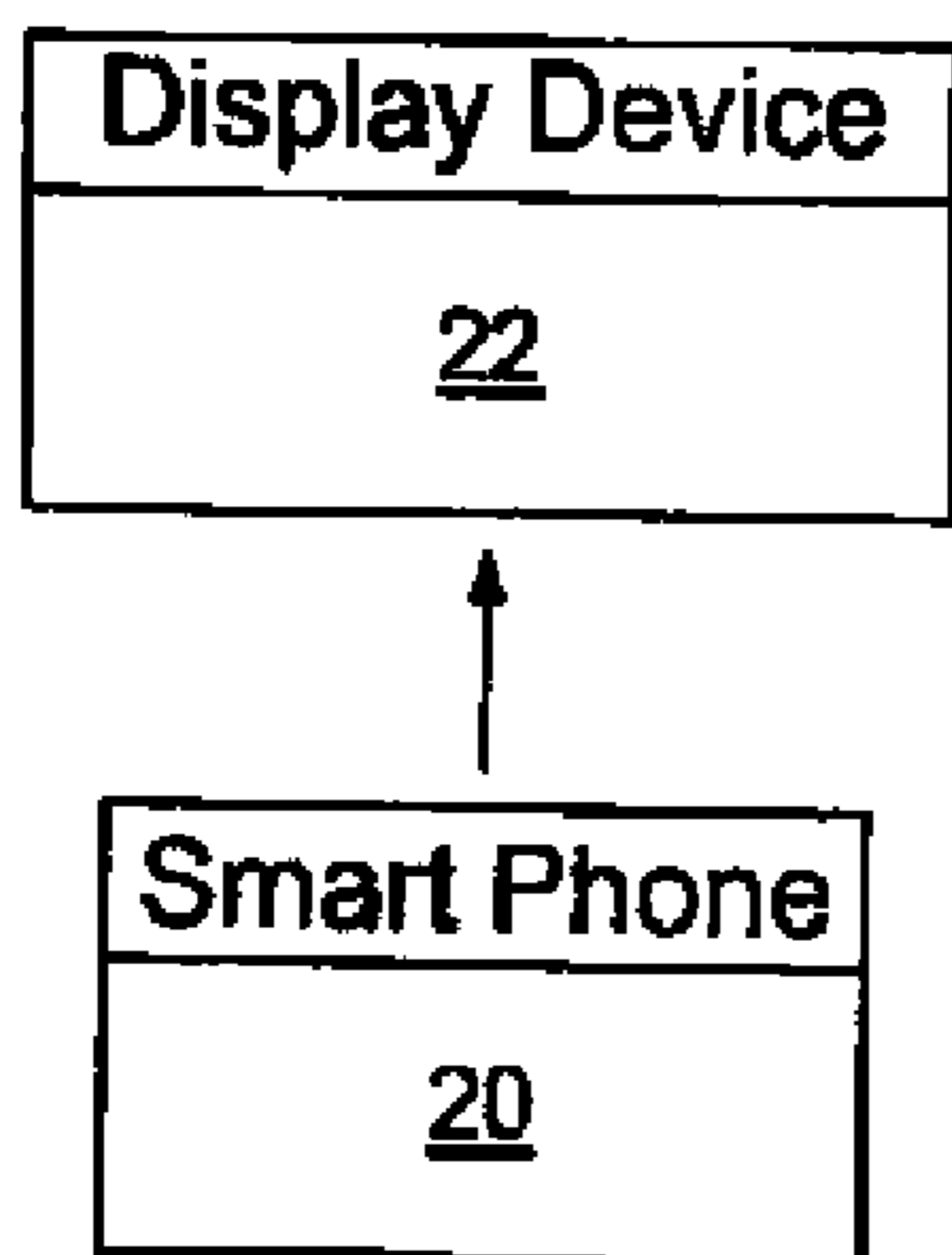

FIG. 8

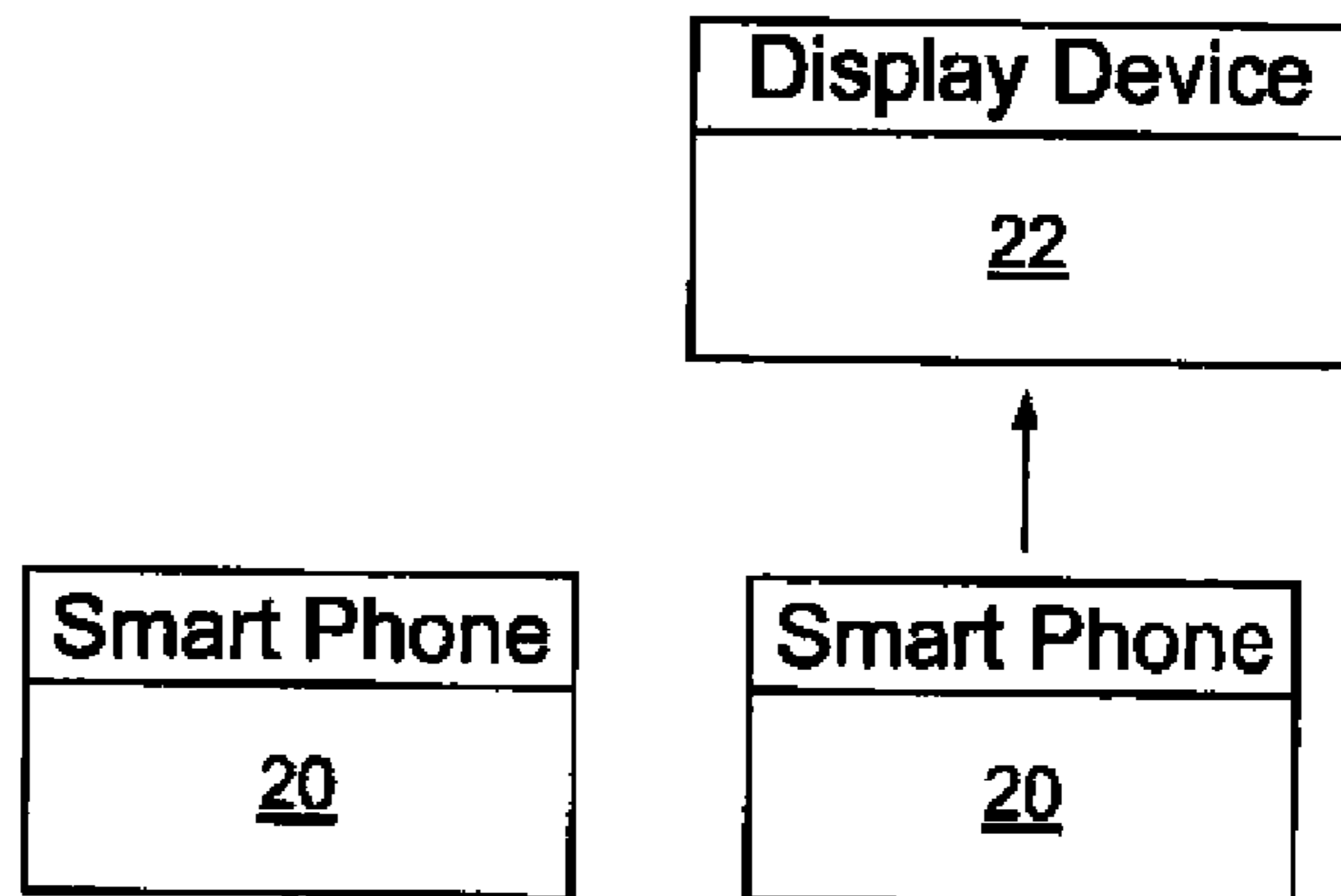

FIG. 9

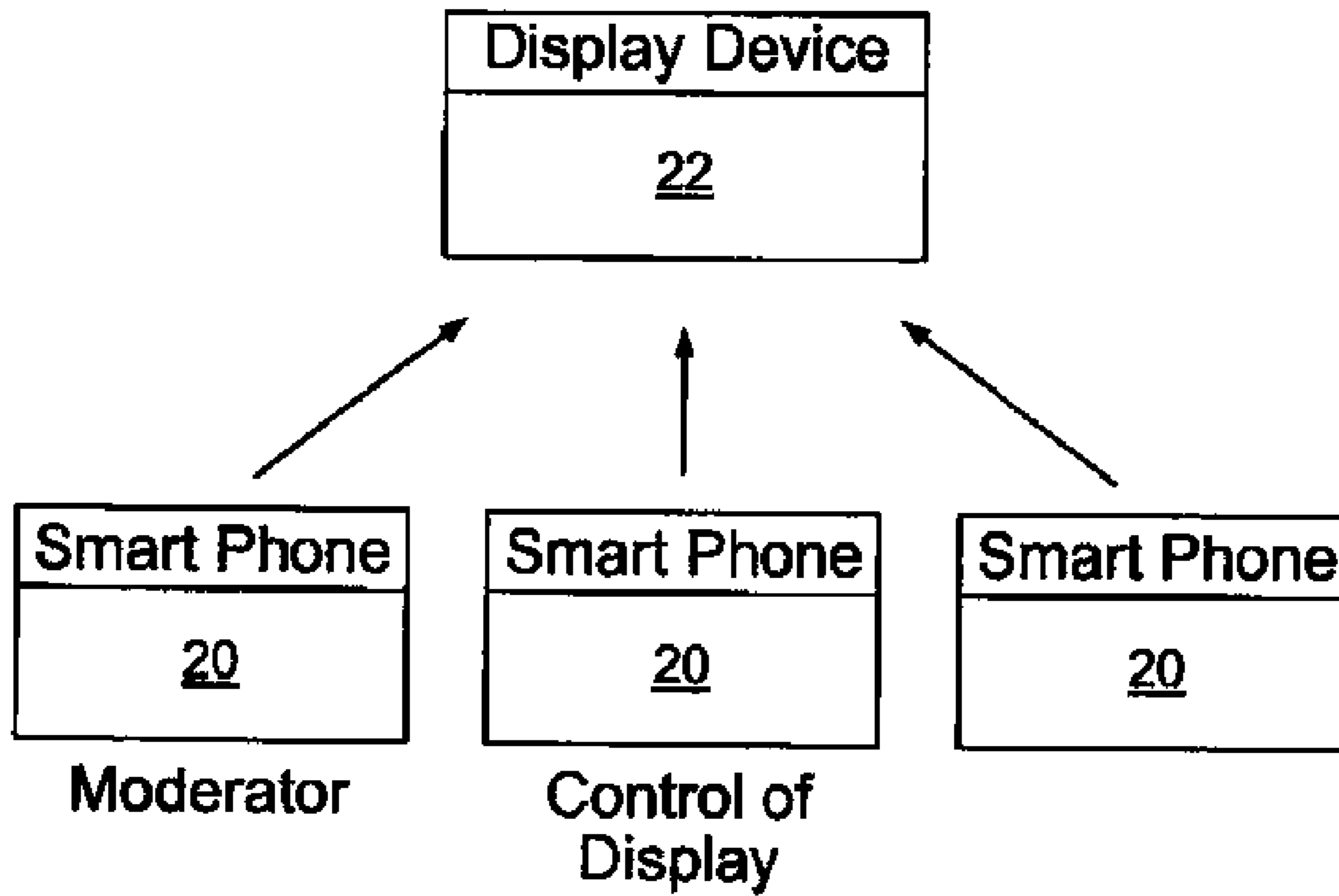

FIG. 10

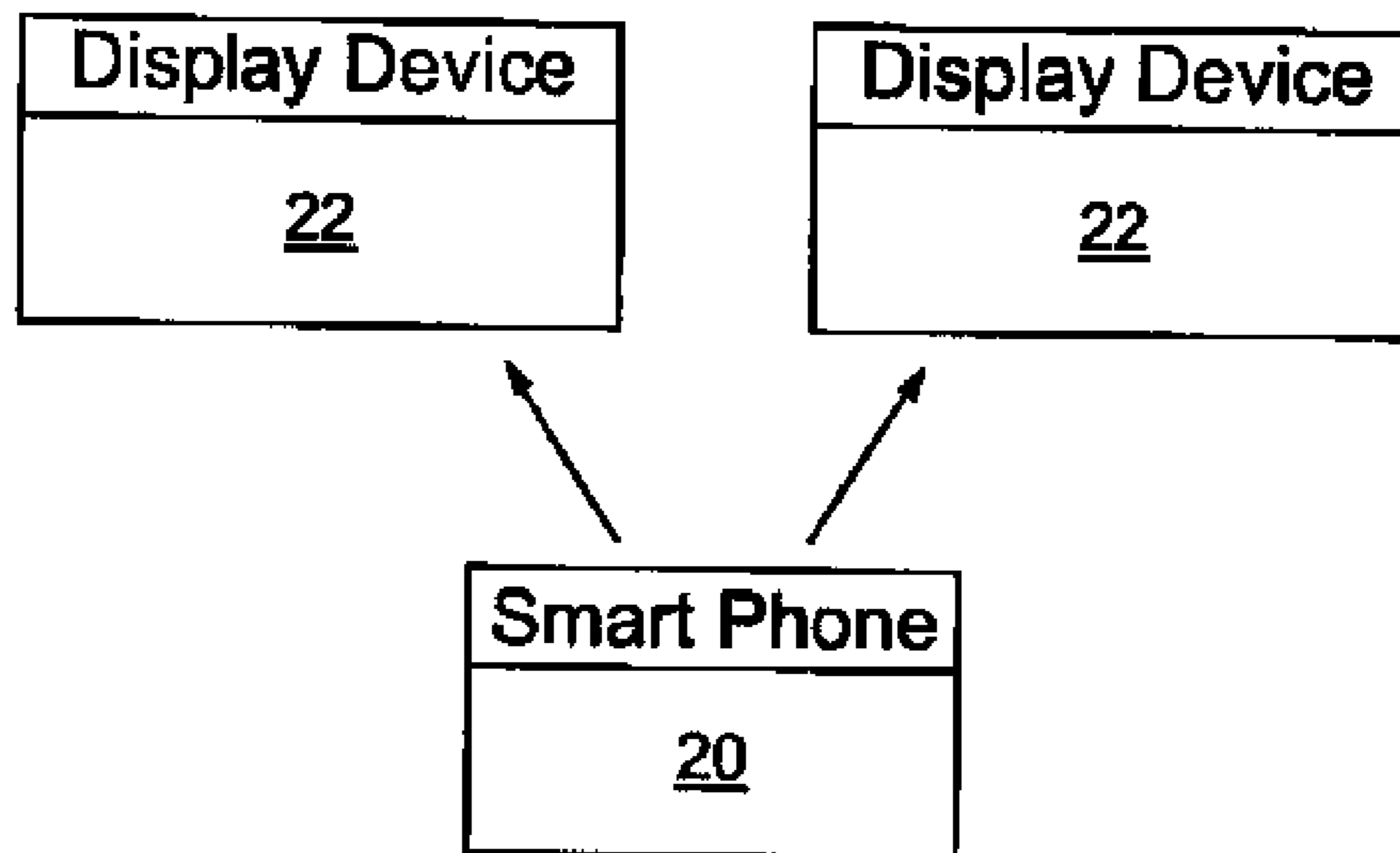

FIG. 11

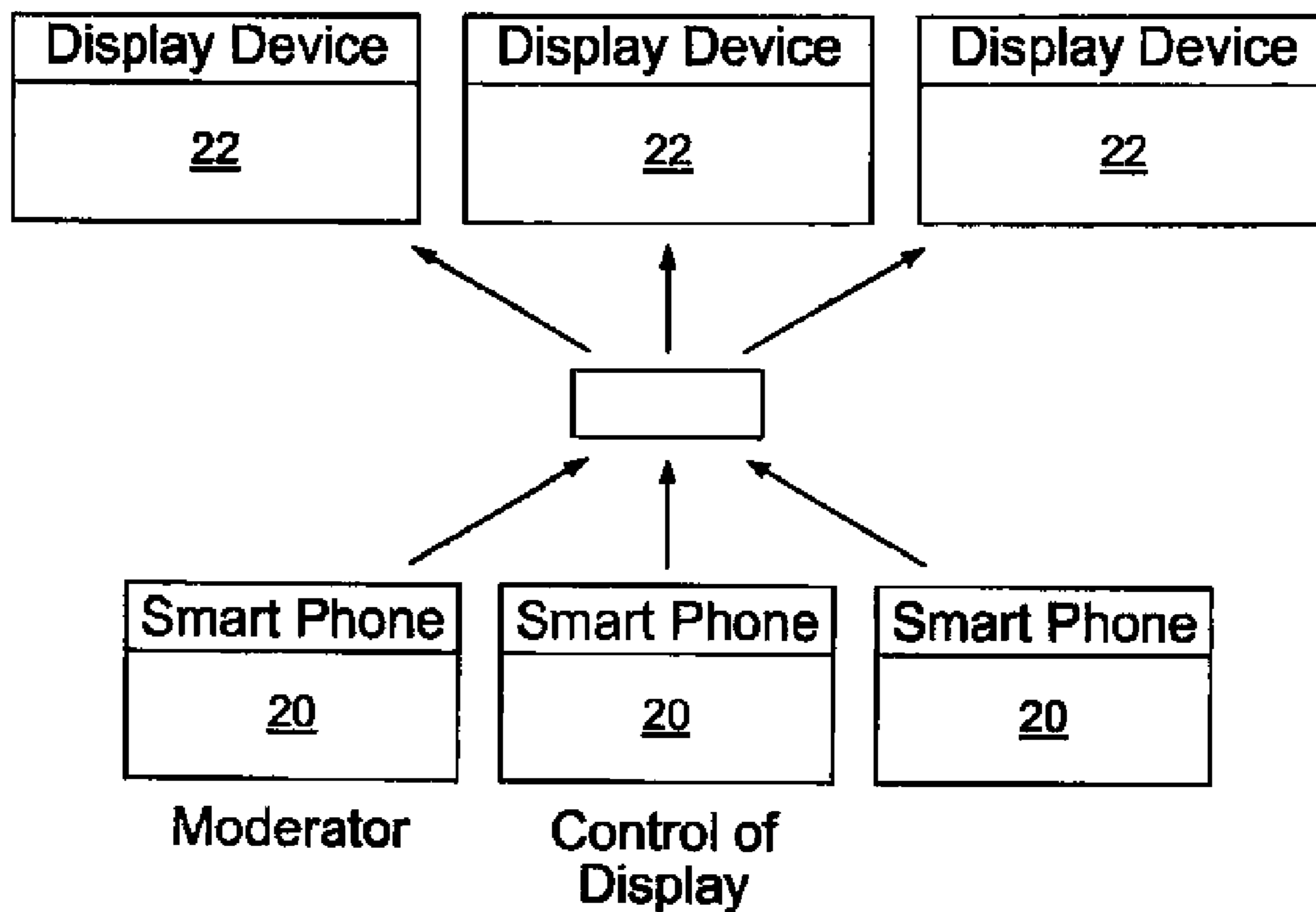

FIG. 12

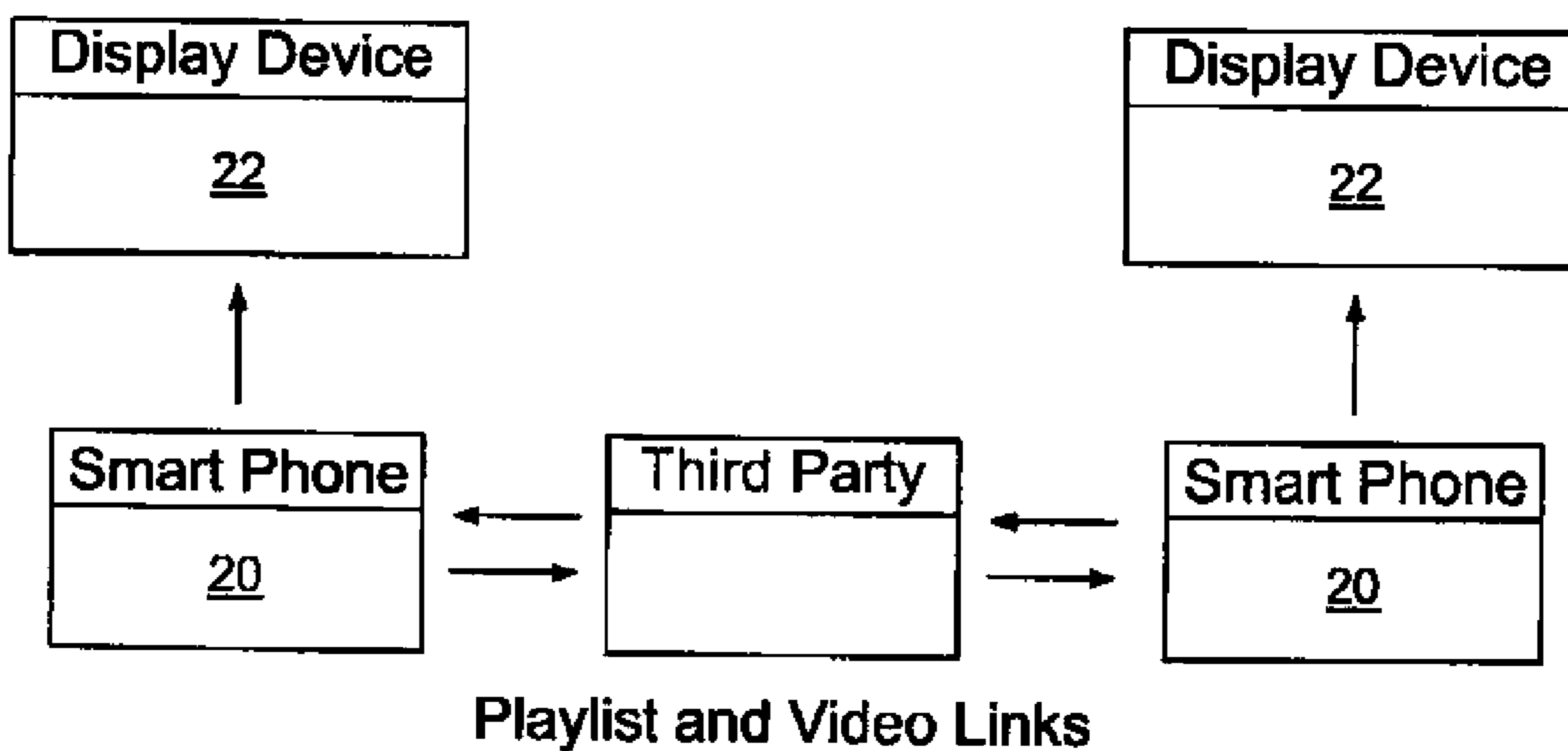

FIG. 13

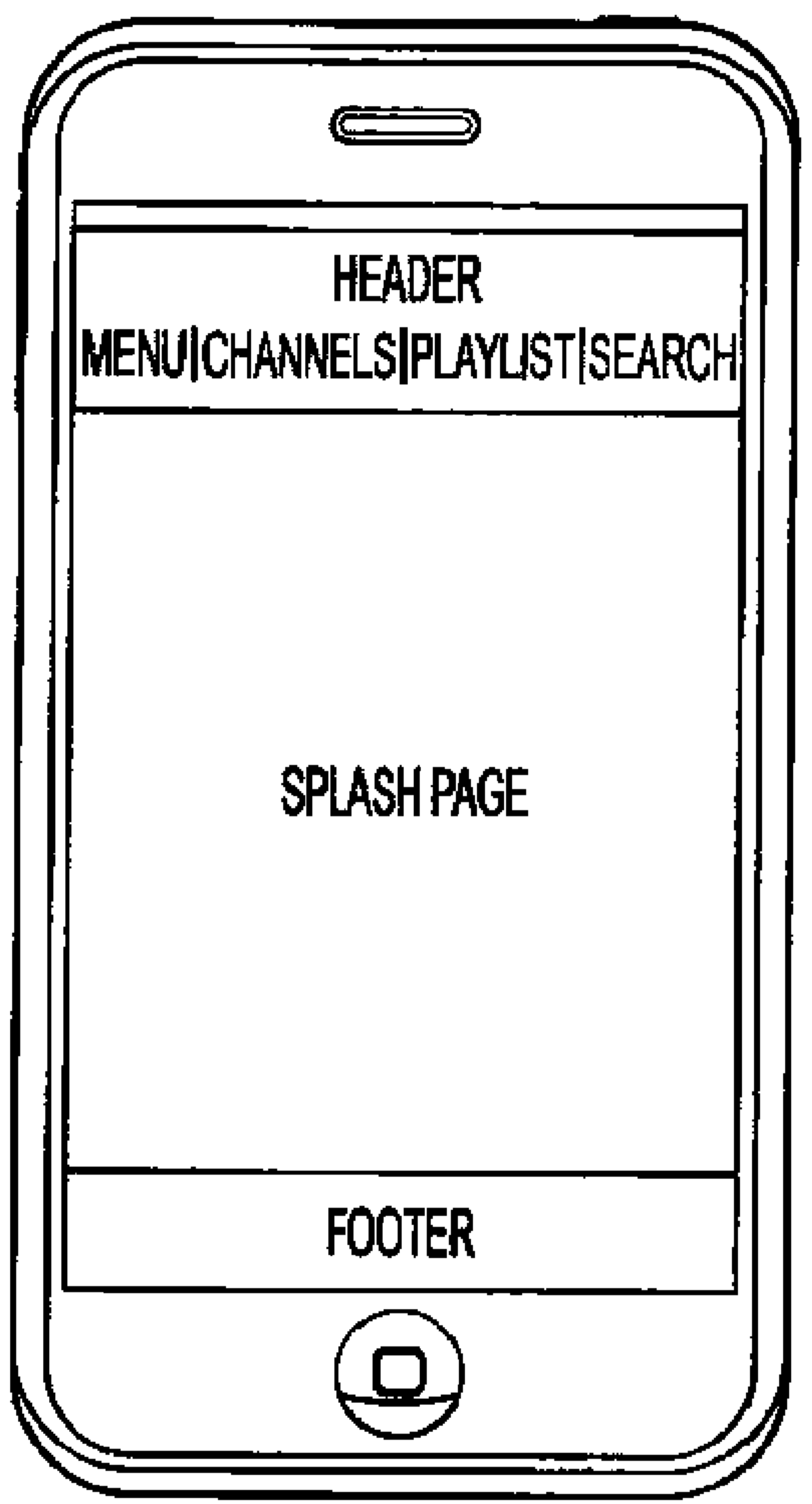

FIG. 14A

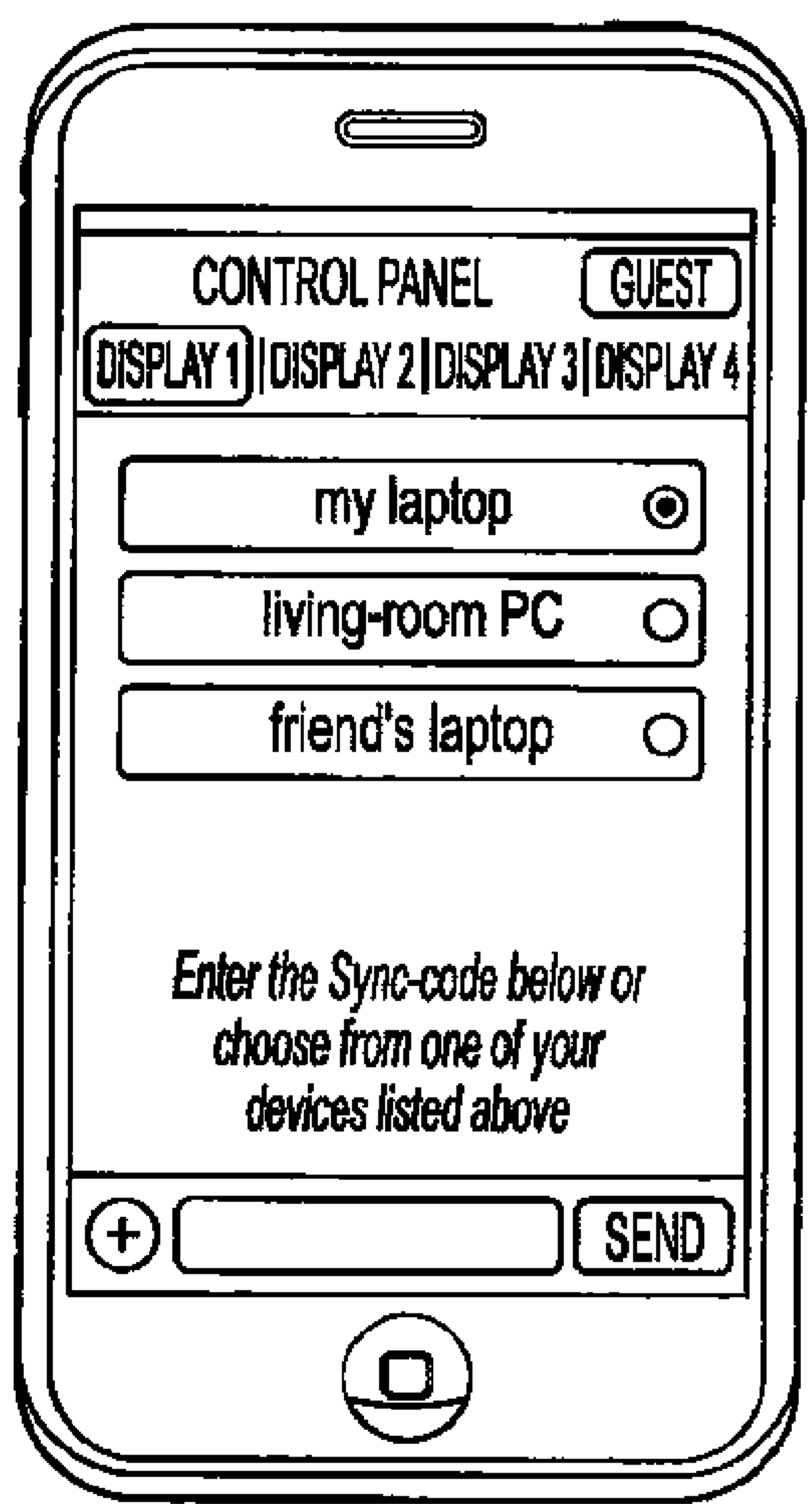

FIG. 14B

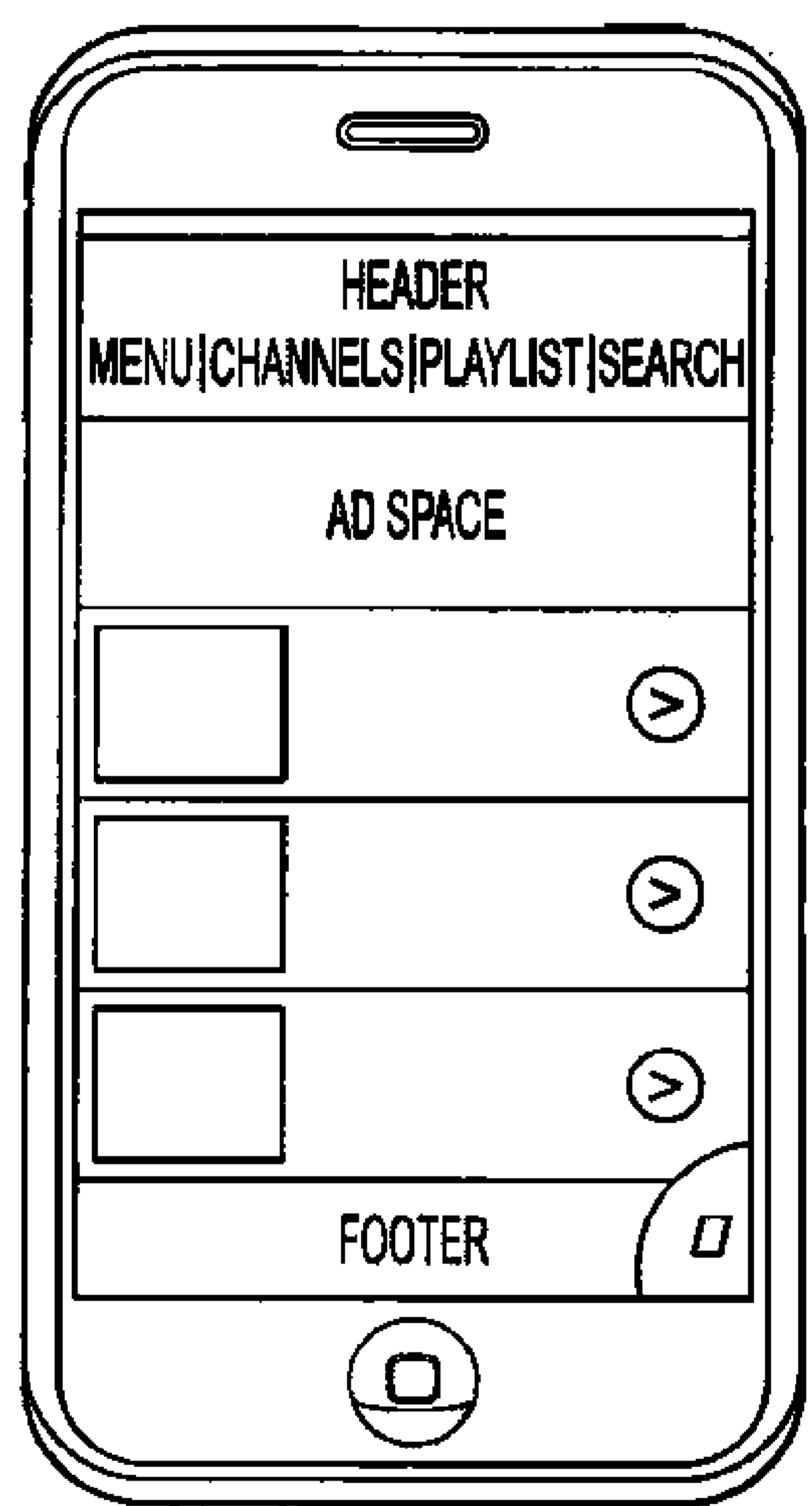

FIG. 14C

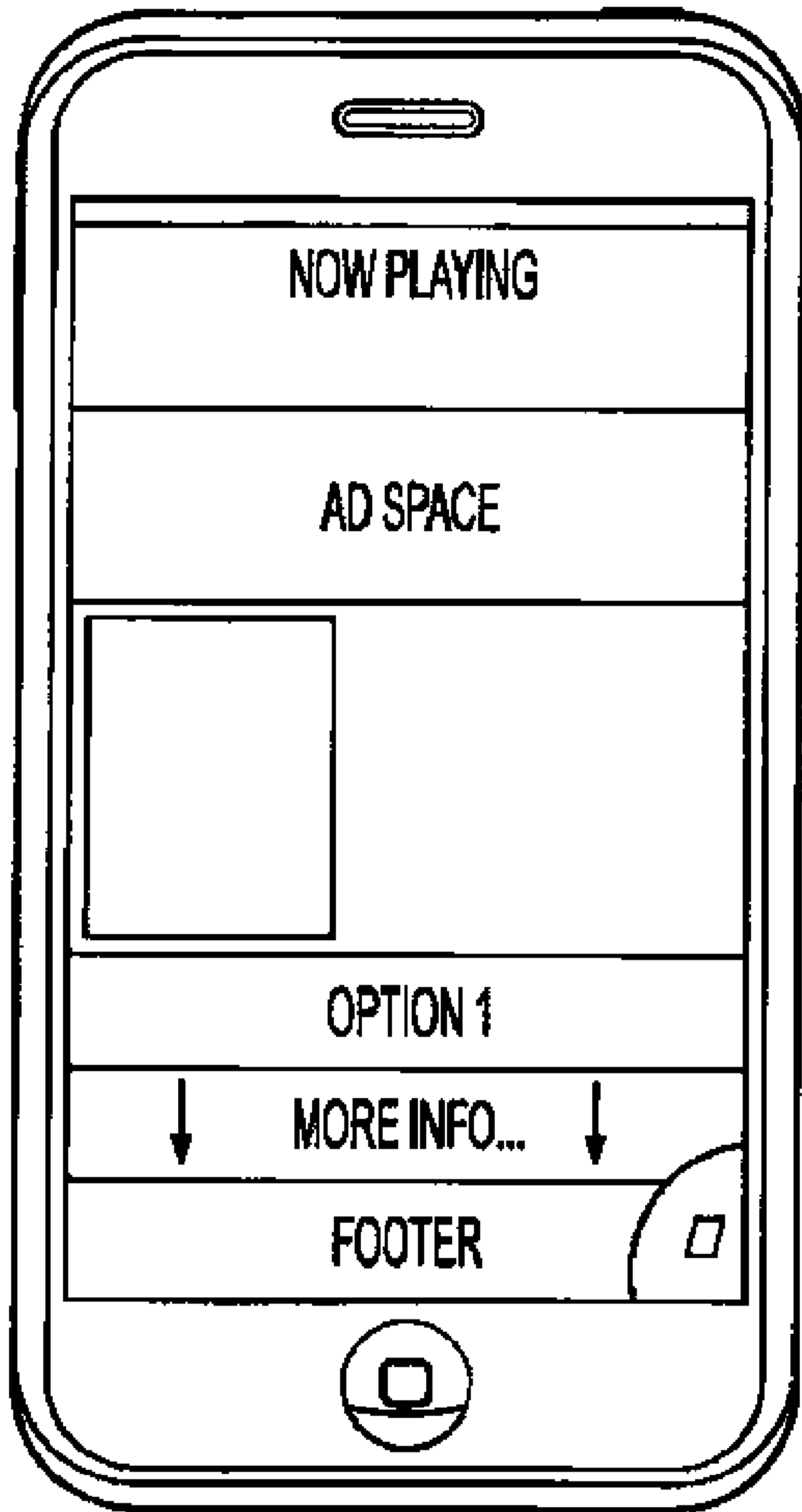

FIG. 14D

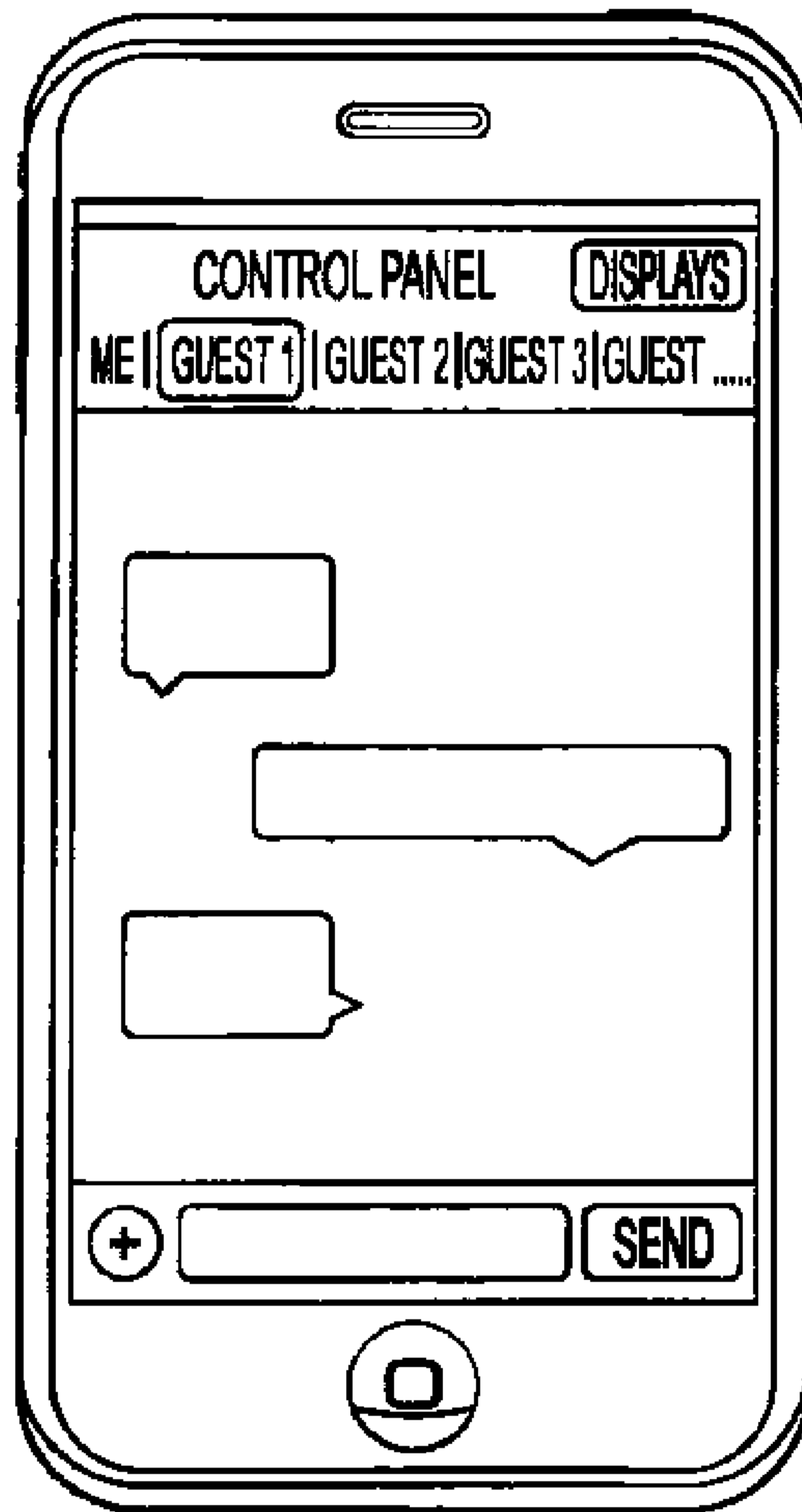

FIG. 14E

| Group Connection Look-up Table | | |
|--------------------------------|-------|-------------------------------------|
| Display Device | Group | User - Smartphone |
| 2 | X | A [*] , C [*] , D |
| 1,3 | Y | B ^{**} , E |

^{*} = Group Moderator,
^{**} = Control of Display Device

FIG. 15

PLAY CONTROL OF CONTENT ON A DISPLAY DEVICE

CROSS-REFERENCE TO RELATED APPLICATION(S)

This application is a continuation of U.S. application Ser. No. 13/157,821, filed on Jun. 10, 2011, which in turn claims the benefit of priority of U.S. Provisional Patent Application No. 61/477,998, filed on Apr. 21, 2011.

BACKGROUND

This disclosure relates to play control of content on a display device. Such display devices include, for example, television displays used by consumers in their home for viewing videos and other media that are either provided from the Web or previously stored. In particular, the disclosure relates to the creation, storage, manipulation and access of media playlists used in conjunction with display devices and control of the display devices.

Web media often is played on computers rather than television displays. Although it is known to connect a computer to a television set in order to watch Web media, it is difficult to control such a system within the typical scenario for television watching where the viewer is positioned some distance from the television. Furthermore, although a wireless device can enable the user to control the television from a distance, it can be difficult to view a web browser display on the television set and may interfere with normal television program viewing by other persons.

Given the desire to watch various World Wide Web media on a family's primary television set, and to control this operation from the comfort of one's couch, there is a need to operate a television set or other display remotely from a personal computing device, such as a mobile phone. It also is desirable to allow a user to perform a general Web search to locate and capture Web media, and to control a television or other display remotely using the personal computing device.

SUMMARY

Various aspects of the invention are set forth in the claims.

For example, according to one aspect, a system for presenting and controlling content on a display device includes a network, a server system coupled to the network and comprising one or more servers, a display device coupled to the network and having a display, and a personal computing device operable to transmit a first message according to a specified format over the network to the server system. The server system stores an association between the personal computing device and the display device. The first message identifies user-selected content and a media player to play the content. The server system is operable, in response to receiving the first message from the personal computing device, to provide to the display device a second message identifying the user-selected content and the media player to play the content. In response to receiving the second message, the display device is operable to obtain a first media player needed to play the content, to load the media player and to present the content on the display.

In some implementations, the display device is operable, in response to receiving the second message, to obtain the first media player from the content provider only if the first media player is not already loaded in the display device.

In some implementations, the personal computing device is operable to transmit a message according to a specified

format over the network to the server system. The message can include a command for controlling playing of the content on the display device. The server system is operable, in response to receiving the message, to convert the command into a corresponding command recognizable by the media player if the command received from the personal computing device is not recognizable by the media player. The server system is operable to provide to the display device a message that includes the corresponding command, and the display device is operable, in response to receiving the message from the server system, to execute the command.

In some implementations, the personal computing device is, for example, a mobile phone, and the display device is a television set. Other personal computing devices or display devices can be used in other implementations. The network can include, for example, the Internet.

In some implementations, the server system stores a look-up table that includes a synchronization code uniquely associated with the display device. A message from the personal computing device can include the synchronization code, and in response to receiving the message from personal computing device, the server system can use the synchronization code and the look-up table to identify the display device on which the content is to be played. The synchronization code can be different from an IP address associated with the display device and/or a media access control address associated with the display device.

In various implementations, the system can facilitate allowing a personal computing device to be used to select different content to be played on a remote display even if different media players are required to present the different content. The system also can allow the user to control how the content is displayed on the display device using the personal computing device. For example, user-initiated play commands can be passed from the user's personal computing device, through the server system, to the display device.

Other aspects, features and advantages will be apparent from the following detailed description, the accompanying drawings, and the claims.

BRIEF DESCRIPTION OF THE DRAWINGS

FIG. 1 is a block diagram illustrating an example of a system according to the invention.

FIG. 2 illustrates various details of the flow of information and signals according to some implementations.

FIG. 3 illustrates an example of a transmission code incorporated into a message from a personal computing device.

FIG. 4 illustrates an example of a look-up table that forms part of a server system.

FIG. 5 illustrates an example of entries in a universal API adapter.

FIG. 6 is a flow chart showing steps for display device to load a video player and video.

FIG. 7A illustrates an example of a display device including a synchronization code.

FIG. 7B illustrates an example of a synchronization code look-up table.

FIGS. 8-13 illustrate examples of various scenarios in which the invention can be used.

FIGS. 14A through 14E illustrate examples of display screens that may appear on a user's personal computing device in accordance with the invention.

FIG. 15 illustrates further information that can be stored in the look-up table in the server system.

DETAILED DESCRIPTION

As shown in FIG. 1, a system 10 facilitates synchronizing a connection between two or more devices 20, 22 connected

to the Internet **21** or other computer network. The connection is designed to be made by a first device (e.g., a personal computing device) **20** that acts as a controller and a second device (e.g., a television set **22** with a display **23**) that acts as a receiver to play content selected by a user of the first device and to respond to commands that originate at the personal computing device. The personal computing device **20** is operable to display an application or web site that contains information and links to content providers **30** on the Internet **21**. The television set **22** is operable to link back to a server system **24** from which the television set receives commands. When a user makes a selection using the personal computing device **20** for particular content to be displayed on the television display **23**, a signal is sent through the Internet (or other network) **21** to the server system **24**. A corresponding command signal then is passed along to the connected television set **22**, which acts on a transmission code contained within the signal and performs specified commands. For example, in some scenarios, the command instructs the television set **22** to access a content provider **30** through the Internet **21**, load a specific media player, load the media player-specific content (e.g., a video) and play the content on the television display **23**. The user can use the personal computing device **20** to control how the content is played on the television display **23**. The user may subsequently visit the same or another Web site using the personal computing device **20** to select different content (e.g., a second video) to be played on the television display **23**. In that case, another signal would be sent through the server system **24** to the television set **22**. A transmission code associated with this command signal instructs the television set **22** to load a new media player (if needed) over the Internet and to load the specified video file to be played on the display **23**. Thus, the system **10** allows a personal computing device **20** to be used to select different content to be played on a remote display **23** even if different media players are required for the different content. The user also can control how the content is displayed (e.g., play, pause, stop, rewind, fast forward, etc.) on the display **23** using the personal computing device **20**. The user-initiated play commands are passed from the user's personal computing device **20**, through the server system **24**, to the television set **22**.

Although the following detailed discussion describes videos as an example of the type of content to be played on the display **23**, the system **10** can be used for other types of content as well. Thus, depending on the implementation, the content may include one or more of the following: video, audio, interactive video game, streaming media, multimedia, images, slides (e.g., a PowerPoint presentation) or other types of dynamic content. Furthermore, in the following discussion, it is assumed that the personal computing device **20** is a mobile phone that includes a display, an internal microprocessor or other processing circuitry, a keypad, keyboard, touchscreen, mouse, trackball, or other device to receive user selections and other input, and a transceiver to establish communications to the Internet **21** or other communications networks. More generally, however, the personal computing device **20** can be any type of handheld or other Internet-enabled personal computing device, including personal computers, e-books, kiosks, tablets, smart phones, media players, and motion and touch sensory interfaces. In some cases, input from the user can be received in forms other than tactile input (e.g., acoustic or speech).

FIG. 2 illustrates further details of the flow of information and signals according to some implementations. The personal computing device (e.g., mobile phone) **20** is operable to display an application or web site that contains information and links to content providers **30** on the Internet **21**. The user

operates the mobile phone **20** so as to start the application or access the web site (block **100**). In some implementations, a logo appears on the mobile phone's display. By selecting the logo, the user causes a menu to expand and present various options. The options can include, for example: (i) add new content to a playlist, (ii) play a listed item on a secondary device, (iii) play a listed item on the mobile phone **20**. If the user selects to add new content to the playlist, the user is presented with a screen that allows him to enter user-defined search parameters or to select predefined search parameters to request video data. The search parameters are sent from the mobile phone **20** as part of a request for video data that satisfy the search parameters (block **102**). The request is transmitted via the Internet **21** and through the server system **24** to the appropriate content provider web site. In response, the content provider **30** provides metadata (e.g., titles, links to the videos) for one or more video files that satisfy the search parameters (block **104**). The metadata can be provided to the mobile phone **20**, for example, in the form of an XML data file. Upon receiving the data file, the mobile phone **20** displays a list of one or more videos based on the information received from the content provider **30** (block **106**).

If desired, the user can take one of several actions, including selecting one of the videos from the displayed list to be played on the television display **23** or initiating a command with respect to a video that already has been loaded to the television set **22** (block **108**). The mobile phone **20** then formats and transmits a message to the server system **24** (block **110**). The message from the mobile phone **20** contains a transmission code that includes data regarding the user information (e.g., user identification or account number), the secondary display it wants to connect to (e.g., television set **22** with display **23**), the location and name of the media player for the selected video, the command (e.g., play, pause, rewind, etc.), and the video file to be acted upon. An example of the format of a transmission code from the mobile phone **20** to the server system **24** is illustrated in FIG. 3. Different formats and/or different information may be appropriate for other implementations.

The message from the mobile phone **20** is transmitted over the Internet **21** and is received by the server system **24** (block **112**). Based on information in the message from the mobile phone **20**, the server system **24** verifies that the user has an account (block **114**), and the contents of the message, as well as the date and time of receipt of the message, are added to a personal computing device database **32** (block **116**) which forms part of a switchboard **28**. In general, all messages from a particular user's personal computing device **20** are stored in the database **32** corresponding to an account for the particular user. Thus, the database **32** stores a record of all messages received from a user's personal computing device **20**, as well as the user's identification, an indication of the target device **22**, an identification of the media player that is required for the selected video, and an identification of the selected video.

The switchboard **28** also includes a look-up table **34** that stores a correspondence between a particular personal computing device (such as mobile phone **20**) and target devices (e.g., the television set **22**) to which the user command is directed. An example of the look-up table **28** is illustrated in FIG. 4. In this example, it is assumed that, at most, a single connection is established at any given time between a particular mobile phone and a display device. However, as explained below, other scenarios are also possible to establish group connections (e.g., multiple mobile phones connected to the same display device). The server system **24** performs a target verification (block **118**), which includes checking whether a connection to a particular display device already is estab-

5

lished for the mobile phone **20** and, if so, checking the identification of the display device. During the target verification, if the look-up table indicates that there is no connection established between the mobile phone **20** and a particular display device, then the server system **24** sends a message to the mobile phone **20** to prompt the user to identify the device on which the video is to be displayed.

A user can identify the device on which the video is to be displayed in one of several ways, depending on the implementation. In some implementations, the user can select the display device from a list of devices displayed on the mobile phone **20**. The list can include a field populated with names or identifications of display devices that previously have been initialized for connection. Alternatively, the user can select the display device by entering a synchronization code uniquely associated with the particular display device. As illustrated in FIG. 7A, the synchronization code **48** can be displayed, for example, on a splash page of the display device as text on the screen or as an image such as a QR code and can be entered into the mobile phone **20**, for example, manually by the user or by scanning the code into the mobile phone. The code can be scanned, for example, using optical scanning or RFID techniques. Preferably, the synchronization code is different from the IP address associated with the device **22**. The IP address also can be different from the media access control (MAC) address associated with the device **22**. For example, in some implementations, the synchronization code is generated randomly and assigned to the display device **22** each time it connects to the server system **24**. Thus, a particular display device **22** may have an IP address, a MAC address, a web or browser cookie, and a synchronization code (“sync code”) assigned to it at any given time. This information can be stored, for example, in a look-up table in the server system **24**. An example of entries in such a look-up table are illustrated in FIG. 7B.

Once the synchronization code is entered into, or captured by, the mobile phone **20**, it is sent from the mobile phone **20** to the server system **24**, which stores the information in the look-up table **36** so as to establish a connection between the mobile phone **20** and the display device **22** through the server system **24**.

Once a connection is established between the mobile phone **20** and the display device **22**, signals sent from the mobile device **20** to its associated database **32** are copied to a database **34** associated with the target device (e.g., television set **24**) based on the correspondence between the mobile device and the target device listed in the look-up table **36** (block **122**). Thus, the database **32** entries associated with a particular display device (e.g., television set **24**) provide a record of the messages received for that display device, as well as an indication of the identification of the device that sent each message, an indication of the media player required to play the video, and an indication of the selected video.

In the illustrated implementation, the command in the transmission code (see FIG. 3) contains a JavaScript reference to control the media player needed to play the selected video. Various types of video players may use different JavaScript commands to control their respective playback. Therefore, in the illustrated implementation, a universal adapter **26** is provided to interpret and convert a standard or universal command (e.g., play, pause, etc.) into the specific command recognized by the media player. Each time a signal is received from the mobile device **20**, the API adapter **26** checks and identifies the specific media player that is being requested. Based on this information, the system loads the appropriate set of protocols or application programming interfaces (APIs) from its library and converts the incoming commands from

6

the mobile device **20** into the correct JavaScript (or other programming) code used by the target device **22** to control the specific player (block **120**). The server system **24** then copies the converted version of the message to the database **34** associated with the target device **22**, as indicated above in connection with block **122**.

The universal adapter **26** can be implemented, for example, as a look-up table. Examples of entries in such a look-up table are illustrated in FIG. 5. Thus, for a universal command “New Video,” the universal adapter **26** provides the corresponding command for each of several specific media players (e.g., “yt_loadVideo” for YouTube). Similarly, for a universal command “Pause,” the universal adapter **26** provides the corresponding command for each of several specific media players (e.g., “pauseVideo” for Ted.com). Other universal commands and the corresponding command(s) for one of more media players also can be stored by the universal adapter **26**.

The display device **22** periodically checks the entries in the database **34** to determine if there are any new messages/commands directed to it (block **124**). For example, in some implementations, the display device **22** polls the associated database **34** at some predetermined time interval. In some implementations, instead of the display device **22** periodically checking whether there are any messages for it in the database **34**, the server system **24** can push the messages to the display device **22**. In any event, the system is arranged so that the display device **22** receives the messages intended for it.

When the display device **22** receives a message from the server system **24** (block **126**), the display device executes the message (block **128**). In some cases, the media player required to play the video indicated in the message is not presently loaded in the display device **22**. For example, the received command may be to “play” a particular video. As indicated by FIG. 6, if the media player needed to play the video is not already loaded in the display device **22**, the display device **22** requests and obtains a copy of the appropriate media player **40** and a copy of the video file **42** from a content provider **30**, loads the media player and then presents the video on the display **23** (FIG. 2, block **130**). Likewise, as indicated by FIG. 6, if the appropriate media player already is loaded in the display device, but the particular video is not, then the display device **22** requests and obtains a copy of the video file **42** from the content provider **30** and proceeds to play the video. To allow the display device **22** to switch between different video players (i.e., to load and unload different video players), a software program can be stored on the display device and/or the web site to establish a secure connection back to the server system **24**.

Once the video is playing on the display device **22**, the user of the mobile phone **20** can control the playing of the video by entering appropriate commands (e.g., pause, fast forward, rewind, stop, play, etc.) through the mobile phone. Each command is incorporated into a message including a transmission code (FIG. 3) as described above. The message is transmitted to the server system **24**, which copies the message into database entries associated with the particular display device **22** (i.e., after performing any conversion of the command by the API adapter **26**). Once the message is retrieved by or sent to the display device **22**, the display device proceeds to execute the command.

The system and methods described here allow a user of a mobile phone or other personal computing device to create a playlist based on videos (or other types of content) from multiple sources and to play back each video using a single interface that can be used to control different media players.

As mentioned above, the system and methods described above also can be used with types of content other than video. In that case, different types of user-initiated commands may be available to control the content displayed on the display **23**. For example, for interactive video games, the user-initiated commands can include control commands appropriate for the particular game.

Although the implementation of FIG. **1** illustrates the display device **22** as a television set with a display screen **23**, other types of display devices can be used as well (e.g., a laptop or personal computer).

The systems and methods can be used in various scenarios to play back videos (or other content). Examples of several scenarios that can be implemented using the system described above are described in the following paragraphs. For example, a first scenario involves a single user's smartphone connecting to a single display device (FIG. **8**). In this scenario, the user turns on, for example, her display device (e.g., personal computer with a display monitor), opens up a browser and accesses a website associated with the server system **24**. The user then clicks on a link that launches the software program to establish a secure connection back to the server system **24**. The software program opens a splash page (see FIG. **14A**), and a sync-code is displayed on the monitor. The user then opens the appropriate application on her smartphone. In the smartphone application, the user accesses a "Connect" screen from which he can select one of several listed display devices (see FIG. **14B**). Alternatively, the user can enter the sync-code displayed on the computer monitor (see FIG. **14B**). The user then clicks on a SEND button which causes a message including the sync-code to be sent the server system **24**. In response, the server system **24** establishes a connection between the user's smartphone and the selected display device through a look-up table as described above with respect to FIG. **4**. The user can use a search tool in the smartphone application to find a video. In response to the search, a list of videos satisfying the search appears on the smartphone (see FIG. **14C**). When the user selects a video from the list displayed on the smartphone, the information is provided through the server system **24** to the personal computer. In some implementations, a pop-up window may appear on the smartphone listing one or more options for the user to take regarding the selected video. Such options can include, for example, play the video on the selected display device (e.g., the personal computer), play the video on the smartphone, or add the video to the playlist on the smartphone. If the user chooses to have the video played on the display device (e.g., the personal computer), the personal computer obtains a copy of the required video player and the selected video from an appropriate content provider over the Internet and begins to play the video on the monitor as described previously. In some implementations, a message is displayed on the user's smartphone indicating that the selected video is playing and providing additional information about the selected video (see FIG. **14D**). The user can control playing of the video (e.g., pause, fast forward, rewind, play, etc.) from her smartphone.

A second scenario involves saving a selected video to a playlist on a single user's smartphone, and subsequently playing the video on a display device (FIG. **9**). In this scenario, the user opens the appropriate application on his smartphone and searches for videos using the search tool displayed in the application. When a list of videos is displayed on the smartphone in response to the search request, the user selects one or more videos to add to his playlist. At that time, or at a later time, the user can connect to a display device through the server system **24**. To do so, the user opens the playlist on his

smartphone and selects a video. The information is provided through the server system **24** to the display device, which obtains a copy of the required video player and the selected video from an appropriate content provider over the Internet and begins to play the video. The user can control playing of the video (e.g., pause, fast forward, rewind, play, etc.) from his smartphone.

A third scenario involves multiple users' smartphones and a single display device (FIG. **10**). For example, a user may want to share and watch videos with a group of friends watching together on a single display device. In this situation, the user can access the application or web site to set up a group and serve as the moderator for the group. The user then can send out a request to other members of the group, or other users can send a request to the moderator to join the group. Users can search for other users based, for example, on username or from a contact list. The moderator then can select a user in the group to control the display device. FIG. **14E** illustrates an example of a screen on the user's smartphone that allows the user to connect with other users to form a group and to select which member of the group controls the display device (e.g., by selecting a member of the group from the list "Me, Guest 1, Guest 2, . . ." near the top of the screen). Alternatively, the moderator can set it up so that control is passed to each member of the group in turn automatically, or so that the next turn can be determined by consensus of the entire group, via some form of voting. Regardless of who has control of the display device **22**, each user in the group retains control of his own smartphone. The look-up table **36** in the server system **24** stores the connections established between the personal computing devices of the users in the group and the display device (see FIG. **15**).

A fourth scenario involves one user's smartphone and multiple display devices (FIG. **11**). In this example, a user opens the application on his smartphone to establish a connection to a first display device and then repeats the process for multiple display devices. A list of devices that the user's smartphone is connected to is displayed on the smartphone. The user can choose to control all devices simultaneously or one at a time. To do so, the user selects from the list the display device(s) he wants to control. The user then can search for videos using his smartphone. In response to the user selecting a particular video, the selected video is played on the selected display device(s).

A fifth scenario involves multiple users' smartphones and multiple connected display devices (FIG. **12**). For example, a user may want to share and watch videos with a group of friends, who may be in different locations each of which has a separate display device. Each user establishes a connection from her smartphone to the display device where she is located. One of the users uses the application or web site to establish a group, with the user who establishes the group serving as the group moderator. The user can send out a request to other users to join the group or other users can send a request to the moderator to join the group. In some implementations, users can search for other users based on username or from a contact list. The moderator chooses which member of the group has control of the display device. Alternatively, the moderator can set it up control is passed to each member of the group in turn automatically, or so that the next turn can be determined by consensus of the entire group, via some form of voting. The signal sent from the smartphone of the group member who has control is sent (via the server system **24**) to all display devices within the group. Regardless of which group member has control of the display devices, each user retains control of her own smartphone. The look-up table **36** in the server system **24** stores the connections estab-

lished between the personal computing devices of the users in the group and the display devices (see FIG. 15).

A sixth scenario involves sharing video links and a playlist (FIG. 13). For example, a user within a group can share a video playlist and video links via an Instant messaging system built-in to the application. Users also can post video links or a video playlist to third-party web sites (e.g., social networking sites). Other users can view the video link and playlist within the application. When a video from the list is selected, it plays on the selected device.

The system and methods can be used by a wide variety of users in addition to individual viewers. For example, companies that provide on-line video platforms that host videos for other individuals or companies can obtain useful advantages by integrating the platforms with the server system 24. Programming hooks can be created in the API so that the on-line video platform's media player can communicate with the server system 24. When media player commands for an on-line video platform are added to the system 24, the media player's API is placed in an API library and is stored in the API adapter 26. The on-line video platform can then offer customers the ability to add videos to their own mobile web sites that are enabled to operate with the server system 24.

The system and methods also can be used by content providers. For example, the content provider may want to deliver its media on-line. The content provider can use an on-line video platform that is enabled to operate with the server system 24. In some implementations, the content provider is allowed to add links to videos for that web site (i.e., mobile site or an application). The link facilitates synchronization to the secondary device 22 (e.g., a television set) and allows the end-user to load and control the video on the secondary device.

As used in this disclosure, terms such as "first," "second," etc. with respect to the messages are used simply as labels to distinguish the various messages from one another. Such terms do not imply that there cannot be any other messages prior to the first message or that there cannot be other messages between the first and second messages.

Implementations of the subject matter and the operations described in this specification can include digital electronic circuitry, or in computer software, firmware, or hardware, including the structures disclosed in this specification and their structural equivalents, or in combinations of one or more of them. Implementations of the subject matter described in this specification can include one or more computer programs, i.e., one or more modules of computer program instructions, encoded on computer storage medium for execution by, or to control the operation of, data processing apparatus. Alternatively or in addition, the program instructions can be encoded on an artificially-generated propagated signal, e.g., a machine-generated electrical, optical, or electromagnetic signal that is generated to encode information for transmission to suitable receiver apparatus for execution by a data processing apparatus. A computer storage medium can be, or can be included in, a computer-readable storage device, a computer-readable storage substrate, a random or serial access memory array or device, or a combination of one or more of them. Moreover, while a computer storage medium is not a propagated signal, a computer storage medium can be a source or destination of computer program instructions encoded in an artificially-generated propagated signal. The computer storage medium can also be, or be included in, one or more separate physical components or media (e.g., multiple CDs, disks, or other storage devices).

The operations described in this specification can include operations performed by a data processing apparatus on data

stored on one or more computer-readable storage devices or received from other sources. The term "data processing apparatus" encompasses all kinds of apparatus, devices, and machines for processing data, including by way of example a programmable processor, a computer, a system on a chip, or multiple ones, or combinations, of the foregoing. The apparatus and execution environment can realize various different computing model infrastructures, such as web services, distributed computing and grid computing infrastructures.

A computer program (also known as a program, software, software application, script, or code) can be written in any form of programming language, including compiled or interpreted languages, declarative or procedural languages, and it can be deployed in any form, including as a stand-alone program or as a module, component, subroutine, object, or other unit suitable for use in a computing environment. A computer program may, but need not, correspond to a file in a file system. A program can be stored in a portion of a file that holds other programs or data (e.g., one or more scripts stored in a markup language document), in a single file dedicated to the program in question, or in multiple coordinated files (e.g., files that store one or more modules, sub-programs, or portions of code). A computer program can be deployed to be executed on one computer or on multiple computers that are located at one site or distributed across multiple sites and interconnected by a communication network.

Processors suitable for the execution of a computer program include, by way of example, both general and special purpose microprocessors, and any one or more processors of any kind of digital computer. Generally, a processor will receive instructions and data from a read-only memory or a random access memory or both. Elements of a computer include a processor for performing actions in accordance with instructions and one or more memory devices for storing instructions and data.

Generally, a computer will also include, or be operatively coupled to receive data from or transfer data to, or both, one or more mass storage devices for storing data, e.g., magnetic, magneto-optical disks, or optical disks. However, a computer need not have such devices. Moreover, a computer can be embedded in another device, e.g., a mobile telephone, a personal digital assistant (PDA), a mobile, audio or video player, a game console, a Global Positioning System (GPS) receiver, or a portable storage device (e.g., a universal serial bus (USB) flash drive), to name just a few. Devices suitable for storing computer program instructions and data include all forms of non-volatile memory, media and memory devices, including by way of example semiconductor memory devices, e.g., EPROM, EEPROM, and flash memory devices; magnetic disks, e.g., internal hard disks or removable disks; magneto-optical disks; and CD-ROM and DVD-ROM disks. The processor and the memory can be supplemented by, or incorporated in, special purpose logic circuitry.

Although this specification contains many specific implementation details, these should not be construed as limitations on the scope of any inventions or of what may be claimed, but rather as descriptions of features specific to particular implementations of particular inventions. Certain features that are described in this specification in the context of separate implementations can also be implemented in combination in a single implementation. Conversely, various features that are described in the context of a single implementation can also be implemented in multiple implementations separately or in any suitable subcombination. Moreover, although features may be described above as acting in certain combinations and even initially claimed as such, one or more features from a claimed combination can in some cases be excised from the

11

combination, and the claimed combination may be directed to a subcombination or variation of a subcombination.

Similarly, while operations are depicted in the drawings in a particular order, this should not be understood as requiring that such operations be performed in the particular order shown or in sequential order, or that all illustrated operations be performed, to achieve desirable results. In certain circumstances, multitasking and parallel processing may be advantageous. Moreover, the separation of various system components in the implementations described herein and the attachments hereto should not be understood as requiring such separation in all implementations, and it should be understood that the described program components and systems can generally be integrated together in a single software product or packaged into multiple software products.

Thus, although particular implementations have been described, other implementations are within the scope of the claims.

What is claimed is:

1. A machine-implemented method of controlling presentation of video content on a display device that loads any one of a plurality of different media player players, the method comprising:

assigning, by a server system, a synchronization code to the display device;

receiving, in the server system, a message from a personal computing device that is separate from the server system and separate from the display device, wherein the message includes the synchronization code;

storing, by the server system, a record establishing an association between the personal computing device and the display device based on the synchronization code;

receiving, in the server system, one or more signals from the personal computing device, the one or more signals specifying a video file to be acted upon and identifying a particular media player for playing the video content, the one or more signals further including a universal playback control command for controlling playing of the video content on the display device by the particular media player,

converting, by the server system, the universal playback control command into corresponding programming code to control playing of the video content on the display device by the particular media player, wherein converting the universal playback control command includes selecting from among a plurality of specific commands, each of which represents a corresponding playback control command for a respective media player; and

storing, in a database associated with the server system, information for transmission to or retrieval by the display device, wherein the information specifies the video file to be acted upon, identifies the particular media player for playing the video content, and includes the corresponding programming code to control playing of the video content on the display device by the particular media player in accordance with the universal playback control command.

2. The method of claim 1 including:

checking, in the server system, the identity of the media player identified in the one or more signals from the personal computing device;

loading an appropriate set of protocols or application programming interfaces from a library based on the identity of the media player; and

12

converting the command from the personal computing device into corresponding code to control the media player.

3. The method of claim 1 wherein converting the command into corresponding programming code to control the media player includes using information in a look-up table.

4. The method of claim 3 wherein the look-up table stores a plurality of specific commands, each of which represents, respectively, a corresponding command for a different media player.

5. The method of claim 1 wherein the universal command represents an instruction to play the video content, to stop playing the video content or to pause playing the video content.

6. The method of claim 1 wherein the video content is an interactive video game.

7. The method of claim 1 wherein the video content is streaming media.

8. The method of claim 1 wherein the synchronization code is uniquely associated with the display device on which the video content is to be played.

9. The method of claim 8 wherein the synchronization code is different from an IP address associated with the display device and is different from a MAC address associated with the display device.

10. The method of claim 8 wherein assigning a synchronization code includes assigning a randomly generated code to the display device each time the display device connects to the server system.

11. A system for controlling playing of video content on a display device that loads any one of a plurality of different media players, the system comprising:

a server system;

a first database storing a relationship between a personal computing device and the display device based on a synchronization code assigned by the server system to the display device and received by the server system in a message from the personal computing device, wherein the personal computing device is separate from the server system and separate from the display device; and a second database;

wherein the server system is configured to receive one or more signals from the personal computing device, the one or more signals specifying a video file to be acted upon and identifying a particular media player for playing the video content, the one or more signals further including a universal playback control command for controlling playing of the video content on the display device,

one or more non-transitory computer-readable media storing instructions that when executed by the server system, cause the server system to perform operations including converting the universal playback control command into corresponding programming code to control playing of the video content of the particular media player, wherein converting the universal playback control command includes selecting from among a plurality of specific commands, each of which represents a corresponding playback control command for a respective media player;

the server system being further configured to store in the second database information for transmission to or retrieval by the display device, wherein the information specifies the video file to be acted upon, identifies the particular media player for playing the video content, and includes the corresponding programming code to control playing of the video content on the display

13

device by the particular media player in accordance with the universal playback control command.

12. The system of claim 11 including:

library storing protocols or application programming interfaces,

wherein the server system is configured to check the identity of the media player identified in the one or more signals from the personal computing device, load an appropriate set of protocols or application programming interfaces from the library based on the identity of the media player, and convert the command from the personal computing device into a corresponding programming code used by the display device to control the media player.

13. The system of claim 11 including:

a look-up table storing a plurality of commands each of which is for a particular type of media player,

wherein the server system is configured to convert the command into corresponding programming code to control the media player based on information in the look-up table.

14. The system of claim 11 wherein the look-up table stores a correspondence between the universal command and a plurality of specific commands, each of which is for a different media player.

15. The system of claim 14 the server system is configured to convert the universal command by selecting from among the plurality of specific commands stored in the look-up table.

16. The system of claim 11 wherein the universal command represents an instruction to play the video content, to stop playing the video content or to pause playing the video content.

17. The system of claim 11 wherein the video content is an interactive video game.

18. The system of claim 11 wherein the video content is streaming media.

19. The system of claim 11 wherein the synchronization code is uniquely associated with the display device on which the video content is to be played.

20. The system of claim 19 wherein the synchronization code is different from an IP address associated with the display device and is different from a MAC address associated with the display device.

21. The system of claim 19 wherein the server system is configured to assign as the synchronization code a randomly generated code each time the display device connects to the server system.

22. An automated machine-implemented method of presenting video content on a display device that loads any one of a plurality of different media player, the method comprising: displaying, by the display device, a synchronization code that was assigned to the display device by a server system, the server system subsequently storing, based on a message from a personal computing device that is sepa-

14

rate from the server system and the display device, an association between the display device and the personal computing device, the message from the personal computing device including the synchronization code;

retrieving, by the display device from a server system, first information that specifies a first video file to be acted upon, that identifies a first media player for playing the first video file, and that indicates corresponding programming code to control playing of the first video file on the display device by the first media player in accordance with a first playback control command, wherein the server system previously received, from the personal computing device, one or more signals specifying the first video file identifying the first media player and including the first playback control command;

obtaining, by the display device, over the Internet the first media player for playing the first video file;

loading the first media player in the display device;

executing the first playback control command with respect to the first video file using the first media player;

subsequently retrieving, by the display device from the server system, second information that specifies a second video file to be acted upon, that identifies a second media player different from the first media player for playing the second video file, and that indicates corresponding programming code to control playing of the second video file on the display device by the second media player in accordance with a second playback control command, wherein the server system previously received, from the personal computing device, one or more signals specifying the second video file, identifying the second media player and including the second playback control command;

obtaining, by the display device, over the Internet the second media player for playing the second video file;

loading the second media player in the display device; and executing the second playback control command with respect to the second video file using the second media player.

23. The method of claim 22 wherein the display device comprises a television set with a display screen.

24. The method of claim 22 wherein the display device comprises a laptop or personal computer.

25. The method of claim 22 wherein each of the first and second commands represents an instruction to play the respective video file, to stop playing the respective video file or to pause playing the respective video file.

26. The method of claim 22 wherein the display device checks whether the respective media player needed to play the particular one of the video files already is loaded in the display device before obtaining a copy of the media player over the Internet.

* * * * *

UNITED STATES PATENT AND TRADEMARK OFFICE
CERTIFICATE OF CORRECTION

PATENT NO. : 8,356,251 B2
APPLICATION NO. : 13/245001
DATED : January 15, 2013
INVENTOR(S) : David Strober

Page 1 of 1

It is certified that error appears in the above-identified patent and that said Letters Patent is hereby corrected as shown below:

Col. 11, line 24, Claim 1, change “player players,” to -- players, --;

Col. 12, line 55, Claim 11, change “of” to -- by --;

Col. 13, line 4, Claim 12, before “library” insert -- a --;

Col. 13, line 13, Claim 12, after “code” delete “used by the display device”;

Col. 13, line 50, Claim 22, change “player,” to -- players, --;

Col. 14, line 5, Claim 22, change “a” to -- the --;

Col. 14, line 14, Claim 22, change “file” to -- file, --.

Signed and Sealed this
Ninth Day of April, 2013



Teresa Stanek Rea
Acting Director of the United States Patent and Trademark Office