



US009569777B2

(12) **United States Patent**
Colby

(10) **Patent No.:** **US 9,569,777 B2**

(45) **Date of Patent:** ***Feb. 14, 2017**

(54) **EPASSPORT INCLUDING SHIELDING METHOD**

5/00;G06K 19/07345; G06K 19/0723; G06K 19/073; G06K 19/07; H01Q 1/526; G08B 13/14
(Continued)

(71) Applicant: **Mynette Technologies, Inc.**, Menlo Park, CA (US)

(56) **References Cited**

(72) Inventor: **Steven Michael Colby**, Mountain View, CA (US)

U.S. PATENT DOCUMENTS

(73) Assignee: **Mynette Technologies, Inc.**, Menlo Park, CA (US)

4,575,601 A 3/1986 Taguchi et al.
4,744,497 A 5/1988 O'Neal
(Continued)

(*) Notice: Subject to any disclaimer, the term of this patent is extended or adjusted under 35 U.S.C. 154(b) by 0 days.

FOREIGN PATENT DOCUMENTS

This patent is subject to a terminal disclaimer.

DE 10 2004 008 840 A1 9/2005
JP 11-348471 A 12/1999
(Continued)

(21) Appl. No.: **14/660,825**

OTHER PUBLICATIONS

(22) Filed: **Mar. 17, 2015**

U.S. Appl. No. 14/659,072, Steven Michael Colby, RFID Security System, filed Mar. 16, 2015.

(65) **Prior Publication Data**

US 2015/0294295 A1 Oct. 15, 2015

(Continued)

Related U.S. Application Data

Primary Examiner — Hung T Nguyen
(74) *Attorney, Agent, or Firm* — Peters Verny LLP

(63) Continuation-in-part of application No. 13/481,104, filed on May 25, 2012, now abandoned, which is a
(Continued)

(57) **ABSTRACT**

(51) **Int. Cl.**
G06Q 20/40 (2012.01)
G06Q 20/22 (2012.01)
(Continued)

Shielding is associated with RFID tags to achieve new systems and methods having various advantages. These systems include containers configured to store RFID enabled identity documents, the use of RFID tags to monitor the state of a container, and the inclusion of shielding in identity devices. Disclosed are shielded passports, driver's licenses, and the like. Some embodiments further including reading systems for reading identity devices comprising shielding and RFID tags. Further, various switchable RFID devices are disclosed. These switchable RFID devices may include one or more RFID tags and one or more switches. Some of these one or more switches are optionally wireless. In various embodiments, the switchable RFID devices include identity devices, financial devices, remote controls, and the like.

(52) **U.S. Cl.**
CPC **G06Q 20/4012** (2013.01); **G06K 19/07709** (2013.01); **G06Q 20/227** (2013.01); **G06Q 20/3278** (2013.01)

(58) **Field of Classification Search**
CPC G06K 19/00; G06K 19/025; G06K 19/06; G06K 19/07327; G06K 19/07749; G06K

25 Claims, 35 Drawing Sheets

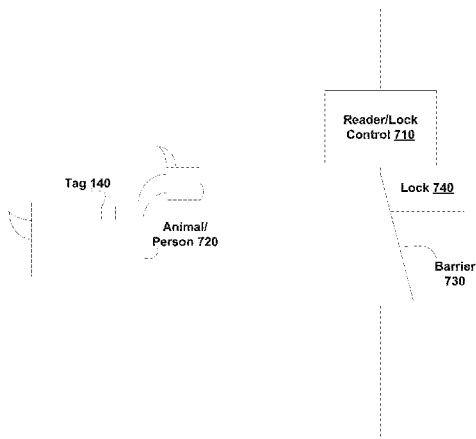

Related U.S. Application Data

continuation of application No. 12/777,474, filed on May 11, 2010, now abandoned, which is a continuation of application No. 11/350,309, filed on Feb. 7, 2006, now Pat. No. 7,719,425, application No. 14/660,825, which is a continuation-in-part of application No. 13/084,433, filed on Apr. 11, 2011, which is a continuation-in-part of application No. 11/458,620, filed on Jul. 19, 2006, now Pat. No. 7,924,156, which is a continuation-in-part of application No. 11/382,052, filed on May 7, 2006, now abandoned, and a continuation-in-part of application No. 11/382,053, filed on May 7, 2006, now abandoned, and a continuation-in-part of application No. 11/382,054, filed on May 8, 2006, now abandoned, and a continuation-in-part of application No. 11/382,264, filed on May 8, 2006, now abandoned, and a continuation-in-part of application No. 11/382,265, filed on May 8, 2006, now abandoned, and a continuation-in-part of application No. 11/420,721, filed on May 26, 2006, now abandoned, said application No. 13/084,433 is a continuation-in-part of application No. 11/382,050, filed on May 7, 2006, now abandoned, application No. 14/660,825, which is a continuation-in-part of application No. 14/468,110, filed on Aug. 25, 2014, now Pat. No. 9,495,852, which is a continuation of application No. 12/577,209, filed on Oct. 12, 2009, now Pat. No. 8,816,826, which is a continuation-in-part of application No. 11/382,050, filed on May 7, 2006, now abandoned, said application No. 12/577,209 is a continuation-in-part of application No. 11/382,052, filed on May 7, 2006, now abandoned, and a continuation-in-part of application No. 11/382,053, filed on May 7, 2006, now abandoned, and a continuation-in-part of application No. 11/382,054, filed on May 8, 2006, now abandoned, and a continuation-in-part of application No. 11/382,264, filed on May 8, 2006, now abandoned, and a continuation-in-part of application No. 11/382,265, filed on May 8, 2006, now abandoned, and a continuation-in-part of application No. 11/420,721, filed on May 26, 2006, now abandoned.

- (60) Provisional application No. 60/650,478, filed on Feb. 7, 2005, provisional application No. 60/678,428, filed on May 6, 2005, provisional application No. 60/685,331, filed on May 27, 2005, provisional application No. 60/700,884, filed on Jul. 19, 2005, provisional application No. 60/712,308, filed on Aug. 30, 2005, provisional application No. 60/715,641, filed on Sep. 10, 2005, provisional application No. 60/752,933, filed on Dec. 21, 2005, provisional application No. 60/758,751, filed on Jan. 13, 2006, provisional application No. 60/782,068, filed on Mar. 13, 2006, provisional application No. 60/744,154, filed on Apr. 3, 2006, provisional application No. 60/746,636, filed on May 6, 2006.

- (51) **Int. Cl.**
G06Q 20/32 (2012.01)
G06K 19/077 (2006.01)

- (58) **Field of Classification Search**
 USPC 340/572.1, 572.3, 572.7, 572.8,
 539.1,340/825.69, 10.1, 10.3; 235/375,
 380, 383, 487, 235/492; 343/702, 841
 See application file for complete search history.

(56)

5,206,495	A
5,327,115	A
5,380,046	A
5,506,395	A
5,521,590	A
5,538,291	A
5,640,151	A
5,686,902	A
5,700,037	A
5,847,662	A
5,966,082	A
6,130,602	A
6,144,299	A
6,158,777	A
6,199,762	B1
6,282,407	B1
6,320,169	B1
6,471,127	B2
6,531,964	B1
6,593,845	B1
6,719,206	B1
7,015,791	B2
7,051,205	B1
7,218,233	B2
7,246,754	B2
7,290,709	B2
7,446,646	B2
7,591,415	B2
7,701,408	B2
7,719,425	B2
7,832,771	B2
7,924,156	B2
2001/0017799	A1
2002/0017557	A1
2002/0047777	A1
2002/0117243	A1
2003/0014891	A1
2003/0030568	A1
2003/0042318	A1
2003/0057286	A1
2003/0095034	A1
2003/0209601	A1
2004/0089724	A1
2004/0145453	A1
2004/0169087	A1
2004/0212503	A1
2004/0233040	A1
2004/0237360	A1
2004/0256469	A1
2004/0263319	A1
2005/0011776	A1
2005/0093703	A1
2005/0145688	A1
2005/0171898	A1
2005/0174239	A1
2005/0192053	A1
2005/0205665	A1
2005/0207229	A1
2005/0236489	A1*
2005/0242950	A1
2005/0253683	A1
2005/0263591	A1
2005/0274794	A1
2006/0005050	A1
2006/0109084	A1
2006/0164250	A1
2006/0186989	A1
2006/0187040	A1
2006/0245530	A1
2006/0254815	A1
2006/0266831	A1
2007/0024423	A1
2007/0057790	A1
2007/0057792	A1

References Cited

U.S. PATENT DOCUMENTS

4/1993	Kreft
7/1994	Swierczek
1/1995	Stephens
4/1996	Eppley
5/1996	Hanaoka et al.
7/1996	Gustafson
6/1997	Reis et al.
11/1997	Reis et al.
12/1997	Keller
12/1998	Yokota et al.
10/1999	Cofino et al.
10/2000	O'Toole et al.
11/2000	Cole
12/2000	Twardosz
3/2001	Hohle
8/2001	Vega et al.
11/2001	Clothier
10/2002	Pentz et al.
3/2003	Loving
7/2003	Friedman et al.
4/2004	Bashan et al.
3/2006	Huntzicker
5/2006	Horiguchi et al.
5/2007	Bon
7/2007	Siuta et al.
11/2007	Tsai et al.
11/2008	Huomo
9/2009	Jesme
4/2010	Bombay et al.
5/2010	Colby
11/2010	Hoepfner et al.
4/2011	Colby
8/2001	Chen et al.
2/2002	Hendrick
4/2002	Casden
8/2002	Koren
1/2003	Nelms et al.
2/2003	Lastinger et al.
3/2003	Krishna et al.
3/2003	Yamagishi et al.
5/2003	Clothier
11/2003	Chung
5/2004	Lasch et al.
7/2004	Tuttle
9/2004	Lasch et al.
10/2004	Stilp
11/2004	Lane et al.
12/2004	Nelms et al.
12/2004	Faenza, Jr. et al.
12/2004	Huomo
1/2005	Nagel
5/2005	Twitchell, Jr.
7/2005	Milenkovic et al.
8/2005	Bishop et al.
8/2005	Shanks et al.
9/2005	Kao et al.
9/2005	Lasch et al.
9/2005	Takeuchi
10/2005	Droz G06K 19/025 235/487
11/2005	Lindsay et al.
11/2005	Lowe
12/2005	Smith
12/2005	Bason et al.
1/2006	Basson et al.
5/2006	Yarvis
7/2006	Kawai
8/2006	Chon et al.
8/2006	Sweeny
11/2006	Pradhan et al.
11/2006	Humphrey et al.
11/2006	Kozlay
2/2007	Nikitin et al.
3/2007	Alden et al.
3/2007	Alden

(56)

References Cited

U.S. PATENT DOCUMENTS

2007/0075140 A1 4/2007 Guez et al.
 2007/0090927 A1 4/2007 Potyrailo et al.
 2007/0152829 A1 7/2007 Lindsay et al.
 2007/0164866 A1 7/2007 Robin et al.
 2007/0194116 A1 8/2007 Arnold
 2008/0169901 A1 7/2008 Timm et al.
 2008/0238679 A1 10/2008 Rofougaran et al.

FOREIGN PATENT DOCUMENTS

WO 0016570 A1 3/2000
 WO 2005/062246 A1 7/2005

OTHER PUBLICATIONS

- U.S. Appl. No. 14/468,110, Steven M. Colby, Electronically Switchable RFID Tags, filed Aug. 25, 2014.
 U.S. Appl. No. 14/660,907, Steven Michael Colby, Mechanically Programmable RFID, filed Mar. 17, 2015.
 U.S. Appl. No. 14/660,927, Steven Michael Colby, RFID Sensor, filed Mar. 17, 2015.
 Juels, Ari, et al. "Security and Privacy Issues in E-passports", SECURECOMM'05, vol. 00 2005, Sep. 5, 2009, pp. 1-12.
 Peterson, Erik, "US Issues First e-passports to diplomats, citizen issuance to start later in '06", SecureID News, Apr. 20, 2006, 3 pages.
 Moss, Frank, "How the US Passport Program Enhances Border Security", travel.state.gov, Jun. 22, 2005, 5 pages.
 Unknown, "CDT Working Group on RFID: Privacy Best Practices for Deployment of RFID Technology", www.cdt.org, May 1, 2006, 7 pages.
 Moss, Frank, Statement, Committee on International Relations, www.house.gov, Jun. 23, 2004, 4 pages.
 Goo, Sara Kehaulani, "Security Concerns Prompt Passport Redesign", www.washingtonpost.com, Apr. 30, 2005, 3 pages.
 Unknown, "Information Security Radio Frequency Identification Technology in the Federal Government", GAO-05-551, May 27, 2005, 41 pages.
 Yoshida, Junko, "Tests Reveal e-Passport Security Flaw", www.eetimes.com, Aug. 30, 2004, 3 pages.
 Unknown, "Characteristics of Metal Shielding Textiles", www.rfsafe.com, printed Aug. 2005, 2 pages.
 Unknown, "EMF Shielding & Conductive Fabrics", www.lessemf.com/fabric.html, The EMF Safety Superstore, Aug. 4, 2005, 12 pages.
 Yu, Roger, "Electronic Passports Set to Thwart Forgers", USA Today, Aug. 8, 2005, 4 pages.
 Schneier, Bruce, "Schneier on Security, A Weblog Covering Security and Secure Technology" Nov. 3, 2005, 18 pages.
 Schneier, Bruce, "Schneier on Security, A Weblog Covering Security and Secure Technology" Aug. 9, 2005, 19 pages.
 Unknown, "Foiling the Oyster Card", Spy Blog, Feb. 16, 2004, 5 pages.
 Unknown, www.WalletGard.com/contact.html, Protect Yourself Against Identity Theft, Revised Feb. 19, 2006, 2 pages.
 U.S. Appl. No. 11/350,309, filed Feb. 27, 2006, Colby, Steven M., Non-Final Office Action Issued Feb. 19, 2008, 5 pages.
 U.S. Appl. No. 11/350,309, filed Feb. 27, 2006, Colby, Steven M., Non-Final Office Action Issued Jan. 12, 2009, 14 pages.
 U.S. Appl. No. 11/350,309, filed Feb. 27, 2006, Colby, Steven M., Final Office Action Issued Sep. 23, 2009, 15 pages.
 U.S. Appl. No. 11/350,309, filed Feb. 27, 2006, Colby, Steven M., Notice of Allowance and Allowability, Issued Jan. 11, 2010.
 U.S. Appl. No. 12/777,474, filed May 11, 2010, Colby, Steven M., Non-Final Office Action issued Feb. 18, 2011, 7 pages.
 U.S. Appl. No. 12/777,474, filed May 11, 2010, Colby, Steven M., Non-Final Office Action issued Dec. 28, 2011, 13 pages.
 U.S. Appl. No. 12/777,474, filed May 11, 2010, Colby, Steven M., Non-Final Office Action issued Apr. 4, 2011, 9 pages.
 U.S. Appl. No. 11/420,721, filed May 26, 2006, Colby, Steven M., Non-Final Office Action issued Apr. 8, 2009, 18 pages.
 U.S. Appl. No. 11/468,026, filed Aug. 29, 2006, Colby, Steven M., Non-Final Office Action issued Apr. 10, 2009, 22 pages.
 U.S. Appl. No. 11/382,050, filed May 7, 2006, Colby, Steven M., Non-Final Office Action issued Apr. 8, 2009, 15 pages.
 U.S. Appl. No. 11/382,052, filed May 7, 2006, Colby, Steven M., Non-Final Office Action issued Apr. 8, 2009, 18 pages.
 U.S. Appl. No. 11/382,265, filed May 8, 2006, Colby, Steven M., Non-Final Office Action issued Apr. 10, 2009, 16 pages.
 U.S. Appl. No. 11/382,054, filed May 8, 2006, Colby, Steven M., Non-Final Office Action issued Apr. 10, 2009, 17 pages.
 U.S. Appl. No. 11/382,053, filed May 7, 2006, Colby, Steven M., Non-Final Office Action issued Apr. 8, 2009, 19 pages.
 U.S. Appl. No. 12/577,209, filed Oct. 12, 2009, Colby, Steven M., Non-Final Office Action issued Mar. 21, 2012, 22 pages.
 U.S. Appl. No. 12/577,209, filed Oct. 12, 2009, Colby, Steven M., Final Rejection issued Aug. 10, 2012, 24 pages.
 Hornyak, Tim, "RFID Powder", Scientific American, Feb. 2008, pp. 68-71.
 PCT/99/21073, International Search Report dated Dec. 2, 1999, 3 pages.
 U.S. Appl. No. 11/458,620, filed Jul. 19, 2006, Colby, Steven M., Non-Final Office Action issued Jun. 24, 2010, 6 pages.
 U.S. Appl. No. 11/458,620, filed Jul. 19, 2006, Colby, Steven M., Non-Final Office Action issued Mar. 30, 2009, 19 pages.
 U.S. Appl. No. 11/458,620, filed Jul. 19, 2006, Colby, Steven M., Non-Final Office Action issued Dec. 14, 2009, 23 pages.
 Deutschbein, Carlos Vila, "Digital Frequency Shifting for Electroacoustic Feedback Suppression", in Audio Engineering Society Convention Paper, Presented at the 118th Convention, May 28-31, 2005, Barcelona, Spain.
 English translation of JP11348471A.
 Leach, "Passports go electronic with new microchip", The Christian Science Monitor, Dec. 9, 2004, 6 pages.
 Schimke, et al., "Security analysis for biometric data in ID documents", SPIE.Digital Library, Mar. 31, 2005, 5 pages.
 Schimke, et al., "Security analysis for biometric data in ID documents", SPIE vol. 5681, Mar. 31, 2005, p. 474-485.
 E-Passport Mock Port of Entry Test, Nov. 29-Dec. 2, 2004, 150 pages.
 U.S. Appl. No. 13/084,433, filed Apr. 11, 2011, Colby, Steven M., Non-Final Office Action issued Sep. 9, 2013, 15 pages.
 U.S. Appl. No. 13/084,433, filed Apr. 11, 2011, Colby, Steven M., Final Rejection issued Jan. 2, 2014, 21 pages.
 U.S. Appl. No. 13/084,433, filed Apr. 11, 2011, Colby, Steven M., Non-Final Office Action issued Jun. 5, 2014, 21 pages.
 U.S. Appl. No. 13/084,433, filed Apr. 11, 2011, Colby, Steven M., Final Rejection issued Sep. 29, 2014, 19 pages.
 U.S. Appl. No. 60/671,790, Mahaffey, Kevin, Filed Apr. 14, 2005.

* cited by examiner

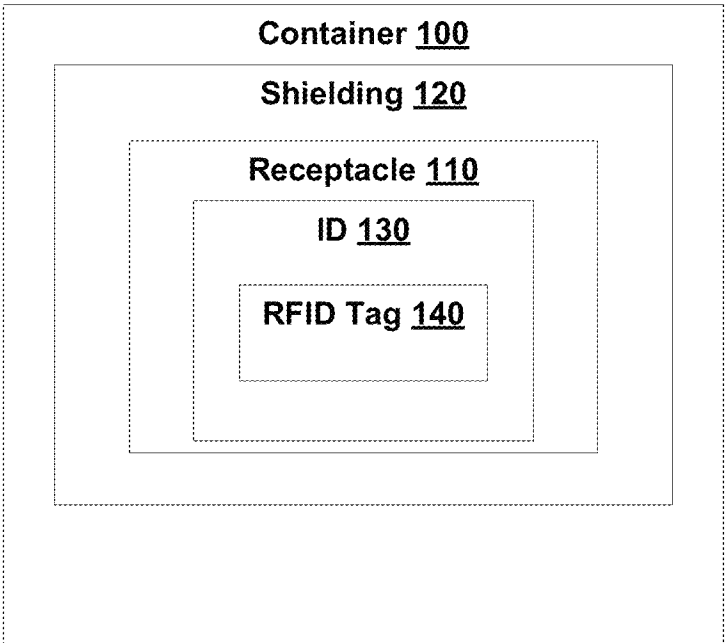

FIG. 1

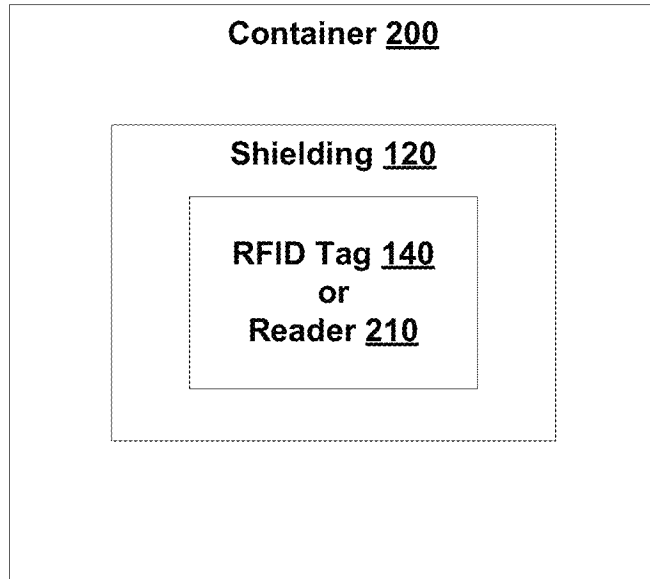

FIG. 2

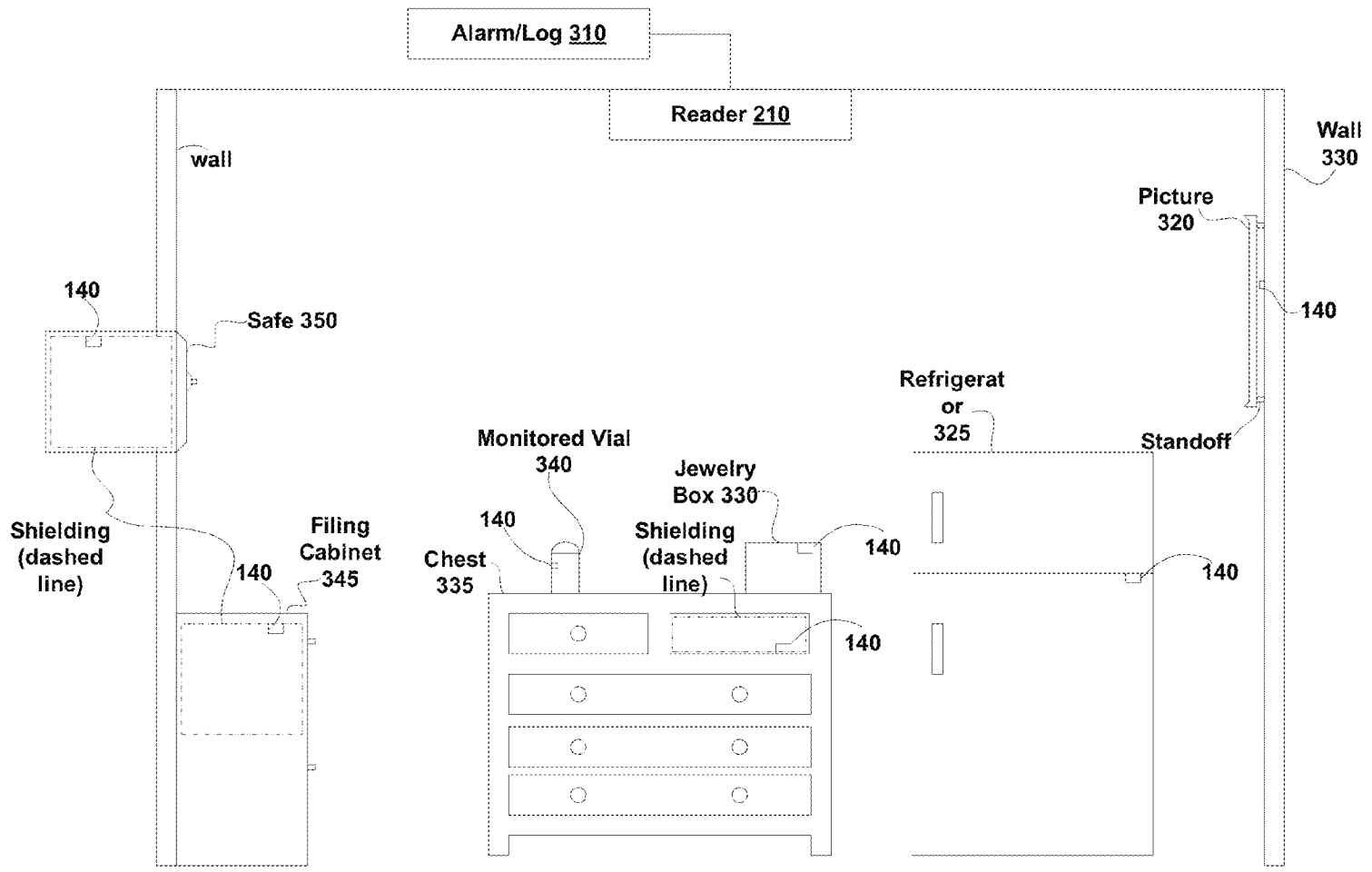

FIG. 3

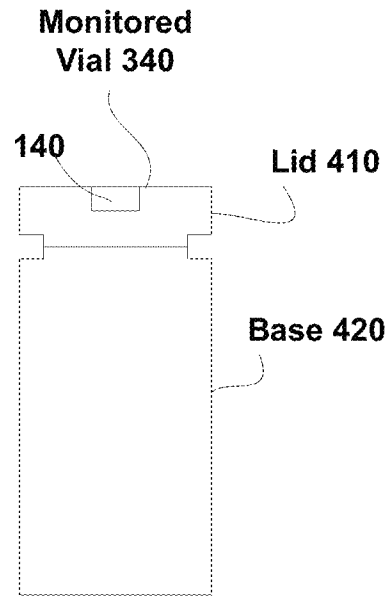

FIG. 4

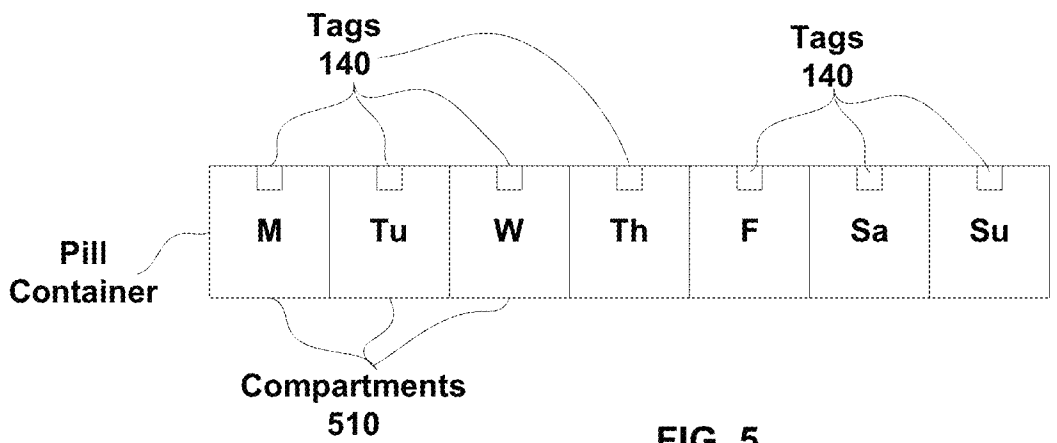

FIG. 5

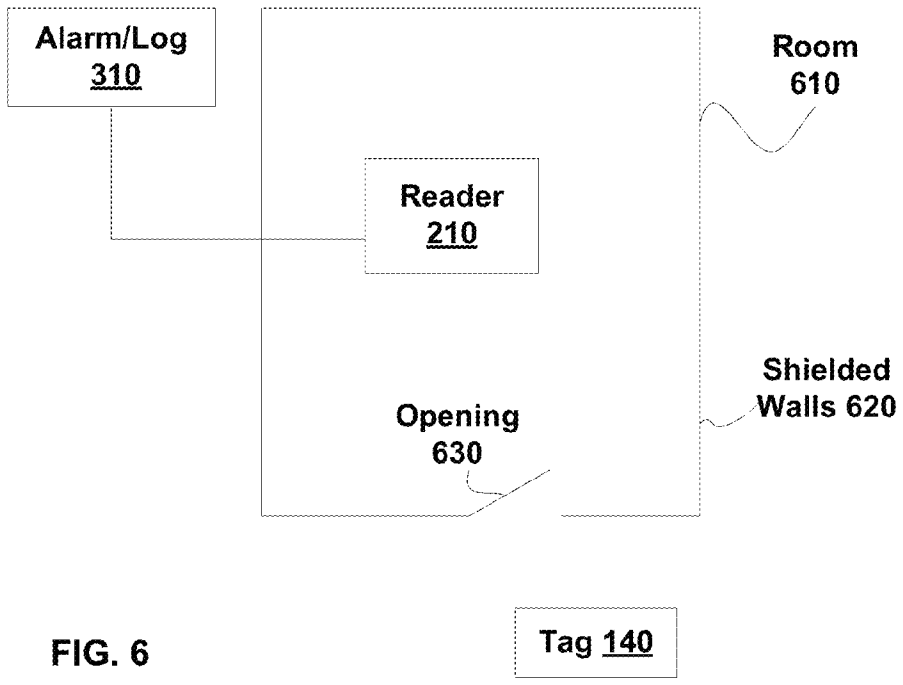

FIG. 6

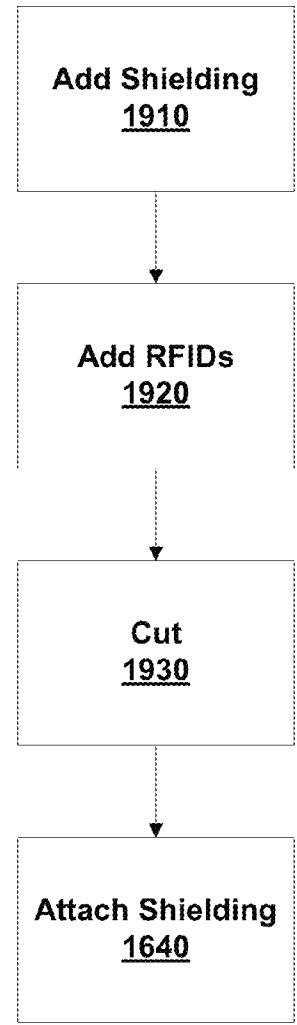

FIG. 19

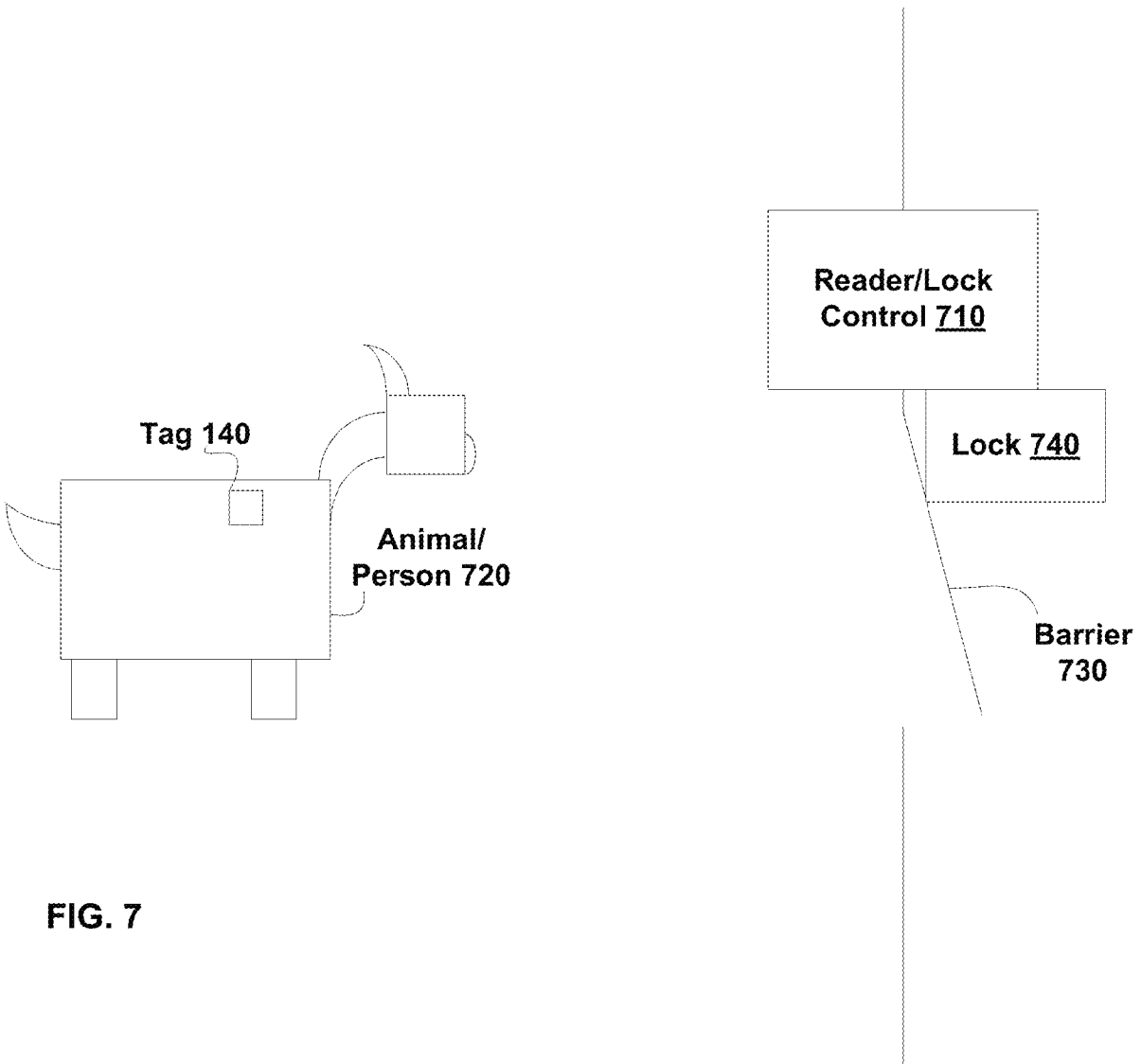

FIG. 7

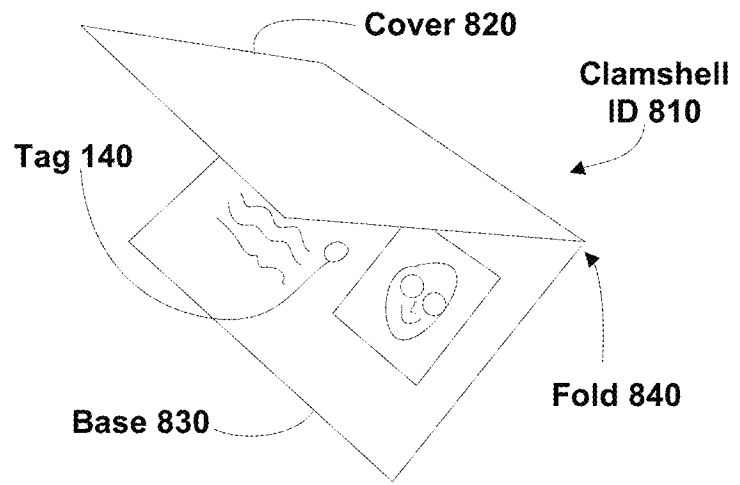

FIG. 8

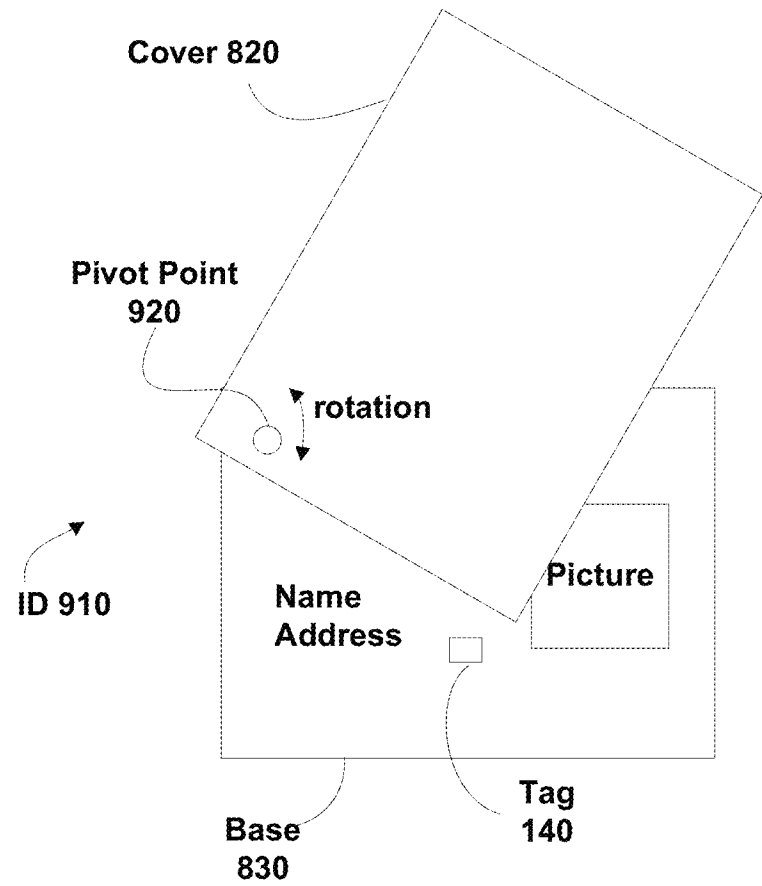

FIG. 9

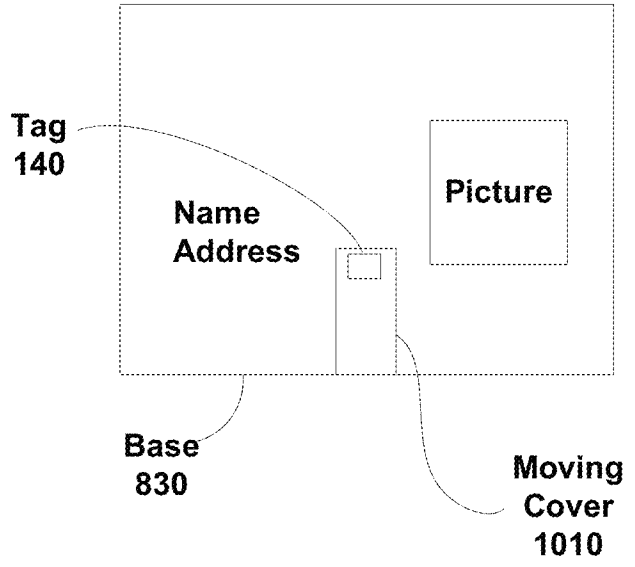

FIG. 10A

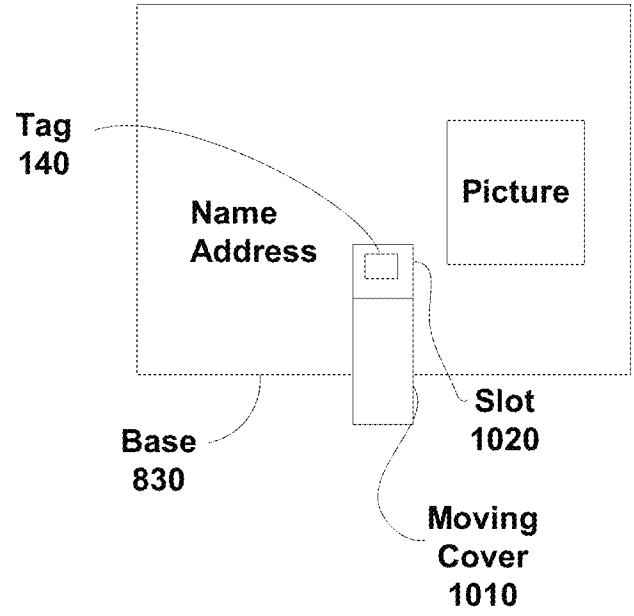

FIG. 10B

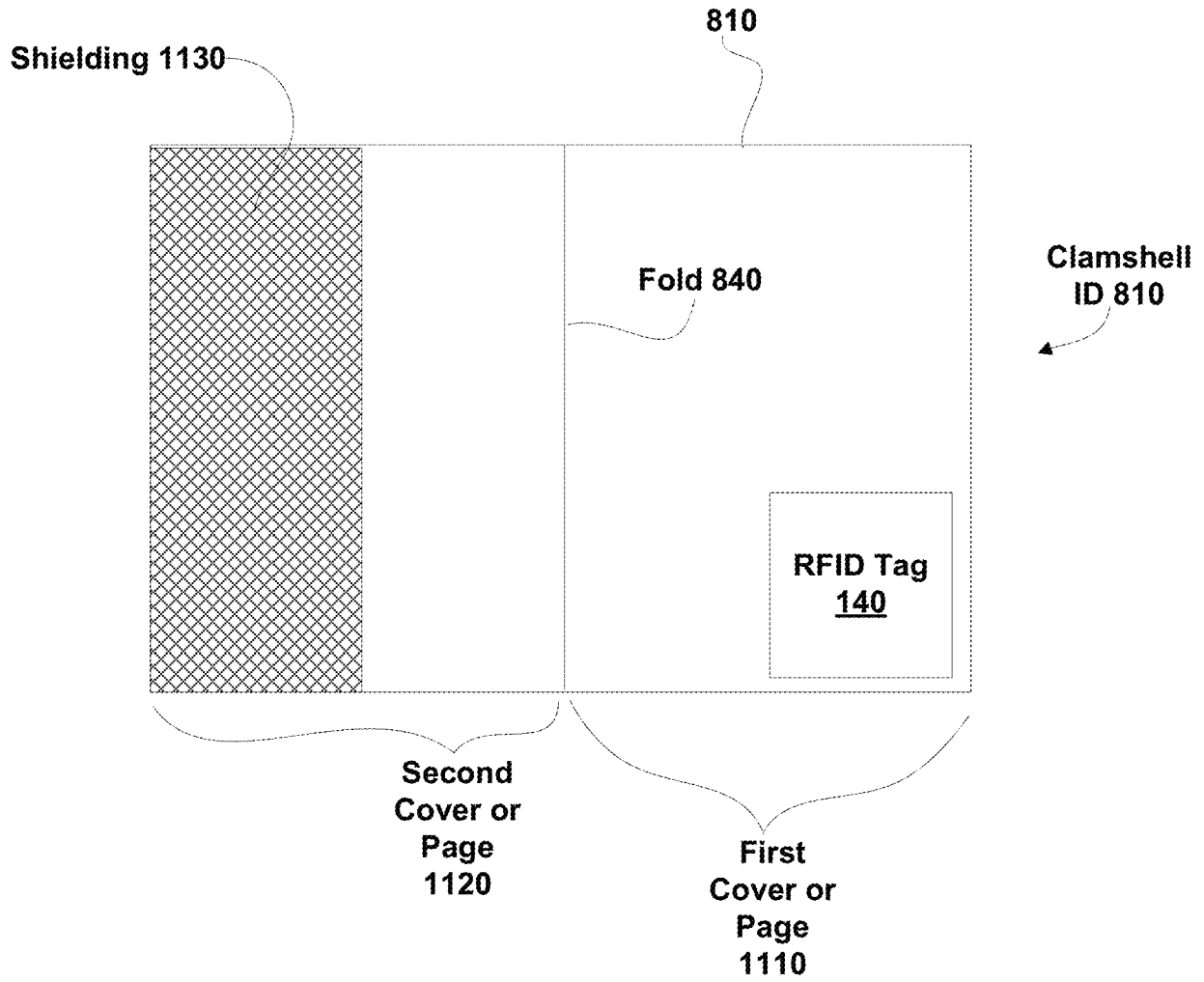

FIG. 11

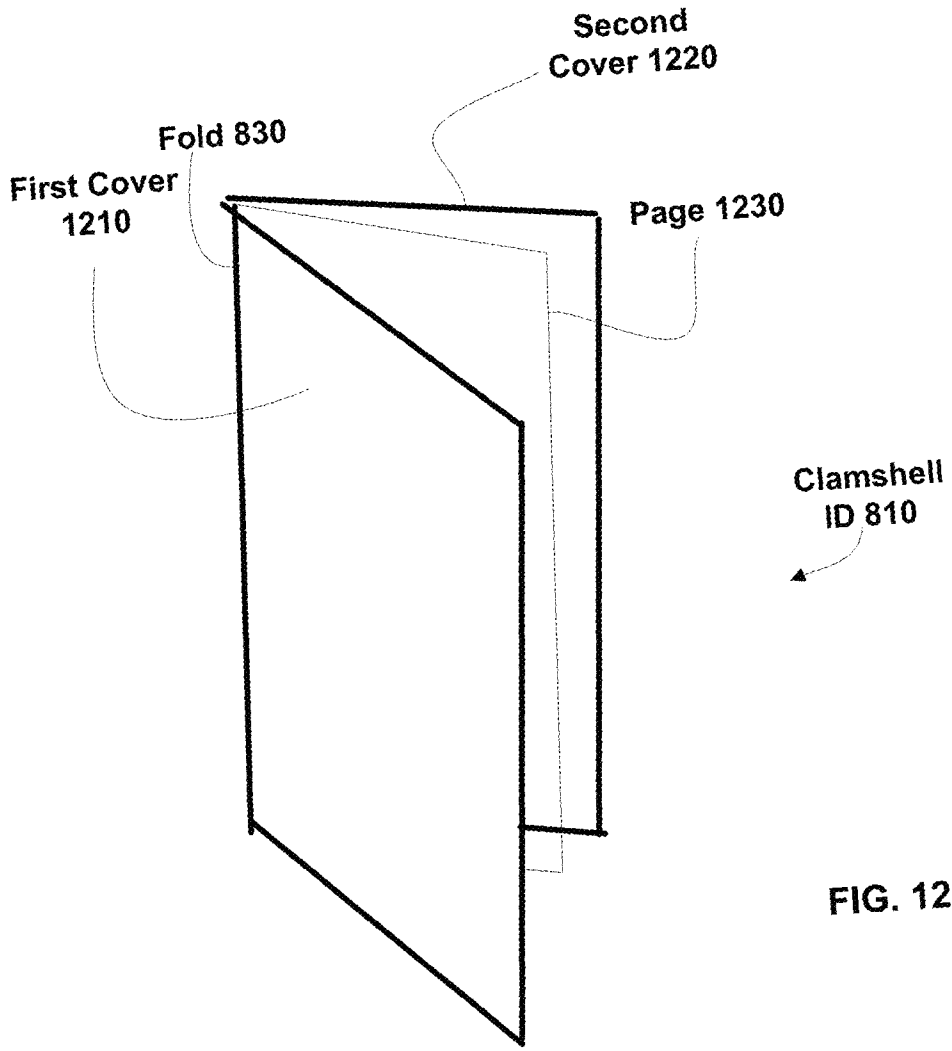

FIG. 12

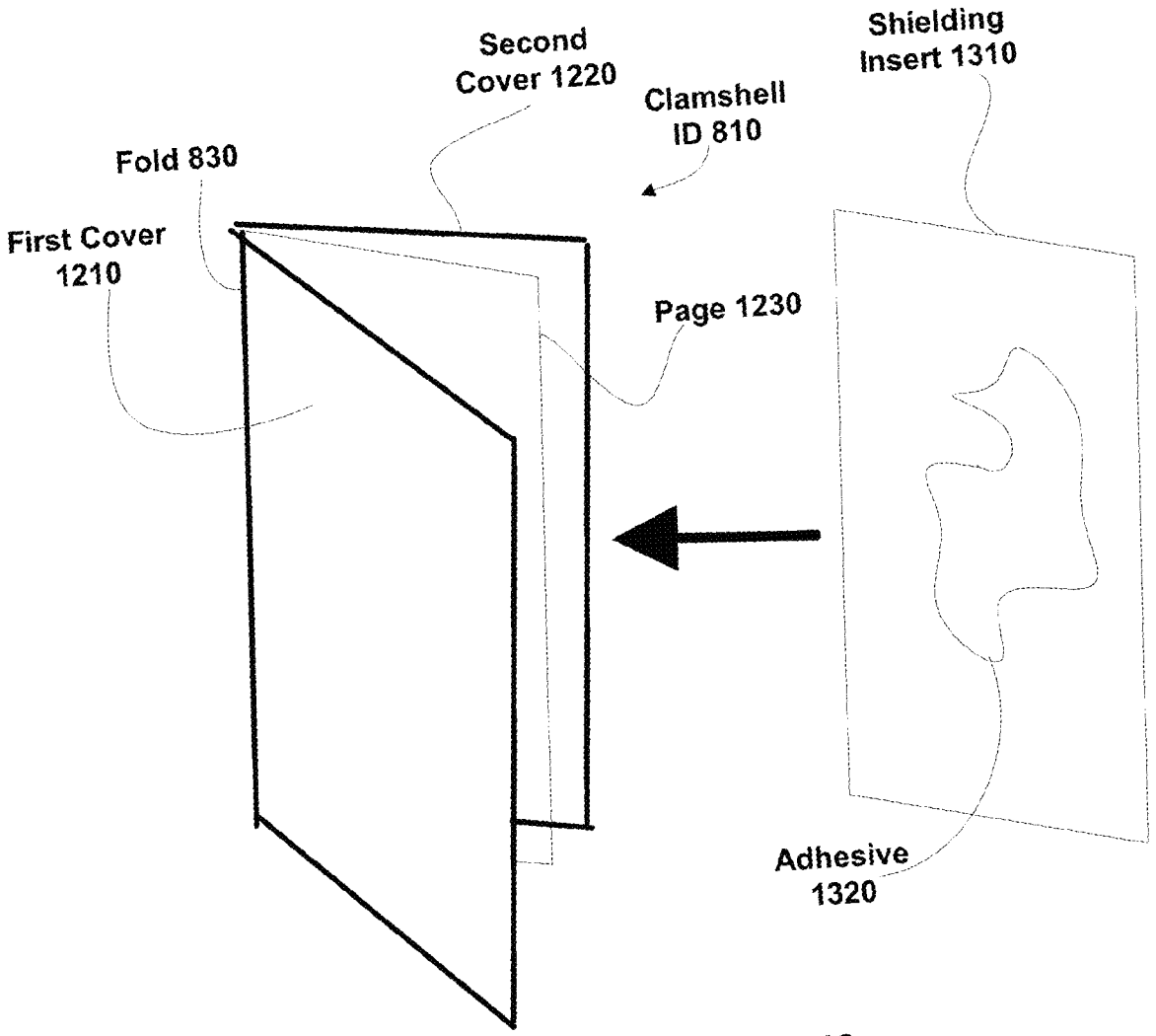

FIG. 13

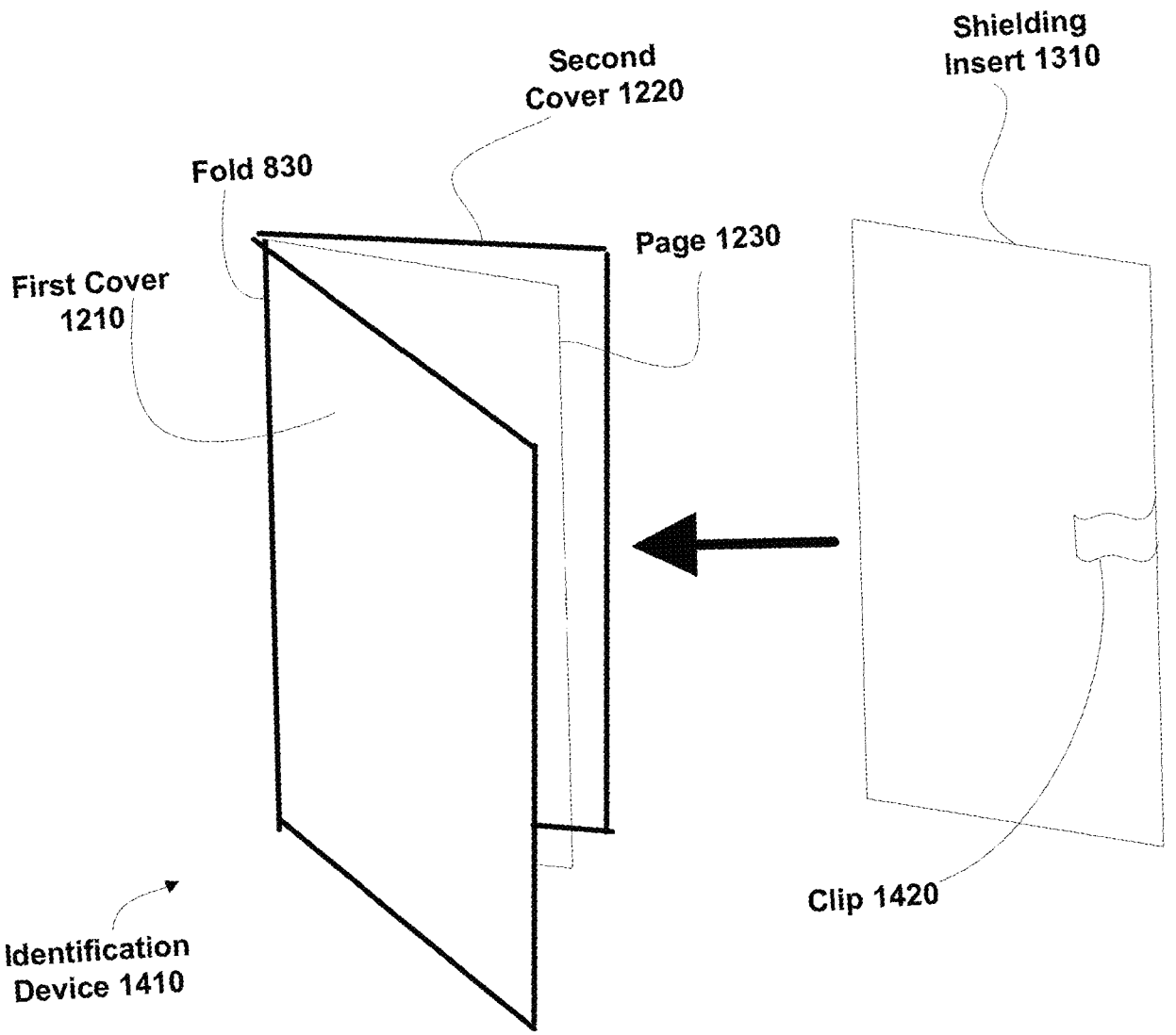

FIG. 14

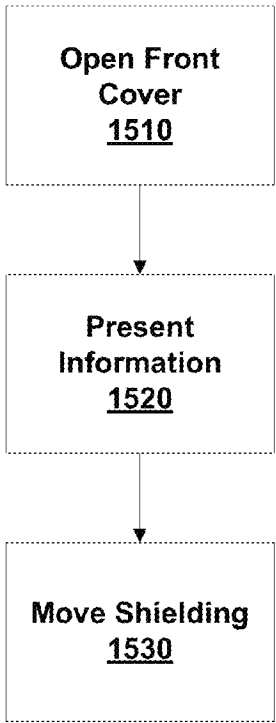

FIG. 15

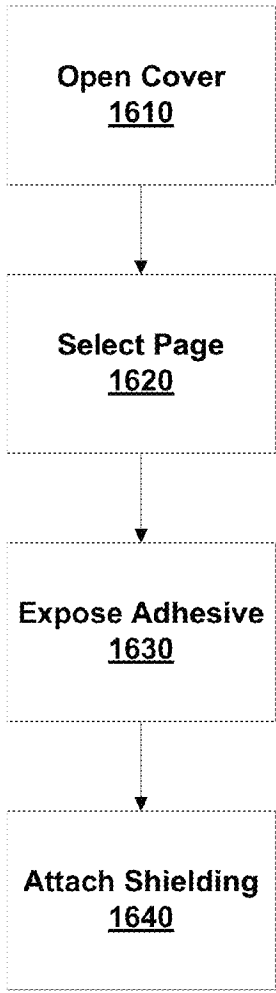

FIG. 16

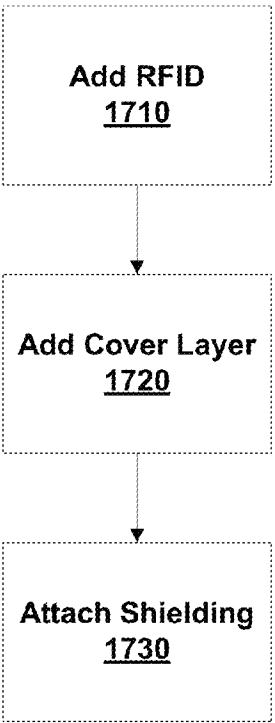

FIG. 17

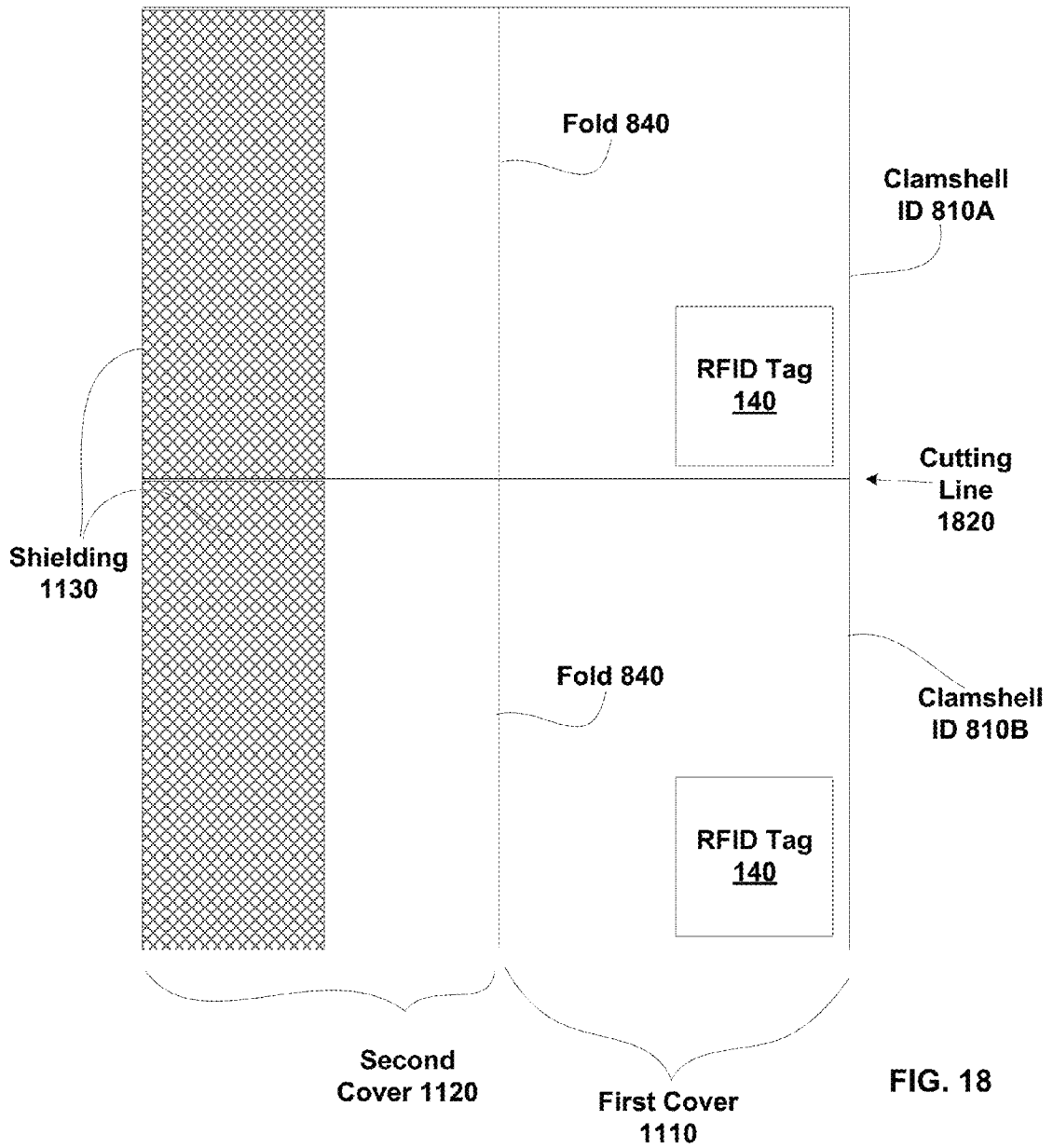



FIG. 20

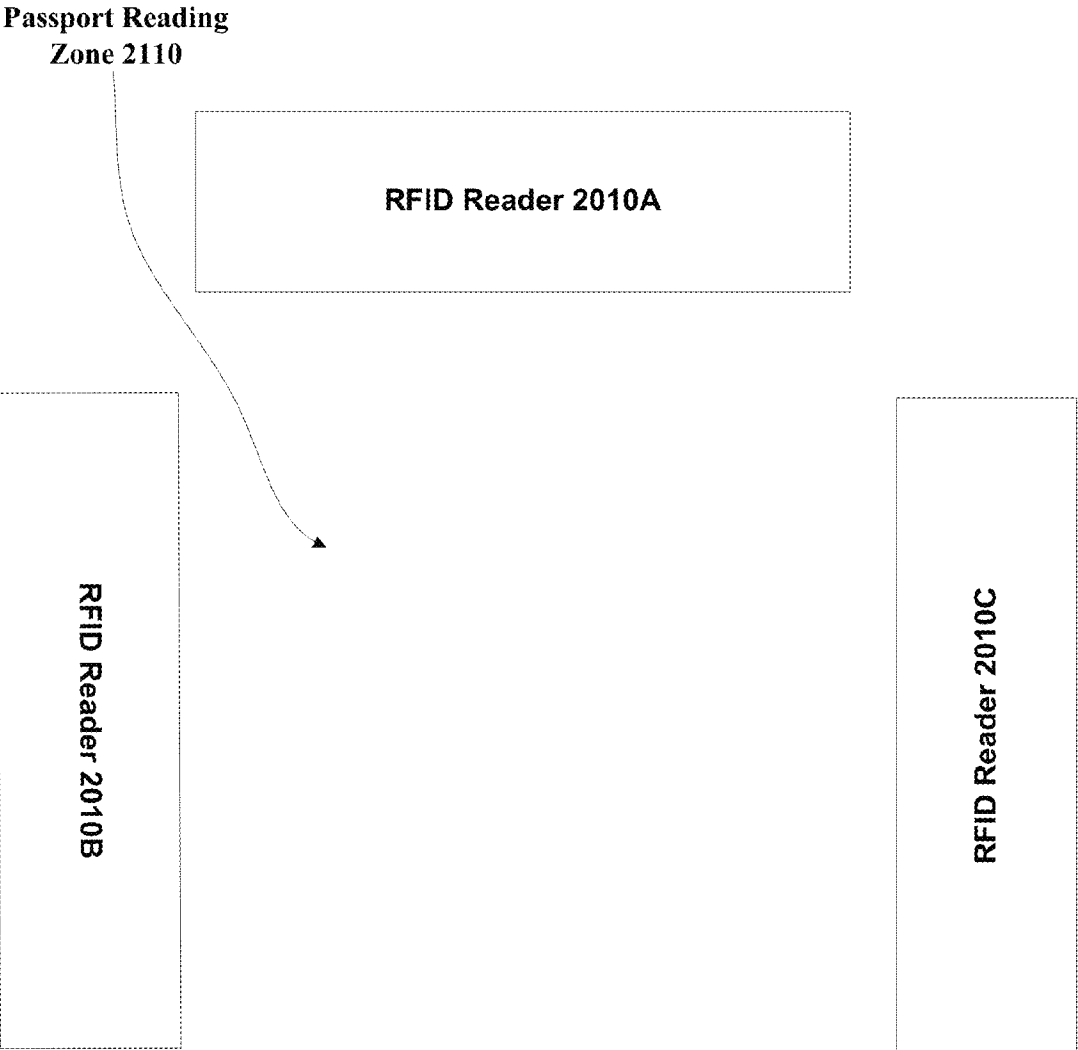

FIG. 21

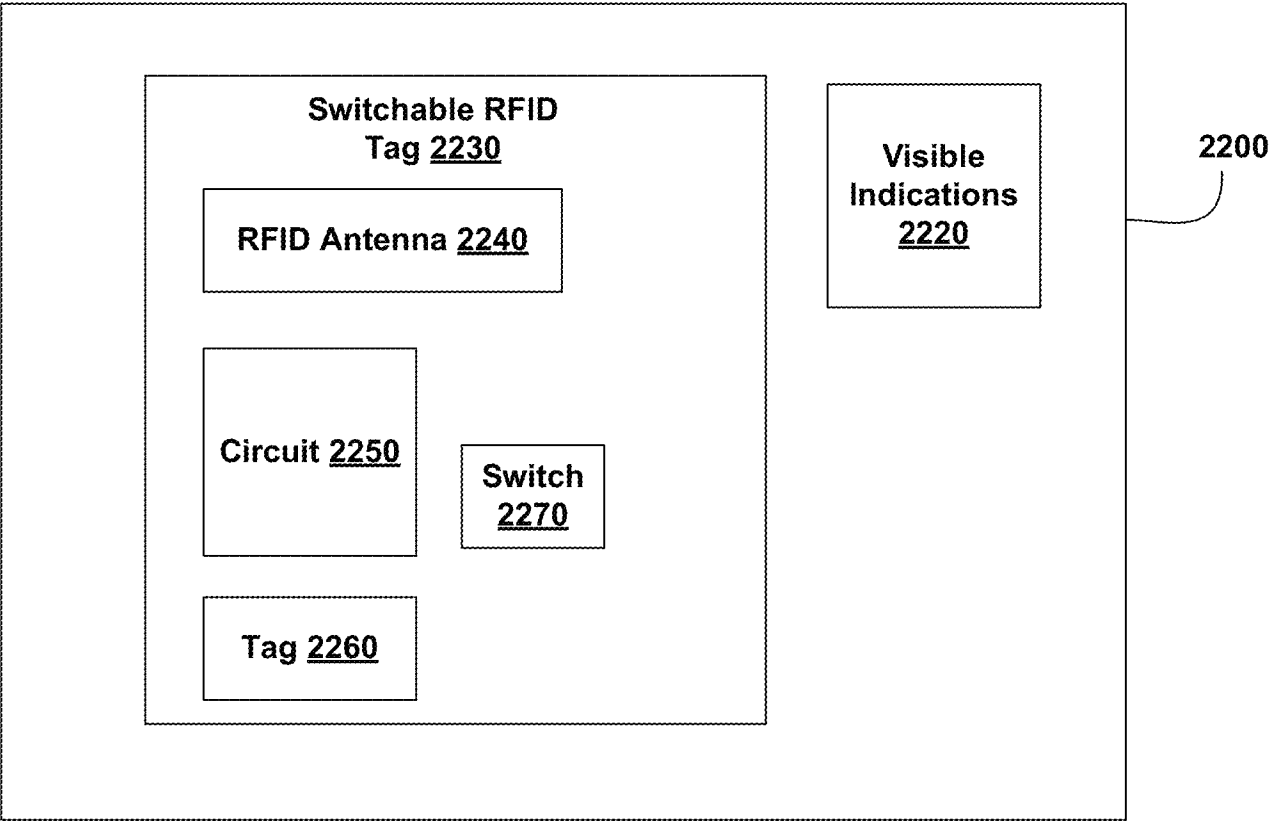

FIG. 22

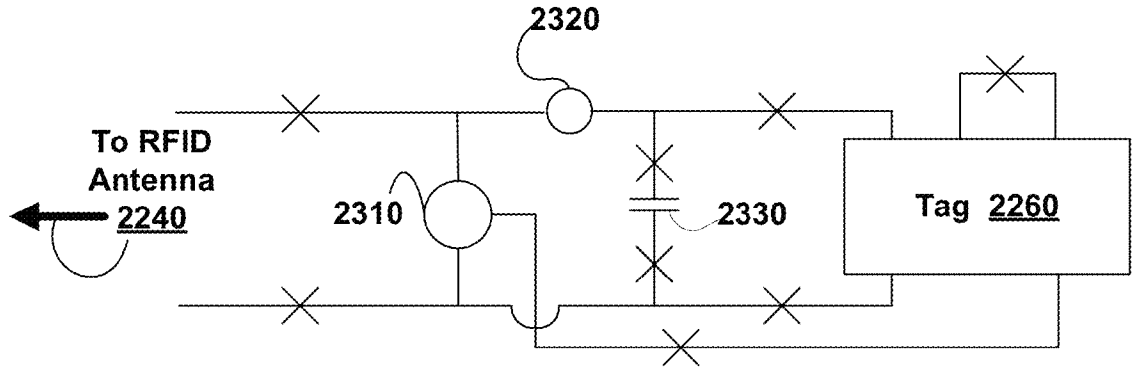

FIG. 23

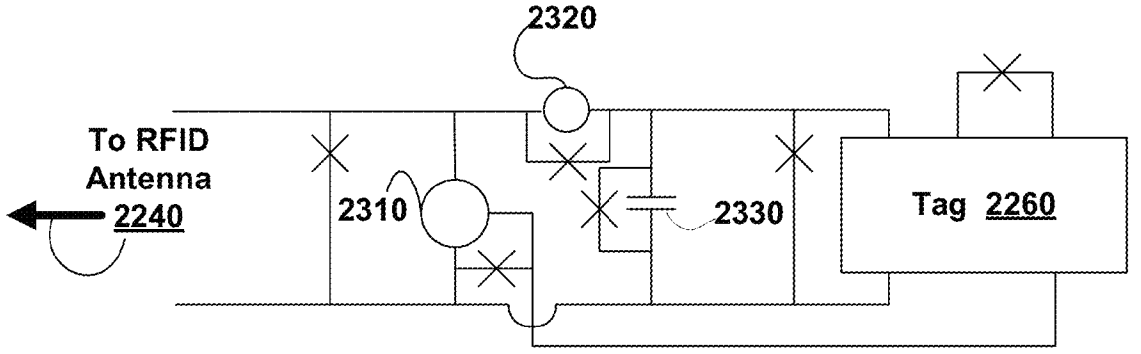
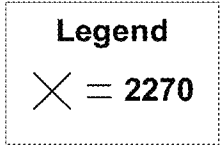
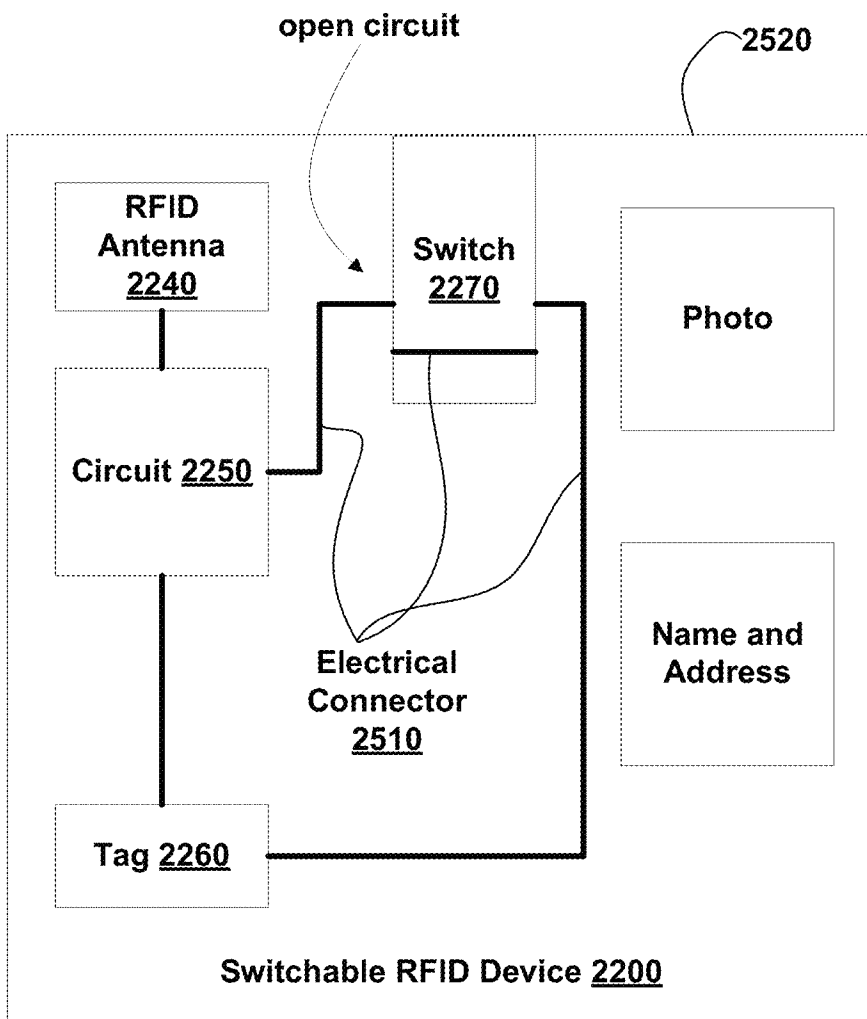

FIG. 24



OFF Position FIG. 25A

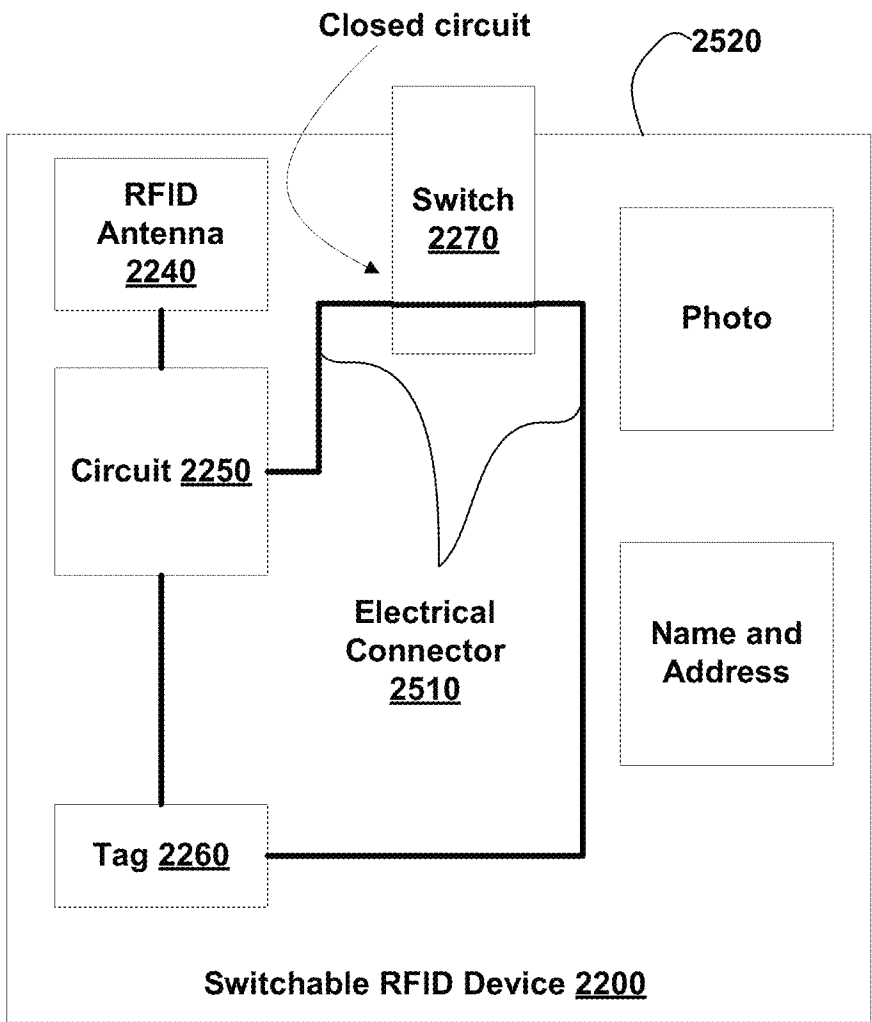

FIG. 25B ON Position

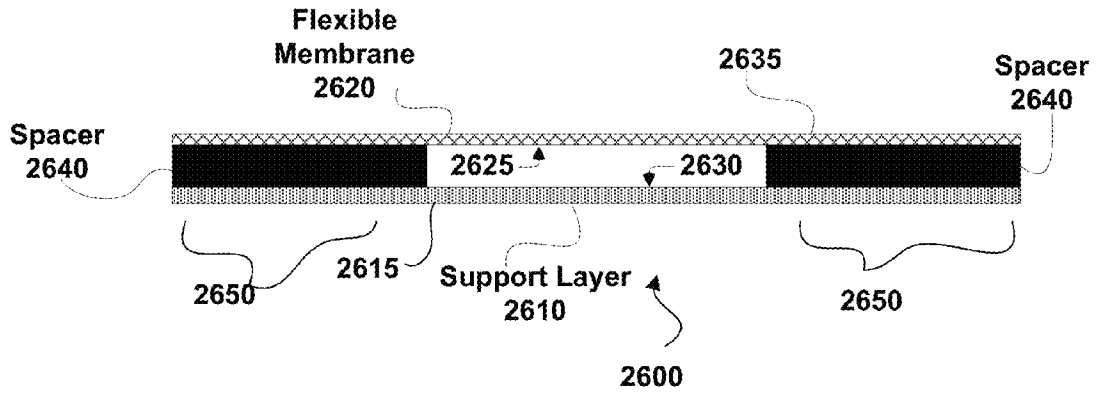

FIG. 26A
Membrane Switch (OFF)

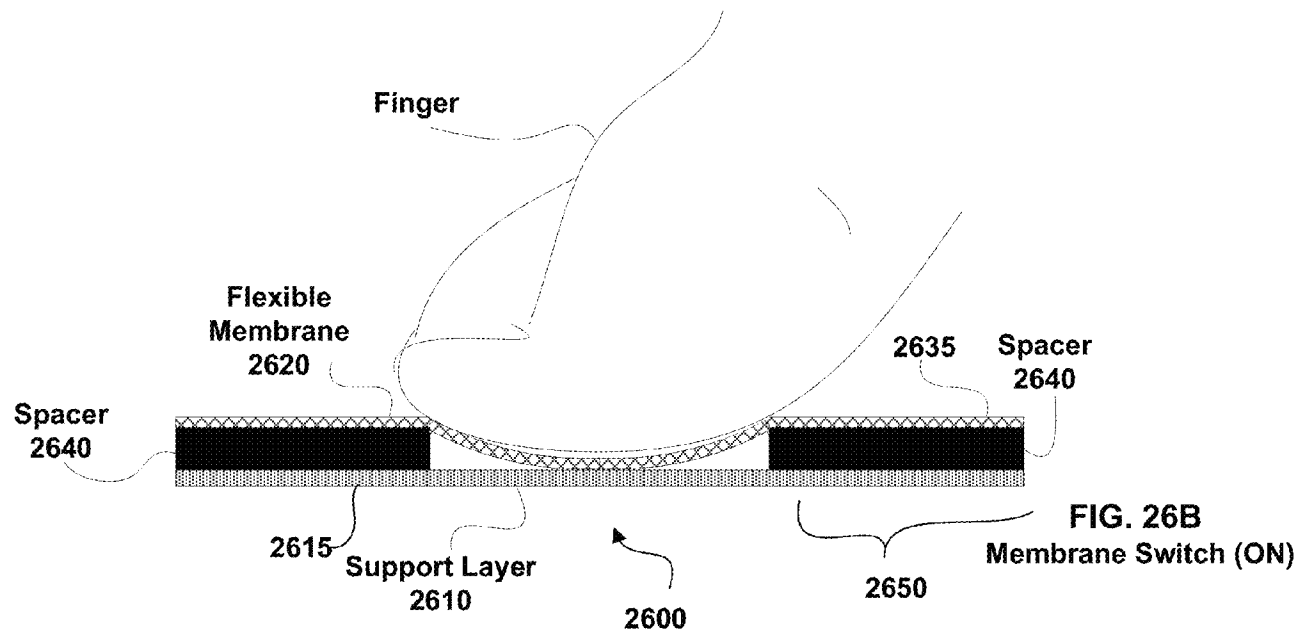
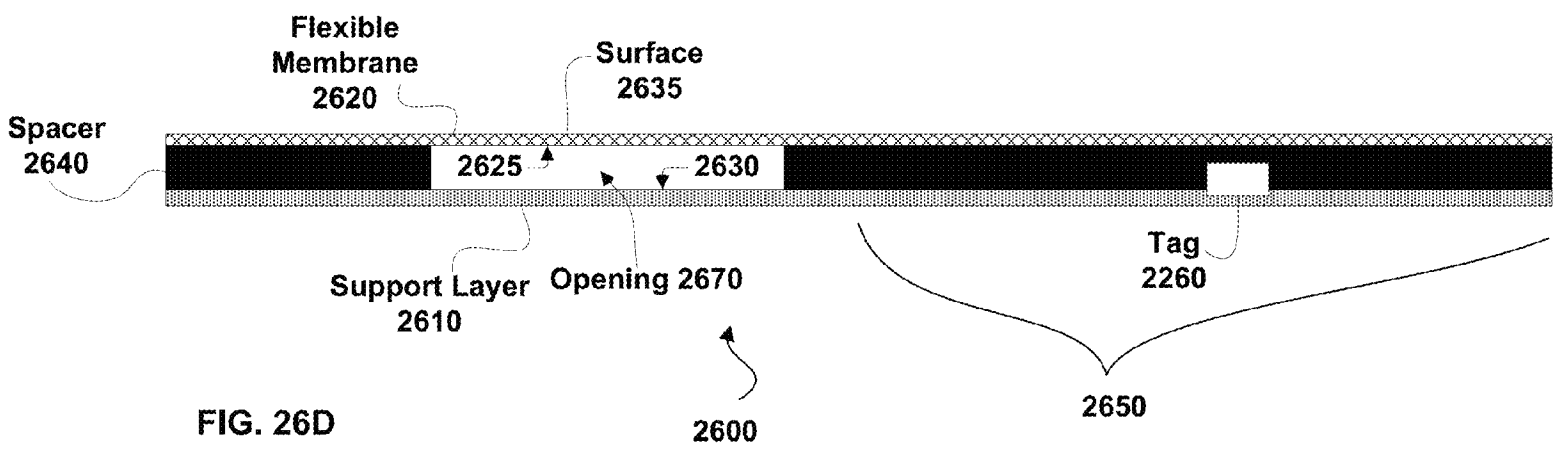
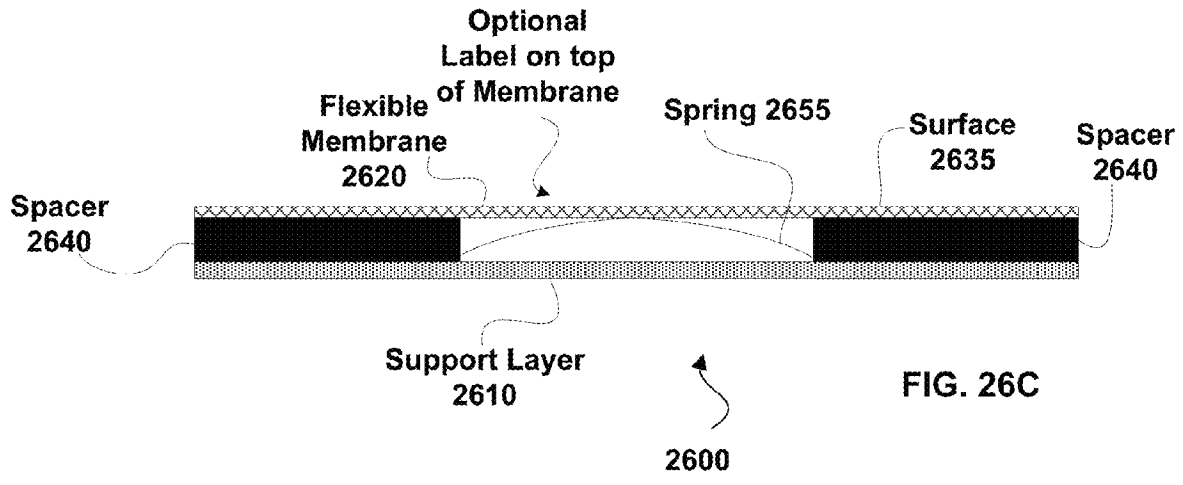

FIG. 26B
Membrane Switch (ON)



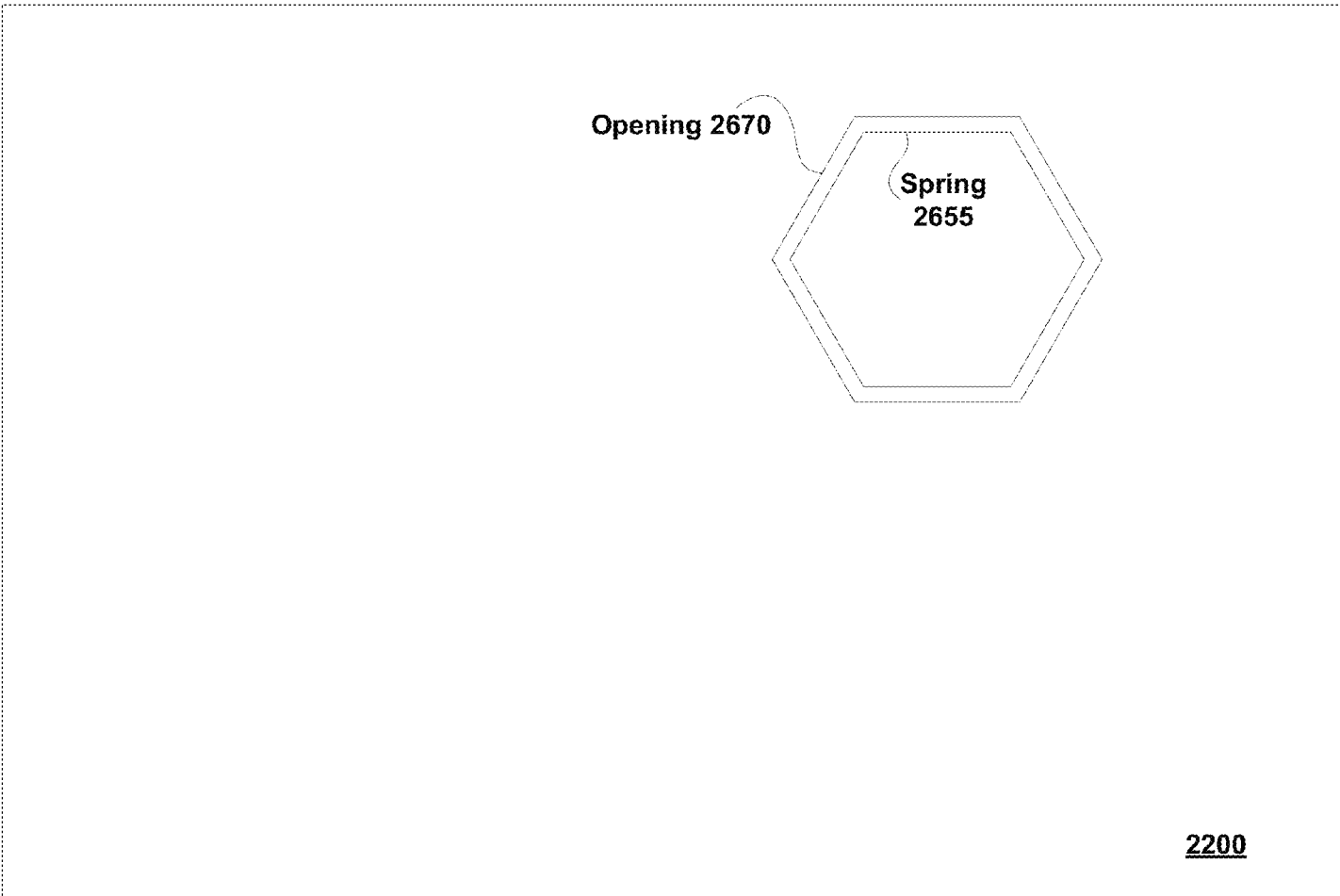

FIG. 27
(Top View)

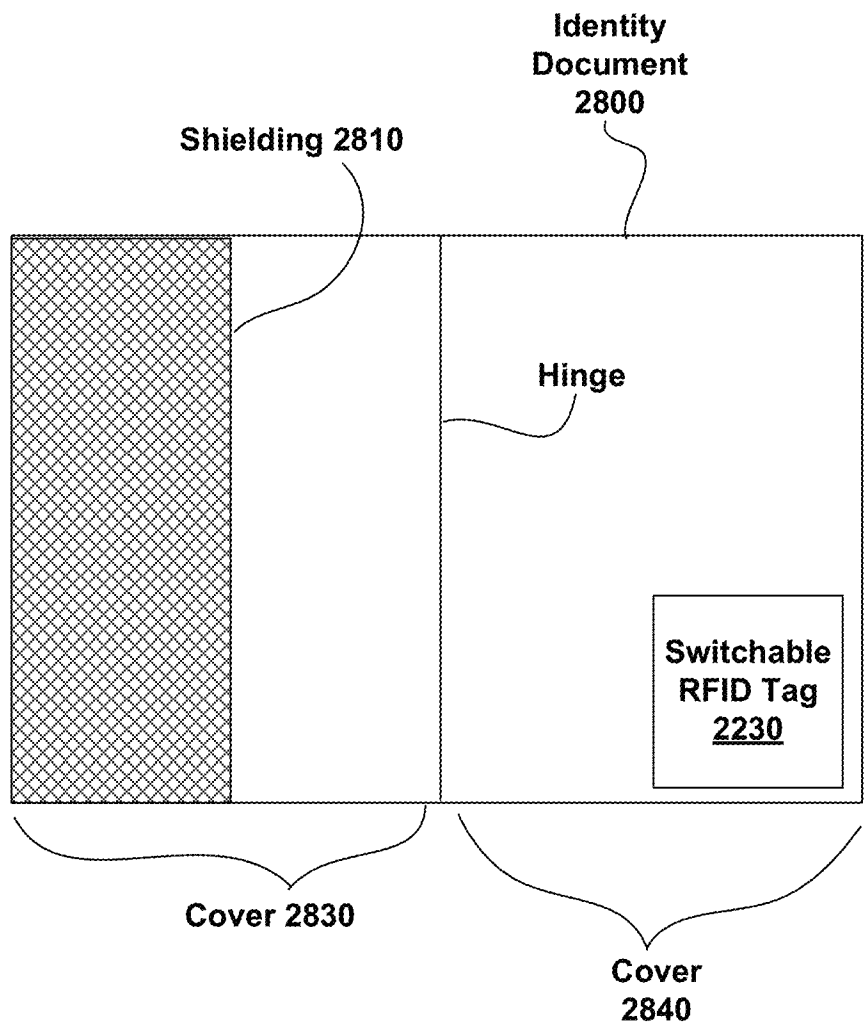

FIG. 28

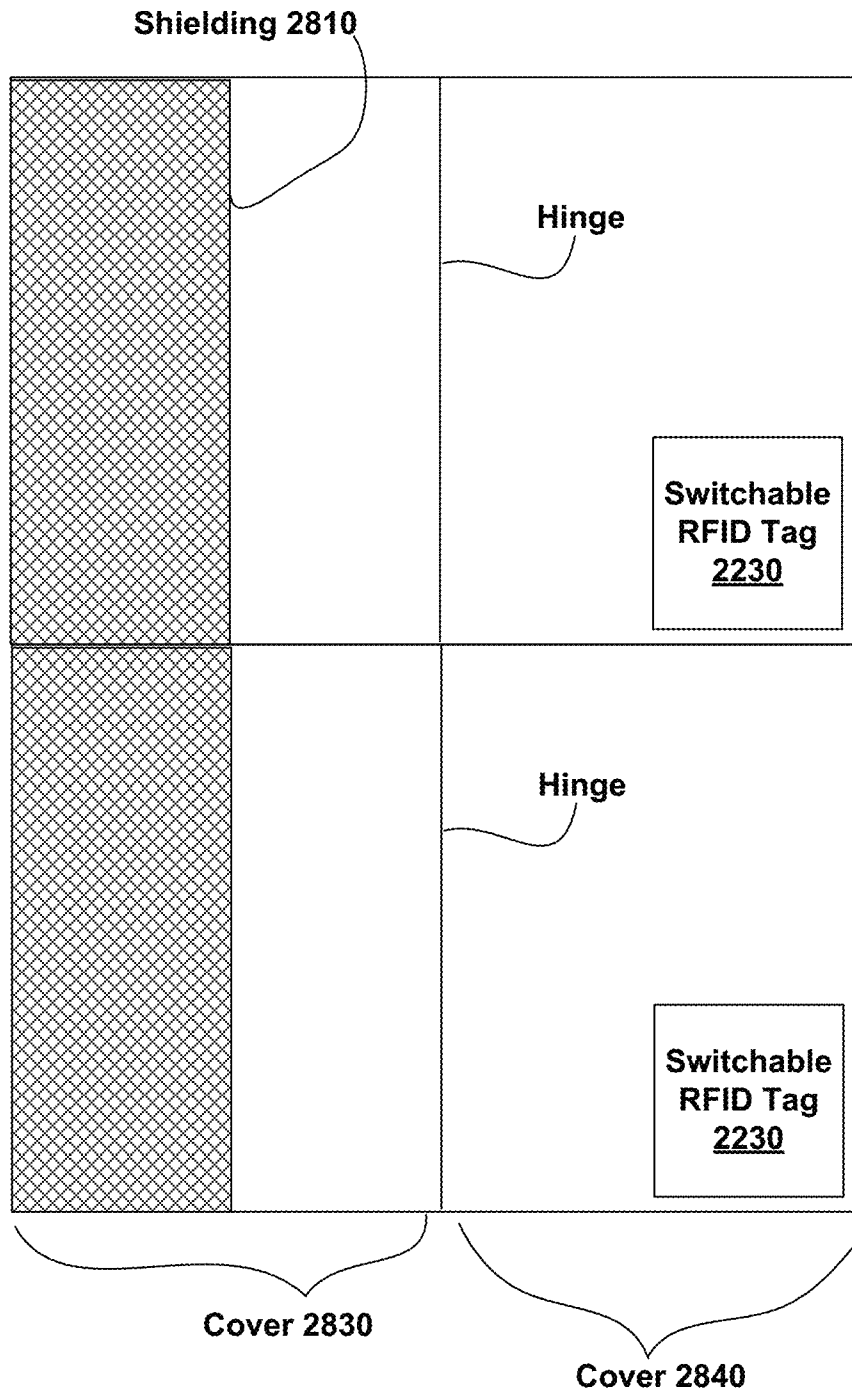

FIG. 29

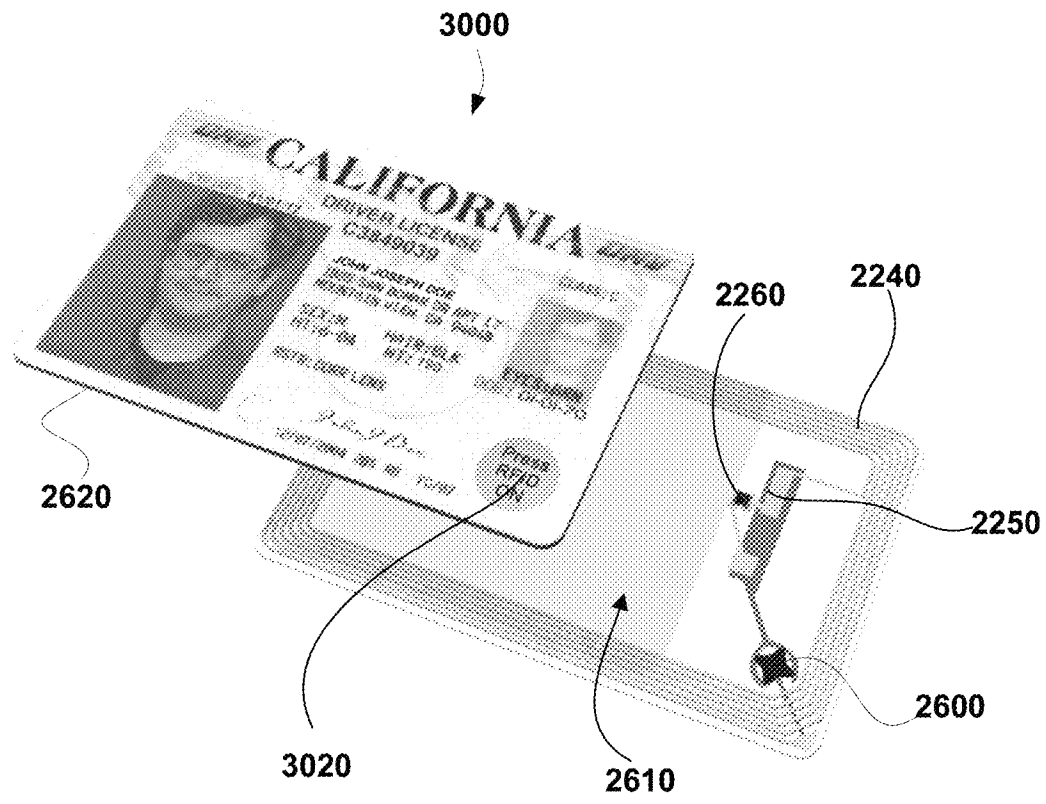

FIG. 30

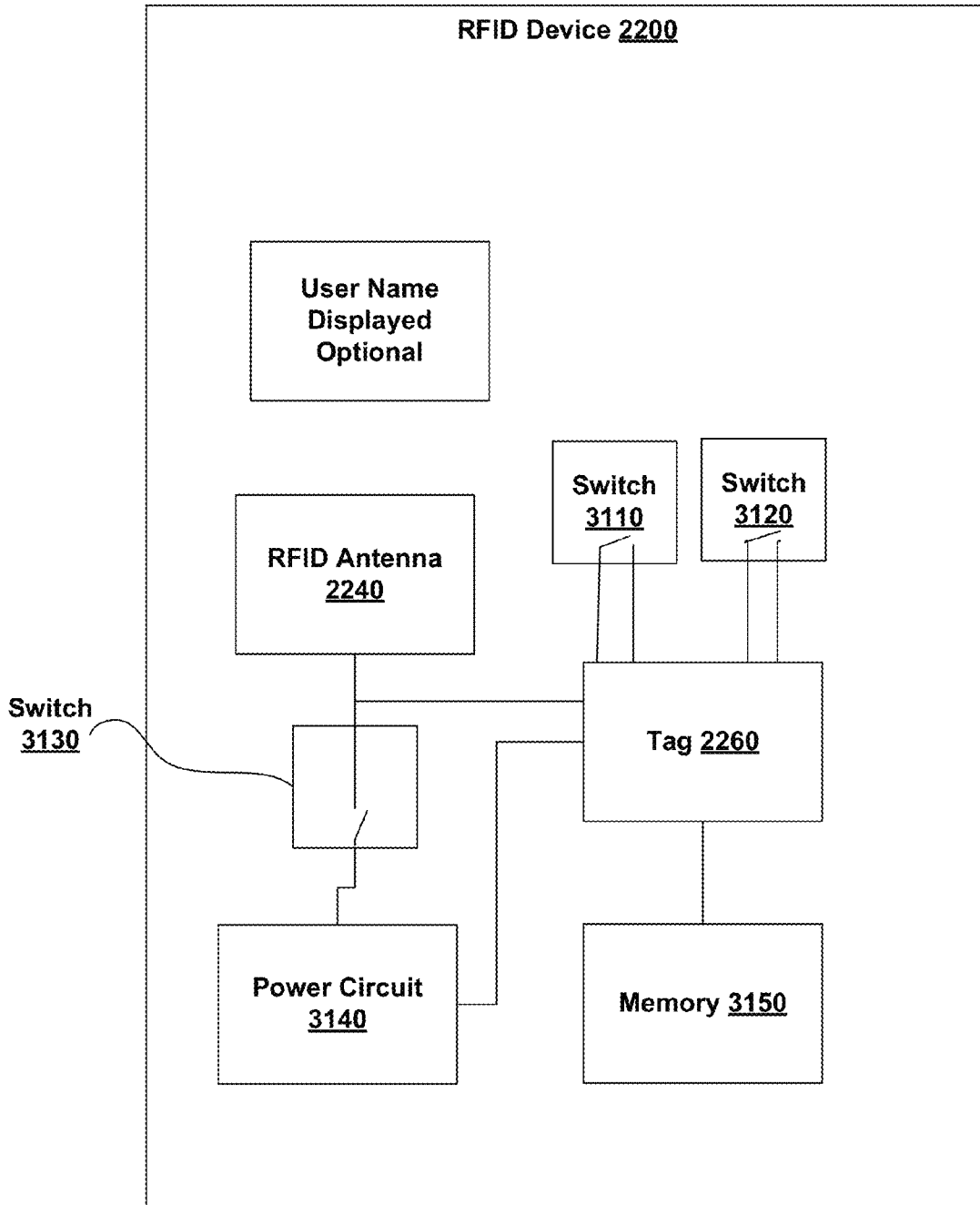

FIG. 31

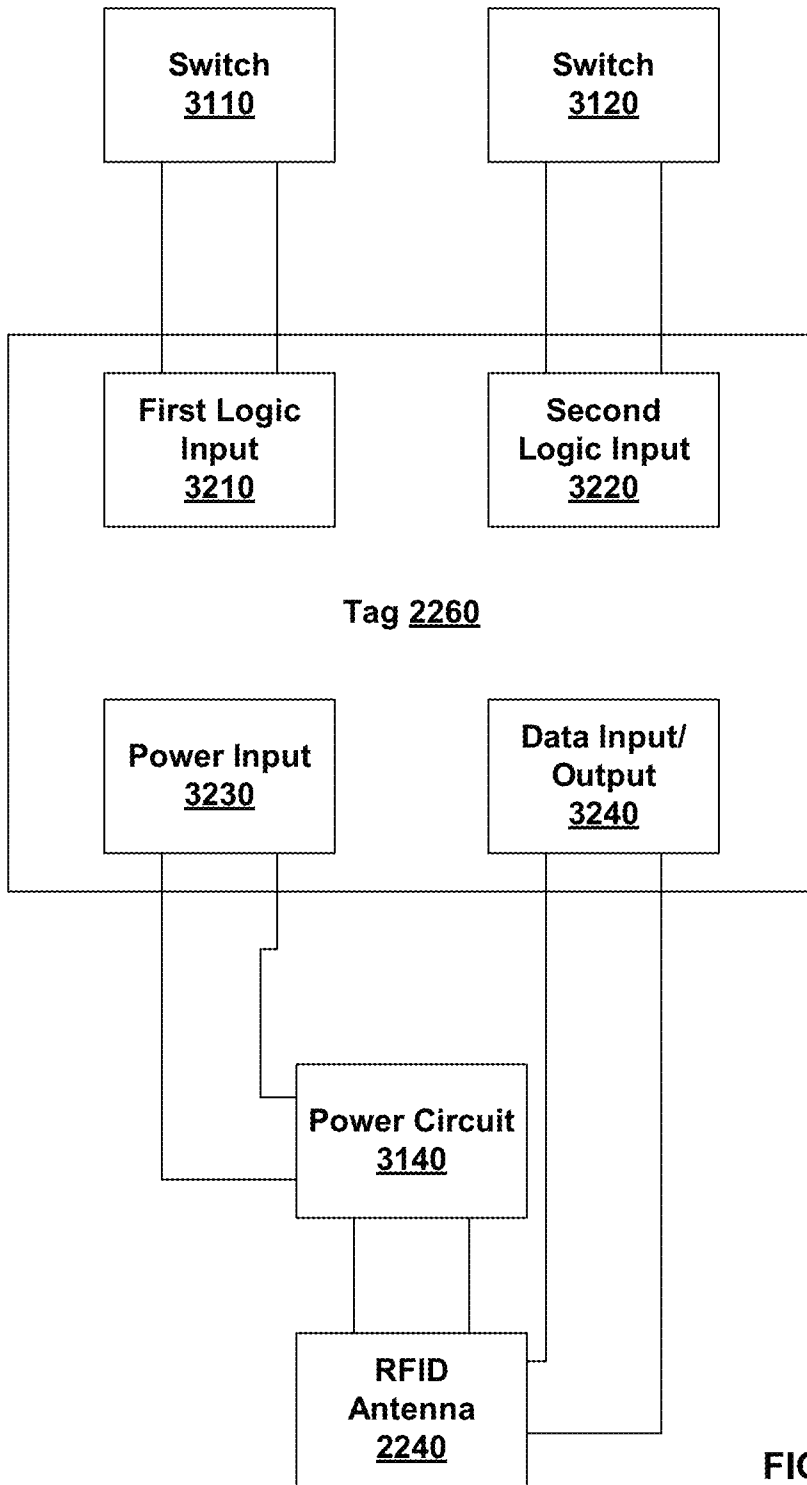

FIG. 32

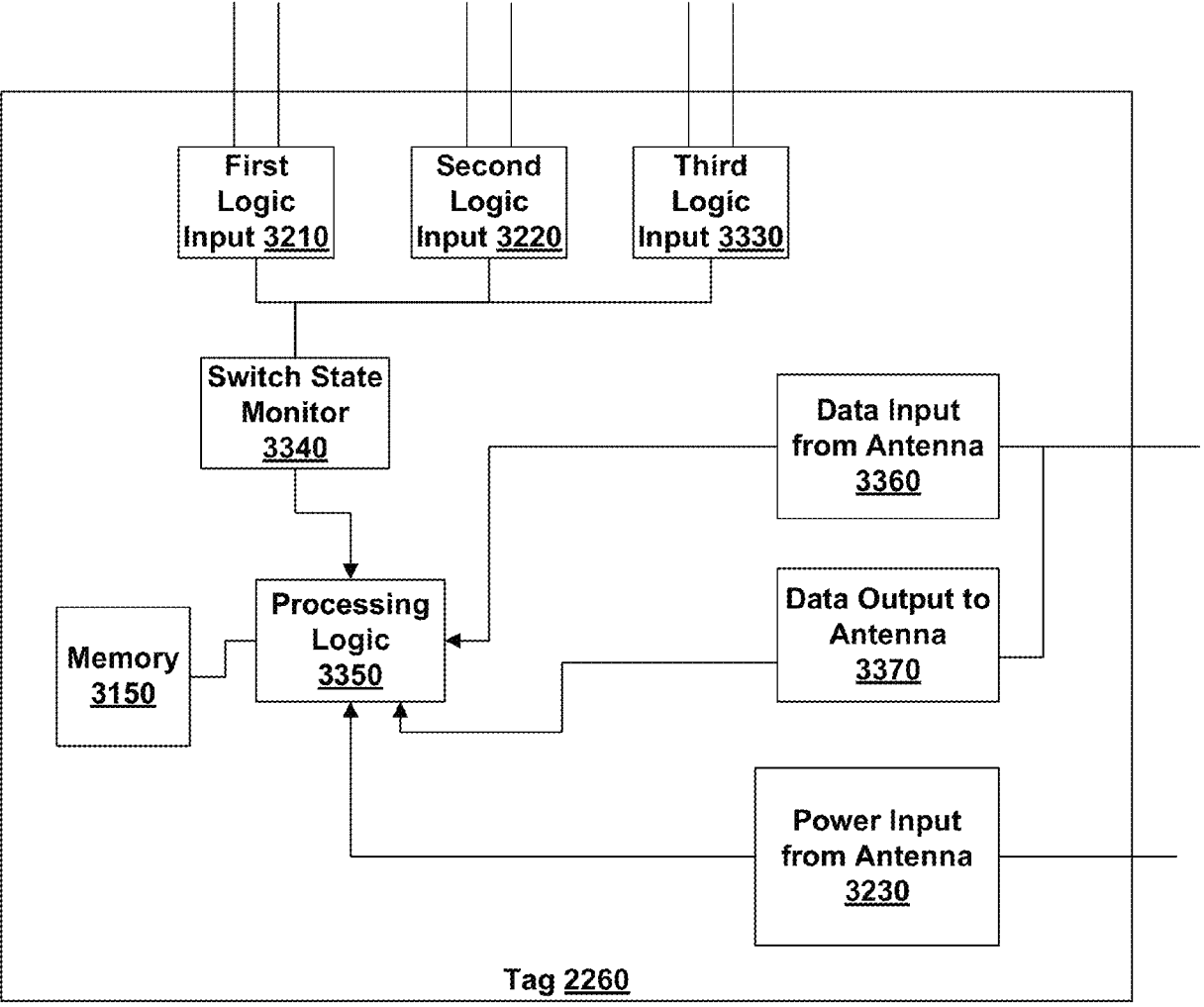

FIG. 33

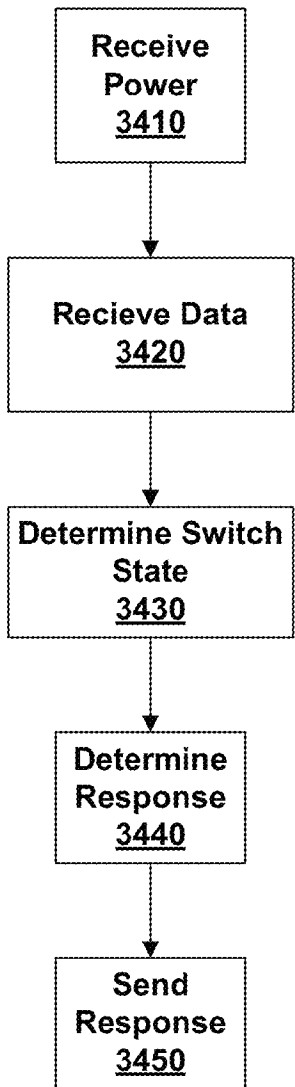

FIG. 34

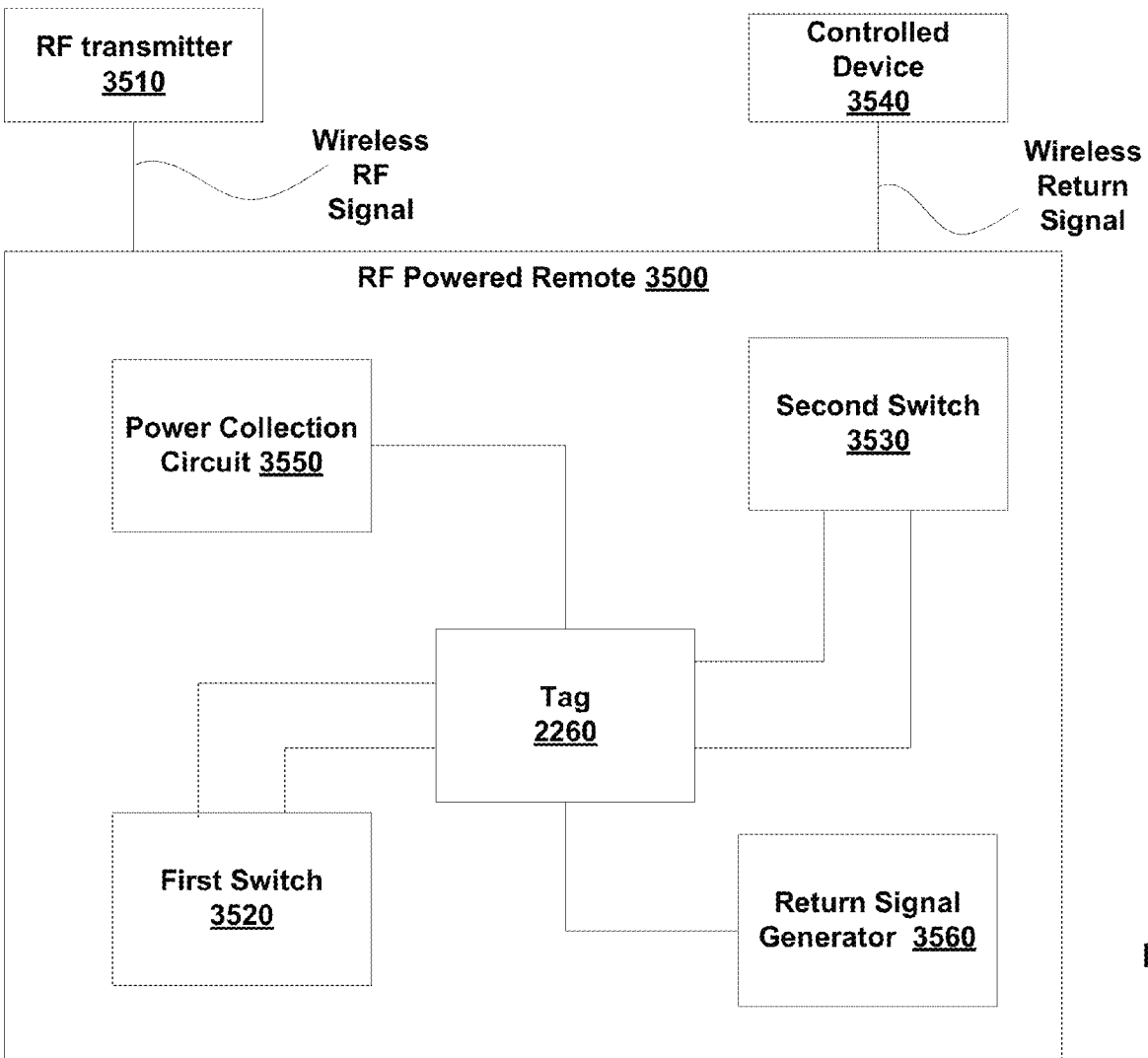

FIG. 35

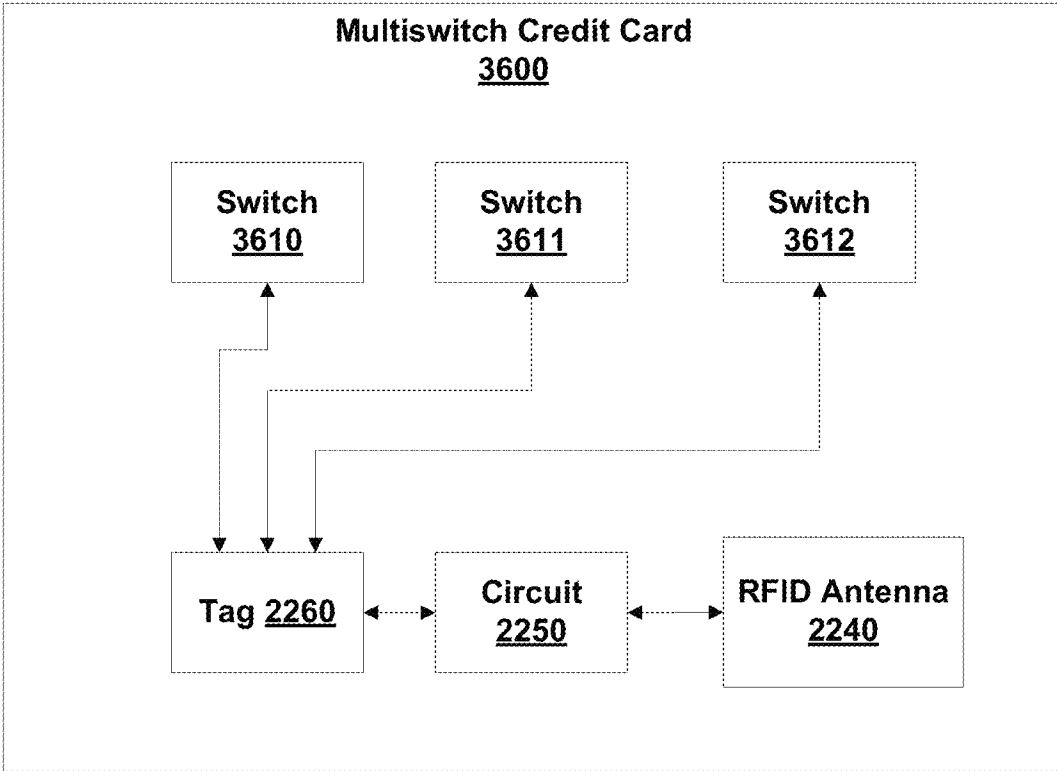

FIG. 36

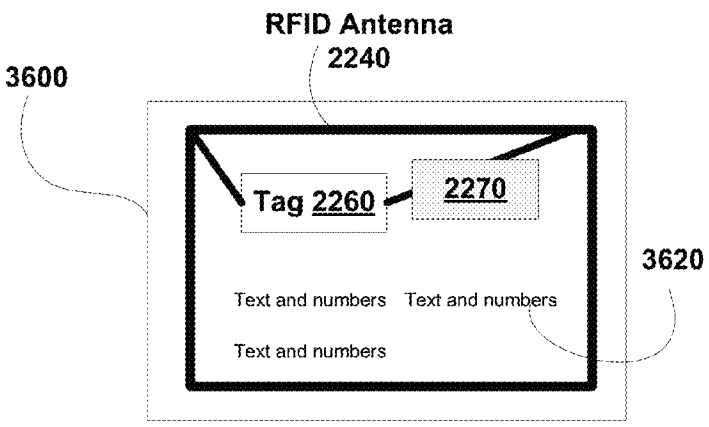

FIG. 37A

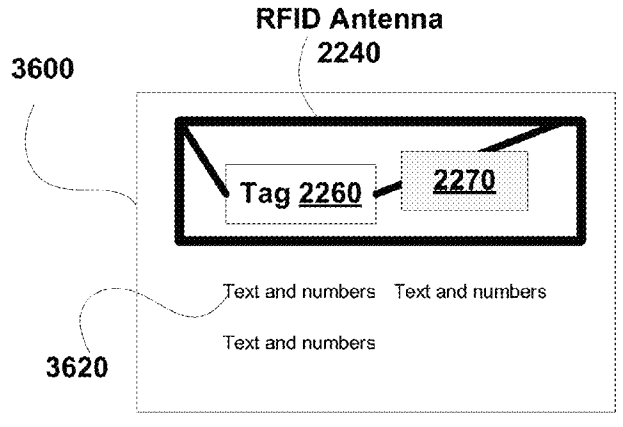

FIG. 37B

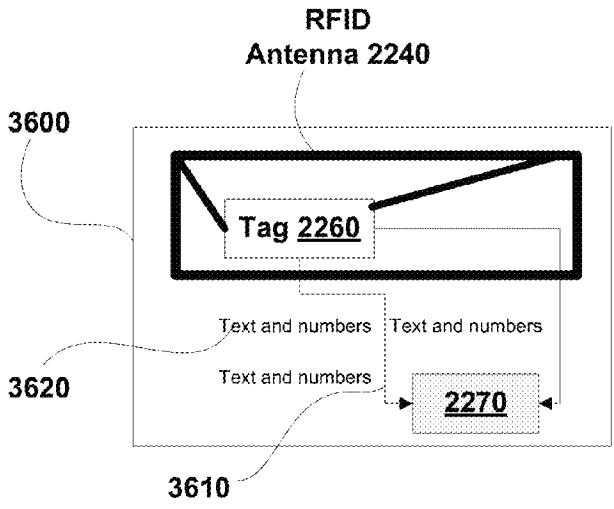

FIG. 37C

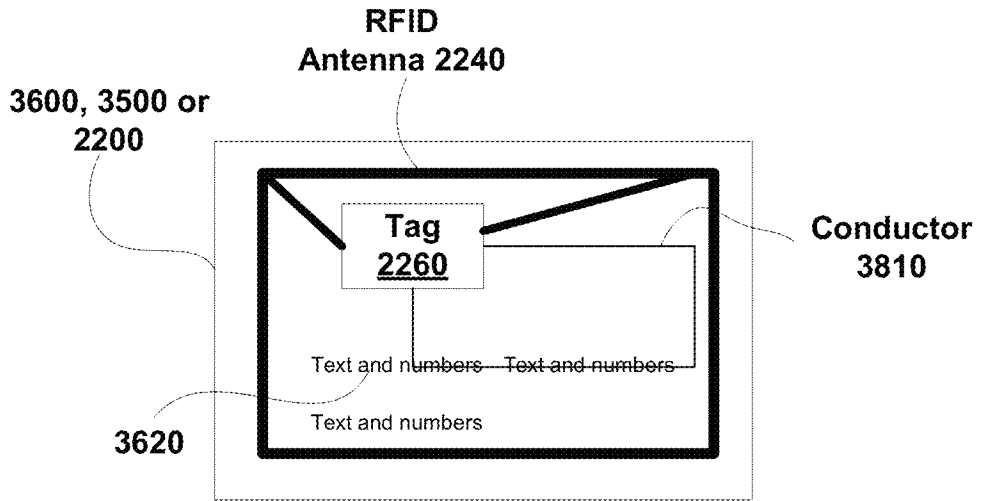

FIG. 38

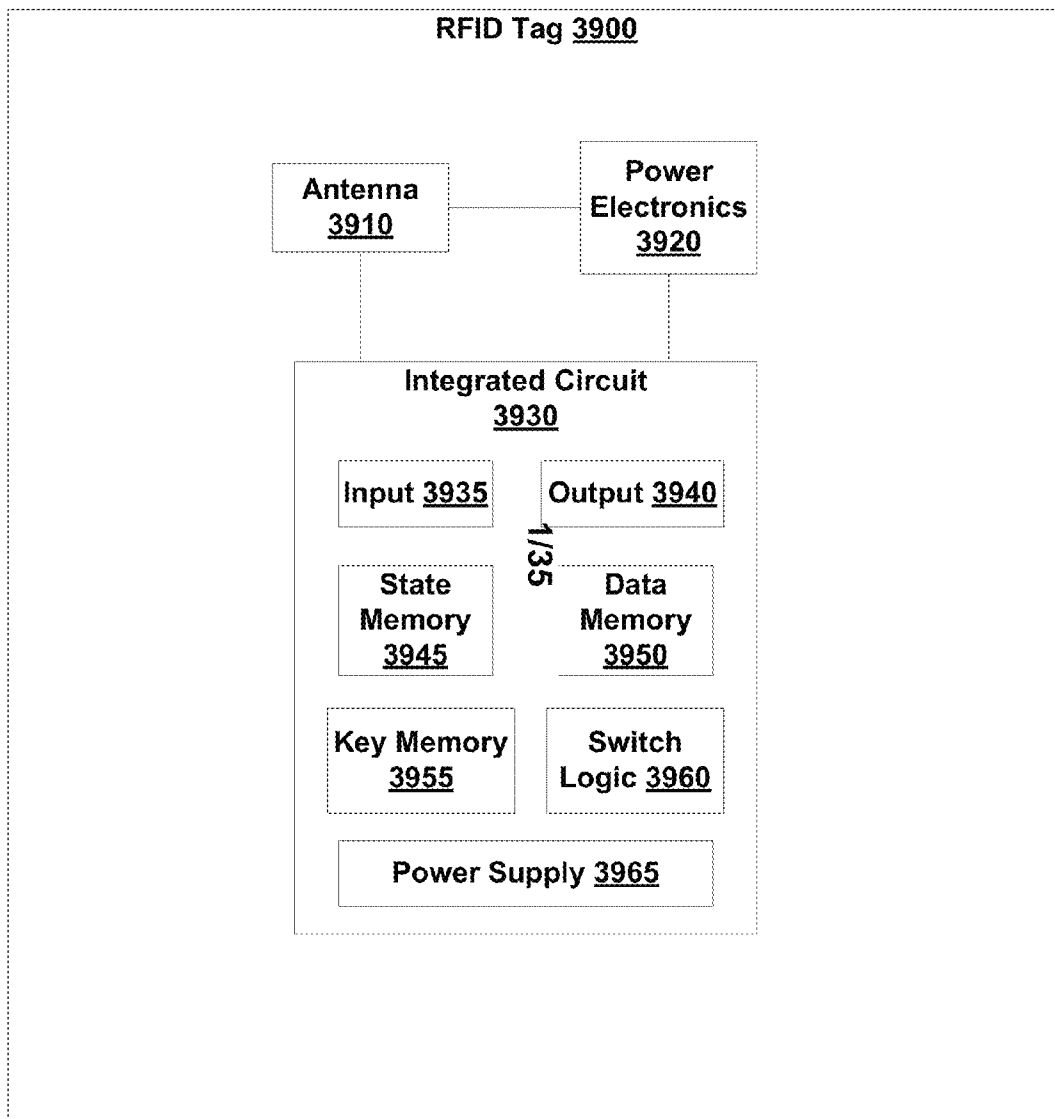

FIG. 39

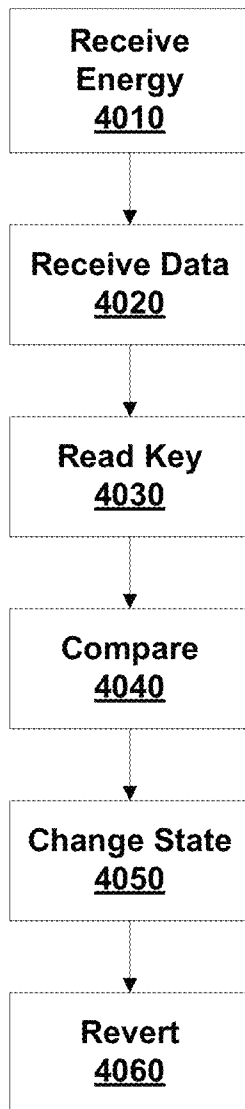

FIG. 40

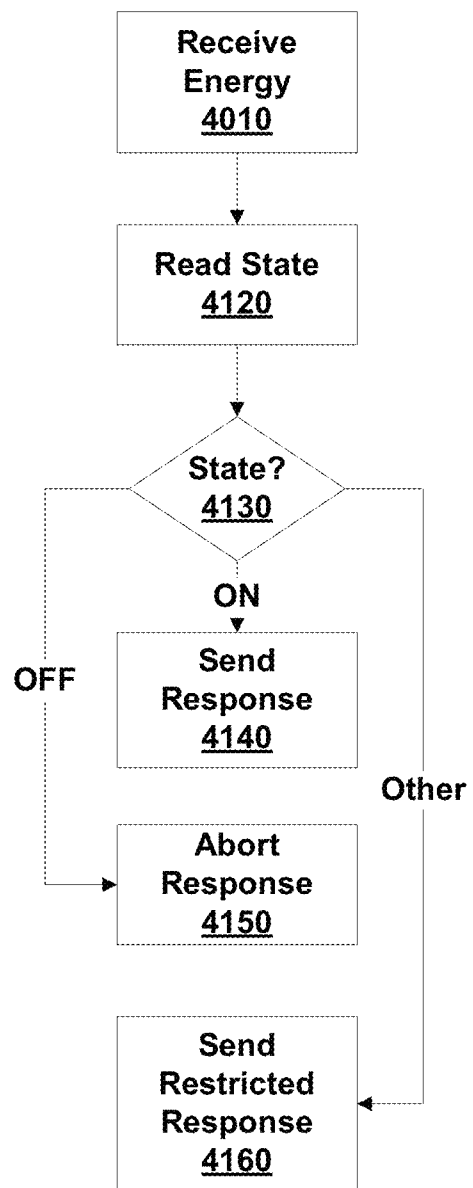

FIG. 41

**EPASSPORT INCLUDING SHIELDING
METHOD**

CROSS-REFERENCE TO RELATED
APPLICATIONS

This application is:

a continuation in part of U.S. non-provisional patent application Ser. No. 13/481,104 filed May 25, 2012; which is in turn is a continuation of Ser. No. 12/777,474 filed May 11, 2010, which in turn is a continuation of Ser. No. 11/350,309 filed Feb. 7, 2006, now U.S. Pat. No. 7,719,425, and claims benefit of provisional patent applications: 60/650,478 filed Feb. 7, 2005, 60/678,428 filed May 6, 2005, 60/685,331 filed May 27, 2005, 60/700,884 filed Jul. 19, 2005, 60/712,308 filed Aug. 30, 2005, 60/715,641 filed Sep. 10, 2005, 60/752,933 filed Dec. 21, 2005, and 60/758,751 filed Jan. 13, 2006;

a continuation in part of U.S. non-provisional patent application Ser. No. 13/084,433 filed Apr. 11, 2011 which in turn is a continuation in part of Ser. No. 11/458,620 filed Jul. 19, 2006, now U.S. Pat. No. 7,924,156 which is a continuation in part of:

Ser. No. 11/382,052 filed May 7, 2006,
Ser. No. 11/382,053 filed May 7, 2006,
Ser. No. 11/382,054 filed May 8, 2006,
Ser. No. 11/382,264 filed May 8, 2006,
Ser. No. 11/382,265 filed May 8, 2006, and
Ser. No. 11/420,721 filed May 26, 2006,
and claims benefit of provisional patent applications:

60/700,884 filed Jul. 19, 2005,
60/712,308 filed Aug. 30, 2005,
60/715,641 filed Sep. 10, 2005,
60/752,933 filed Dec. 21, 2005,
60/758,751 filed Jan. 13, 2006,
60/782,068 filed Mar. 13, 2006,
60/744,154 filed Apr. 3, 2006, and
60/746,636 filed May 6, 2006, and is

a continuation in part of Ser. No. 11/382,050 filed May 7, 2006, which claims benefit of provisional patent applications:

60/678,428 May 6, 2005, and
60/685,331 May 27, 2005; and

a continuation in part of U.S. non-provisional patent application Ser. No. 14/468,110 filed Aug. 25, 2014, which is a continuation of Ser. No. 12/577,209 Oct. 12, 2009, now U.S. Pat. No. 8,816,826, which claims benefit of provisional patent applications:

60/700,884 filed Jul. 19, 2005,
60/712,308 filed Aug. 30, 2005,
60/715,641 filed Sep. 10, 2005,
60/752,933 filed Dec. 21, 2005,
60/758,751 filed Jan. 13, 2006,
60/782,068 filed Mar. 13, 2006,
60/744,154 filed Apr. 3, 2006, and
60/746,636 filed May 6, 2006, and
is a continuation in part of

CIP Ser. No. 11/382,052 filed May 7, 2006,
CIP Ser. No. 11/382,053 filed May 7, 2006,
CIP Ser. No. 11/382,054 filed May 8, 2006,
CIP Ser. No. 11/382,264 filed May 8, 2006,
CIP Ser. No. 11/382,265 filed May 8, 2006,
CIP Ser. No. 11/420,721 filed May 26, 2006, and

CIP Ser. No. 11/382,050 filed May 7, 2006 which claims benefit of provisional patent applications:
60/678,428 filed May 6, 2005, and
60/685,331 filed May 27, 2005.

5 The disclosures of the above provisional and non-provisional patent applications are hereby incorporated herein by reference. The disclosure of U.S. non-provisional patent application Ser. No. 11/350,309 filed Feb. 7, 2006 is also hereby incorporated herein by reference.

BACKGROUND OF THE INVENTION

Field of the Invention

10 The invention is in the fields of electronic passports, and more specifically in the field of electronic passports including shielding and/or switchable RFID tags.

Description of Related Art

15 Radio Frequency identity (RFID) tags are typically small, flexible, and low profile devices that can be affixed to items for electronic tracking and information storage purposes. An RFID tag can be read by an RFID reader when the RFID tag is brought within a certain vicinity of the reader that is broadcasting a radio frequency signal. In some cases, once within that vicinity, the RFID tag receives sufficient power from the radio frequency signal to permit it to transmit a return radio frequency signal using the received power. These RFID tags are referred to as passive RFID tags. In other cases the RFID tag has an independent power source for generating a return radio frequency signal. These RFID tags are referred to as active RFID tags. With either passive or active RFID tags, the return radio frequency signal may include an encoded copy of information stored within the RFID tag. As used herein, RFID tags include radio frequency contactless chips.

SUMMARY

20 The invention includes the use of shielding in relation to RFID tags. For example, some embodiments of the invention include shielded containers for storing devices including RFID tags. These devices can include identification devices such as passports, credit cards, or driver's licenses.

25 Some embodiments of the invention include shielded containers and RFID tags, the RFID tags configured for use in determining a state of the container. For example, detection of an RFID tag can be used to determine if the container is open or closed. These embodiments are optionally used in event logging or security.

30 Some embodiments of the invention include shielding attached to identification devices. This shielding may, for example, be included in a clamshell configuration, as a shielding insert, or as part of a page or cover.

35 Various embodiments of the invention include a container comprising an RFID tag configured for determining if the container is open or closed, and radio frequency shielding configured to shield a signal from the RFID tag responsive to whether the container is open or closed.

40 Various embodiments of the invention include a vehicle comprising a receptacle attached to the vehicle and configured to receive an identification device including an RFID tag, and a radio frequency shielding attached to the receptacle and configured to shield the RFID tag when the identification device is placed within the receptacle.

45 Various embodiments of the invention include a purse comprising a receptacle configured to receive an identification device including an RFID tag, and a radio frequency

shielding attached to the purse and configured to shield the RFID tag when the identification device is placed in the receptacle.

Various embodiments of the invention include a wallet comprising a receptacle configured to receive an identification device including an RFID tag, and a radio frequency shielding attached to the wallet and configured to shield the RFID tag when the identification device is placed in the receptacle.

Various embodiments of the invention include a shielded RFID device comprising an identity device including an RFID tag, and a cover physically attached to the device, the cover including a radio frequency shielding material configured to shield the RFID tag in a first position and to not shield the RFID tag in a second position.

Various embodiments of the invention include an identification device comprising a base including a surface configured to display identifying information, an RFID tag configured to transmit identifying information, and a cover including a radio frequency shielding material configured to shield the RFID tag when closed and to allow the RFID tag to communicate with a reader when open.

Various embodiments of the invention include a passport device comprising an RFID tag configured to transmit identifying information, a surface configured to visually display the identifying information, and an attached cover including a radio frequency shielding material configured to shield the RFID tag when the cover is closed, and configured to enable reading of the RFID tag when the cover is open.

Various embodiments of the invention include a passport device comprising a first cover part including identifying information on an inside surface, a second cover part separated from the first cover part by a fold, an RFID tag within the first cover or the second cover part, and a page between the first cover part and the second cover part, the page including shielding configured for shielding the RFID tag in a first position and not shielding the RFID tag in a second position.

Various embodiments of the invention include a driver's license device comprising an RFID tag configured to transmit identifying information, a surface configured to visually display the identifying information, and a cover including a radio frequency shielding material configured to shield the RFID tag in a first position, and configured to enable reading of the RFID tag in a second position.

Various embodiments of the invention include a credit card device comprising an RFID tag configured to transmit account information, an attached cover including radio frequency shielding and configured to move relative to the RFID tag, to shield the RFID tag in a first position, and not to shield the RFID tag in a second position.

Various embodiments of the invention include a shielding device comprising a shielding material configured to be temporarily attached to an identity device and to shield an RFID tag within the identity device, and an attachment mechanism configured for attaching the shielding material to the identity device.

Various embodiments of the invention include a passport reading system comprising an RFID reader, and a base disposed to form a slot between the base and the RFID reader, a width of the slot configured for passage of a passport in an open position such that shielding material within the passport does not interfere with communications between the RFID reader and an RFID tag included in the passport.

Various embodiments of the invention include a passport reading system comprising a first RFID reader, a second

RFID reader, a third RFID reader, the first, second and third RFID readers surrounding a passport reading volume and being disposed such that at least one of the first, second and third RFID readers will be at a proper angle relative to an antenna of an RFID tag within a passport in the passport reading volume to read the RFID tag, and also disposed such that transmission between the RFID tag and the at least one of the first, second and third RFID readers is not prevented by shielding within the passport when the passport is open in the passport reading zone regardless of the angle of the shielding relative to the first, second and third readers.

Various embodiments of the invention include a system comprising a cover material configured for inclusion in a polarity of identity devices, a strip of shielding deposited on the cover material, a first RFID tag deposited on the cover material, a second RFID tag deposited on the cover material, and a cutting area configured to be cut in order to produce the plurality of identity devices, the cut including cutting of the strip of shielding and separation of the first RFID tag and the second RFID tag.

Various embodiments of the invention include a passport comprising an RFID tag configured to transmit identifying information, a surface configured to visually display the identifying information, and a cover including a first part and a second part separated by a fold, the first part including the RFID tag and the second part including a radio frequency shielding configured to shield the RFID tag when the cover is closed, and configured to allow reading of the RFID tag when the cover is open, the radio frequency shielding including metallic fibers disposed within the second part.

Various embodiments of the invention include a passport comprising a first cover part including identifying information including a photograph on an inside surface, a second cover part separated from the first cover part by a fold, an RFID tag within the first cover or the second cover part, and a page between the first cover part and the second cover part, the page including shielding configured for shielding the RFID tag in a first position and not shielding the RFID tag in a second position.

Various embodiments of the invention include a passport comprising a first cover part including an RFID tag disposed at least 5 mm from a fold, a second cover part separated from the first cover part by the fold and including shielding configured for shielding the RFID tag in a first position of the second cover part and not shielding the RFID tag in a second position of the cover part.

Various embodiments of the invention include a system comprising a cover material configured for inclusion in a polarity of identity devices, a strip of shielding deposited on the cover material, a first RFID tag deposited on the cover material, a second RFID tag deposited on the cover material, and a cutting area configured to be cut in order to produce the plurality of identity devices, the cut including cutting of the strip of shielding and separation of a location for depositing of the first RFID tag and a location for depositing of the second RFID tag.

Various embodiments of the invention include a method comprising depositing a radio frequency shielding material on a first part of a cover material, depositing at least a first radio frequency identity tag and a second radio frequency identity tag on a second part of the cover material, cutting the cover material through the radio frequency shielding, and creating a fold in the flexible material, the fold separating the first part of the cover material from the second part of the cover material.

Various embodiments of the invention include a remotely powered RFID (radio frequency identity) tag having an

electronically controlled switch. This switch is optionally a remotely (wirelessly) controlled switch. In some embodiments, when the switch is in an off state, the RFID tag will not transmit and when the switch is in an on state the RFID tag will transmit in response to an RF (radio frequency) signal. In some embodiments, the switch includes multiple on states in which different information or signals are transmitted responsive to the state of the switch. The RFID tag includes a memory configured to store the states of the RFID tag and an integrated circuit configured to determine whether to transmit responsive to the stored state of the RFID tag and a received RF signal.

Various embodiments of the invention include switchable RFID devices. These switchable RFID devices can include identity documents such as passports or driver's licenses, financial cards such as credit or debit cards, remote controls, security devices, access devices, communication devices, or the like. In some embodiments, more than one switchable RFID tag is included in a single RFID device. In various embodiments, one or more switches are used to change operation of an RFID tag from a responsive state to a non-responsive state, to change operation of an RFID tag from one responsive state to another responsive state, to enter data into an RFID device, to control an external device, or the like. In various embodiments, the switches are electronic, wireless, and/or mechanical.

Various embodiments of the invention includes an RFID tag comprising an antenna configured to receive data in a first RF signal, to receive energy from the first RF signal, and to transmit data in a second RF signal, the transmission of the second RF signal being powered by the energy received from the first RF signal; and an integrated circuit including an input configured to receive data from the antenna and to receive power resulting from the energy received from the antenna, an output configured to provide an RF signal to the antenna for transmission, a state memory configured to store an ON/OFF state of the RFID tag, a key memory configured for storing a key for changing the ON/OFF state stored in the state memory, and a switch logic configured to receive data from the input, to read the key from the key memory, to compare the received data with the read key, and to change the ON/OFF state stored in the state memory responsive to this comparison, the switch logic is further configured to determine whether or not to provide a second RF signal to the antenna for transmission, the determination being responsive to the ON/OFF state stored in the state memory.

Various embodiments of the invention include a method of changing an ON/OFF state of an RFID Tag, the method comprising receiving energy sufficient to power the RFID Tag through an RF antenna included in the RFID tag, receiving first data through the RF antenna, reading a key from a key memory, using an integrated circuit to compare the first data received through the RF antenna with the key read from the key memory, the integrated circuit powered by the received energy, and writing data to state memory responsive to the comparison, the data written to the state memory being configured to change the RFID tag from an OFF state in which the RFID tag will not transmit an RF signal to an ON state in which the RFID tag will transmit an RF signal.

Various embodiments of the invention includes a method of operating an RFID tag, the method comprising receiving energy sufficient to power the RFID tag through an RF antenna included in the RFID tag, reading a state from state memory, sending an RF response through the RF antenna unless the read state is an OFF state.

Various embodiments of the invention includes a method of operating an RFID tag, the method comprising receiving energy sufficient to power the RFID tag through an RF antenna included in the RFID tag, reading a state from state memory, sending an RF response through the RF antenna if the read state is an ON state, and disabling the RF response through the RF antenna if the read state is an OFF state.

Various embodiments of the invention includes a method of operating an RFID tag, the method comprising receiving energy sufficient to power the RFID tag through an RF antenna included in the RFID tag, reading a state from state memory, sending an RF response through the RF antenna only if the read state is an ON state.

Various embodiments of the invention includes a multi-layer identity document comprising a first outer layer, an electrical conductor configured to conduct a current, a spacer layer including an opening configured to contain a switch activator, the switch activator configured to make and break an electrical connection to the electrical connector, and an inner layer disposed such that the spacer layer and switch activator are between the first outer layer and the second outer layer, the inner layer being configured to be pressed to activate the switch activator.

Various embodiments of the invention includes a switchable RFID tag comprising an antenna configured to receive an RF transmission, an integrated circuit configured to generate a response transmission, and a switch configured to turn on and of the ability of the integrated circuit to generate the response transmission, the switch being disposed such that it is surrounded by the antenna.

Various embodiments of the invention includes a system comprising a plurality of switches configured for a user to enter data, logic configured to transmit a first wireless signal responsive to the entered data, and a circuit configured to receive energy from a received second wireless signal and to power the logic and the transmission of the system using the received energy.

Various embodiments of the invention includes a system comprising logic configured to transmit a first wireless signal in response to a received second wireless signal, a wireless I/O configured to receive the second wireless signal and to transmit the first wireless signal, a memory configured to store an account number, the account number being included in the first wireless signal, a physical contact I/O configured for writing the account number to the memory, logic configured to allow writing of the account number to the memory if the account number is received via the physical contact I/O but if the account number is received via the wireless I/O, and a circuit configured to receive energy from the received second wireless signal and to power the logic and the transmission of the first wireless signal using the received energy.

Various embodiments of the invention includes a system comprising logic configured to transmit a first wireless signal in response to a received second wireless signal, a wireless I/O configured to receive the second wireless signal and to transmit the first wireless signal, the second wireless signal including an identification data associated with a reader, a memory configured to store a log of received identification data received from a plurality of readers, a physical contact I/O configured for uploading the log of received identification data from the memory, logic configured to allow uploading of the log of received identification data from the memory via the physical contact I/O but via the wireless I/O, and a circuit configured to receive energy

from the received second wireless signal and to power the logic and the transmission of the first wireless signal using the received energy.

Various embodiments of the invention includes a method comprising mounting a plurality of RFID antenna and RFID tags on a support, mounting a the support on a first side of a spacer, the spacer including opening **140** and optionally including one or more cavity to receive the RFID tags, mounting a cover layer on a second side of the spacer, and cutting the support and spacer to generate a plurality of RFID enabled financial Cards.

Various embodiments of the invention include a method comprising mounting an RFID antenna and RFID tag on a support, mounting a spacer on the support, the spacer being compliant (soft) so that the RFID tag can enter a plane of the spacer to form a cavity, allowing the spacer to harden, and mounting a cover layer on the spacer.

Various embodiments of the invention include a method of assembling an identity device, the method comprising depositing an integrated circuit, antenna and switch contacts on a support layer, and laminating the support layer, spacer and flexible membrane together, the spacer having a cavity in which the integrated circuit fits.

Various embodiments of the invention include a method of assembling an identity device, the method comprising depositing an integrated circuit, antenna and switch contacts on a support layer **150**, depositing spacer **120** on the support layer, spacer **120** covering the integrated circuit, and depositing a flexible membrane on the support layer, the flexible membrane or the support layer optionally including an image of a user. The Spacer is optionally configured to create a hermetic seal around the integrated circuit and/or the RFID antenna.

Various embodiments of the invention include a method comprising programming data to non-volatile memory of an RFID tag in a programmable mode, and changing a state of a switch coupled to the RFID tag so as to change the RFID tag from the programmable mode to a non-programmable mode.

Various embodiments of the invention include an RFID tag comprising an antenna configured to transmit data, a power circuit configured to provide power, an integrated circuit configured to receive power from the power circuit, to provide the data to the antenna, the integrated circuit including a non-volatile memory configured to store the data and a logic circuit configured to determine a state of a switch, the switch being configured to control whether the volatile memory can or cannot be programmed.

Various embodiments of the invention include an integrated circuit comprising a first logic input configured for determining a state of a switch, a power input configured to receive power from a radio frequency antenna, the received power being sufficient for powering the integrated and transmitting a data output signal via the radio frequency antenna, and a data output configured for generating the data output responsive to the state of the switch as determined by the first logic input.

Various embodiments of the invention include an Identity Device comprising an RFID antenna configured to receive power from and communicate with an RFID reader, a circuit configured to receive power from the RFID Antenna, a tag configured to be powered by power received through the RFID antenna and to generate a signal for transmission between the RFID antenna and the RFID reader, and a switch configured to repeatedly turn on and turn off detectability or readability of the tag.

Various embodiments of the invention include a locking mechanism comprising a RFID tag activation circuit configured to turn on a switchable RFID tag by operating a switch within the switchable RFID tag, an RFID reader configured to read the switchable RFID tag, and a lock configured to open responsive to the RFID reader.

Various embodiments of the invention include a method of operating an RFID tag, the method comprising activating a switch in order to turn on the detectability or readability of the RFID tag, the RFID tag powered by power received through an RFID antenna, and activating the switch in order to turn off the detectability or readability of the RFID tag. In some embodiments, the switch is configured to keep the readability of the RFID tag off until the switch is activated again. The switch optionally being included in an identity device.

Various embodiments of the invention include a method of operating a switchable RFID tag, the method comprising operating a switch to turn the RFID tag on, responsive to a first action of a user, receiving a signal at an RFID antenna, collecting power from the signal, using the collected power to power an integrated circuit, collecting data from the signal, processing the collected data using the integrated circuit, transmitting a signal generated by the integrated circuit in response to the collected data, using the RFID antenna, and operating the switch to turn the RFID tag off, responsive to a second action of a user.

Various embodiments of the invention include a switchable RFID tag comprising an RFID antenna configured to receive power from and communicate with an RFID reader, a tag configured to be powered by power received through the RFID antenna and to generate a signal for transmission between the RFID antenna and the RFID reader, and a switch configured to repeatedly turn on and turn off detectability or readability of the tag.

Various embodiments of the invention include a method of controlling an electronic device, the method comprising receiving a wireless RF signal from an RF transmitter, converting the received RF signal into electronic power, generating a wireless return signal using the electronic power, the wireless return signal configured to control the electronic device, placing a switch in a first position to turn on the generation of the wireless return signal, placing the switch in a second position to turn off the generation of the wireless return signal, and returning the switch to the first position to turn on the generation of the wireless return signal.

Various embodiments of the invention include a method of controlling an electronic device, the method comprising receiving a wireless RF signal from an RF transmitter; converting the received RF signal into electronic power; repeatedly changing a switch from a first position to a second position; and generating a wireless return signal using the electronic power, the wireless return signal configured to control the electronic device and being responsive to whether the switch is in the first position and the second position.

Various embodiments of the invention include a system comprising an antenna configured to receive a wireless RF signal from an RF transmitter, a power circuit configured to convert the RF signal into electronic power, a circuit configured to receive the electronic power and to send a wireless response signal in response to the RF signal, and a first switch configured to repeatedly turn on and off a first operation of the circuit under control of a user.

Various embodiments of the invention include a method of receiving control instructions, the method comprising,

generating a wireless RF signal, transmitting the wireless RF signal to a RF powered remote control device configured to send a wireless return signal responsive to the states of one or more switches, the return signal being generated and transmitted using power converted from the wireless RF signal, receiving the return signal, and determining the states of the one or more switches using the received return signal.

Various embodiments of the invention include a system comprising a RF transmitter configured to send a wireless RF signal, a controlled device, a RF powered remote control configured to be powered by the wireless RF signal and to send a wireless response signal to the controlled device responsive to a first switch, the first switch configured to be repeatedly turned on and off by a user.

Various embodiments of the invention include a method of operating an RFID tag, the method comprising receiving energy sufficient to power the RFID tag through an RF antenna included in the RFID tag, reading a state from state memory, and sending an RF response through the RF antenna unless the read state is an OFF state.

Various embodiments of the invention include a method of operating an RFID tag, the method comprising receiving energy sufficient to power the RFID tag through an RF antenna included in the RFID tag, reading a state from state memory, sending an RF response through the RF antenna if the read state is an ON state, and disabling the RF response through the RF antenna if the read state is an OFF state.

Various embodiments of the invention include a method of operating an RFID tag, the method comprising receiving energy sufficient to power the RFID tag through an RF antenna included in the RFID tag, reading a state from state memory, sending an RF response through the RF antenna only if the read state is an ON state.

BRIEF DESCRIPTION OF DRAWINGS

FIG. 1 illustrates a container including a receptacle configured to store an ID incorporating an RFID tag, according to various embodiments of the invention.

FIG. 2 illustrates a container including an RFID tag or alternatively an RFID tag reader.

FIG. 3 illustrates various monitoring systems that employ illustrative embodiments of the container of FIG. 2.

FIG. 4 illustrates further details of an embodiment of the container of FIG. 2 that includes a monitored vial.

FIG. 5 illustrates another embodiment of a monitored vial that includes more than one compartment.

FIG. 6 illustrates an embodiment of the container of FIG. 2 wherein the container is a room.

FIG. 7 illustrates an access system based on an RFID tag, according to various embodiments of the invention.

FIG. 8 illustrates a clamshell ID including a base including an RFID tag and a cover connected to the base, according to various embodiments of the invention.

FIG. 9 illustrates a clamshell ID similar to that shown in FIG. 8 except that the base and cover are pivotally connected at a point rather than along an edge, according to various embodiments of the invention.

FIGS. 10A and 10B illustrate an ID similar to that shown in FIGS. 8 and 9 except that the cover is configured to fit into the base, according to various embodiments of the invention.

FIG. 11 illustrates further detail of some embodiments of a clamshell ID having a first cover and second cover separated by a fold.

FIG. 12 illustrates further embodiments of a clamshell ID including a first cover and second cover separated by a fold.

FIG. 13 illustrates a clamshell ID wherein shielding is added to a page, according to various embodiments of the invention.

FIG. 14 illustrates an identification device, according to various embodiments of the invention.

FIG. 15 illustrates a method of allowing communication to an RFID tag, according to various embodiments of the invention.

FIG. 16 illustrates a method of modifying an RFID enabled identification device, according to various embodiments of the invention.

FIG. 17 illustrates a method of making an identity device including, according to various embodiments of the invention.

FIG. 18 is a block diagram illustrating a stage in the manufacture of an identification device, according to various embodiments of the invention.

FIG. 19 illustrates the method of manufacturing an identification device, according to various embodiments of the invention.

FIG. 20 illustrates an RFID reader system, according to various embodiments of the invention.

FIG. 21 illustrates an alternative RFID reader system, according to various embodiments of the invention.

FIG. 22 is a block diagram of a switchable RFID device, according to various embodiments of the invention;

FIGS. 23 and 24 illustrate some of many possible locations for a switch within a switchable RFID device, according to various embodiments of the invention;

FIG. 25A illustrates an OFF Position of a switch, according to various embodiments of the invention;

FIG. 25B illustrates an ON position of a switch, according to various embodiments of the invention;

FIGS. 26A and 26B illustrates a membrane switch, according to various embodiments of the invention;

FIG. 26C illustrates an embodiment of a membrane switch including a spring, according to various embodiments of the invention;

FIG. 26D illustrates a cross-sectional view of a membrane switch disposed within a switchable RFID Tag, according to various embodiments of the invention;

FIG. 27 illustrates a top view of a membrane switch, according to various embodiments of the invention;

FIG. 28 illustrates a switchable RFID tag in an identity document, according to various embodiments of the invention;

FIG. 29 illustrates the manufacture of instances of an identity document, according to various embodiments of the invention;

FIG. 30 illustrates an exploded view of an embodiment of a switchable RFID device including a driver's license, according to various embodiments of the invention;

FIG. 31 illustrates an embodiment of a switchable RFID device including a plurality of switches, according to various embodiments of the invention;

FIG. 32 illustrates various embodiments of an tag configured for use in embodiments of a switchable RFID device including a plurality of switches, according to various embodiments of the invention;

FIG. 33 illustrates an instance of a tag, according to various embodiments of the invention;

FIG. 34 illustrates a method according to various embodiments of the invention, according to various embodiments of the invention;

FIG. 35 illustrates a switchable RFID device configured to operate as a remote control, according to various embodiments of the invention;

11

FIG. 36 illustrates a multiswitch credit card, according to various embodiments of the invention;

FIGS. 37A-37C illustrate an antenna within a credit card, according to various embodiments of the invention;

FIG. 38 illustrates an RFID device including a conductor configured to set a state of an RFID tag, according to various embodiments of the invention.

FIG. 39 is a block diagram illustrating an RFID tag, according to various embodiments of the invention;

FIG. 40 is a flowchart illustrating a method of changing a state of the RFID tag illustrated in FIG. 22, according to various embodiments of the invention; and

FIG. 41 is a flowchart illustrating a method of operating the RFID tag illustrated in FIG. 22, according to various embodiments of the invention.

DETAILED DESCRIPTION

Various embodiments of the present invention includes holders (e.g., containers) including radio frequency shielding materials to protect items, such as IDs (identification devices), incorporating RFID tags from being read. In some embodiments, a person can allow information within an RFID tag to be read by removing the item from the holder, while in other embodiments the holder is merely opened or removed to allow the RFID tag to be read. Replacing the item within the holder, or closing the holder, secures the item's RFID tag from unwanted readings from, or detection by, unknown or unauthorized RFID readers. It will be appreciated that items other than IDs, such as library books, consumer electronics, medications, and so forth, can also include, or be packaged with, RFID tags that a person may wish to shield from unauthorized RFID readers. Holders specifically tailored for such items, as well as general purpose holders such as wallets, purses and briefcases, can also include radio frequency shielding (also referred to herein as shielding) according to the present invention.

The holder can be in the general form of a container as an illustrative example, having two similar rectangular sides joined around three edges, being configured to be repeatedly opened and close, and optionally including a closure or flap along the fourth side. Such holders are well suited to the typical shape of most personal IDs such as passports, driver's licenses, green cards, credit and debit cards, medical information cards, insurance cards, medical alerts, student identification cards, security badges, immigration documents, or the like. Typically, the holder is configured to be repeatedly opened and closed to receive the ID.

The holder can also be a case such as a carrying-case for a cell phone or digital camera. The holder can also be a purse, suitcase, backpack, briefcase, satchel, glove compartment, a jewelry container, and the like. In some embodiments, the RF shielding is physically attached to the holder. The holder can alternatively include a checkbook holder, a wallet, a ticket holder, or a windshield visor pocket. Some embodiments of the invention are directed at articles of clothing in which one or more pockets include an attached radio frequency shielding material. Additional embodiments are directed to key holders.

The desirability of RFID shielding for the objects listed above will be readily appreciated. Being able to read an RFID tag on a green card (an immigration document) without the owner of the green card giving consent or being aware that the green card is being read, for example, can enable less scrupulous individuals to engage in improper behaviors. Incorporating RFID shielding into a wallet, purse, or other type of holder would prevent an RFID tag on

12

an item within the holder from being read unless the item is deliberately exposed to the RFID reader, for instance, by removing the item from the holder. In view of the problem of identity theft, such shielding is desirable for credit cards with RFID tags, social security cards with RFID tags, driver's licenses with RFID tags, and so forth.

In some instances the RFID tag is essentially a label that has been attached to an object for inventory or similar purposes. Library books can carry RFID tags, for example. Accordingly, providing RFID shielding for various carrying devices, such as purses, suitcases, book bags, briefcases, and satchels can prevent RFID tags in library books and other objects from being read without permission. In other instances the RFID tag is more integral with an object. Consumer electronics, electronic media, and so forth, can be manufactured to include RFID tags inside of housings, on printed circuit boards, and on electronic components, for example. Often, such devices have specially designed cases such as cell phone cases and camera cases. These cases can also comprise RFID shielding to prevent the RFID tags in the associated devices from being read without authorization.

In some embodiments, the holder is clear (e.g., transparent) so that the ID, such as a driver's license, can be readily seen without having to be removed from the holder. Many wallets include either a plastic sleeve or a leather pocket with a plastic window for this purpose. In some embodiments, of the invention in which at least part of the holder is transparent, the shielding in the transparent region needs to also be transparent. Certain electrically conductive polymers can serve as the RFID shielding material in these embodiments. Other transparent and non-transparent materials for RFID shielding are discussed further herein.

In some embodiments, the holder is designed to allow the ID to be easily and repeatedly removed and returned. For instance, some credit and debit cards have a smaller format (mini-cards) and can be stored in a matching case that can serve as a fob for keys. In some of these embodiments, the holder and the ID card are pivotally attached to one another so that the ID card can flip out from the holder, and in still further embodiments a spring mechanism aids in extending and retracting the ID card. Other cases of the present invention can comprise a clamshell configuration. Such ID card holders of the present invention include an RFID shielding material.

The present invention also provides for articles of clothing designed to include pockets that can shield RFID tags on objects within the pockets. In these embodiments the articles of clothing can be made from a cloth that includes a radio frequency shielding material, or the pocket can be lined with the radio frequency shielding material.

The present invention also provides for key holders comprising RFID shielding. The keys that are held by such key holders can be either mechanical or electronic, where mechanical is used herein to refer to keys meant to fit into mechanical locks such as car keys, house keys, and the like. Electronic keys refer to keys that carry an encoded password on a magnetic strip, a bar code, an RFID tag, or the like. Either type of key can include an RFID tag as either a further component of the locking mechanism or for completely unrelated reasons. An RFID tag on a key is part of the locking mechanism, for example, when the lock reads the RFID tag for some purpose, such as to read the key numbers from RFID tags on different keys in order to track which keys are being used in the lock.

Electronic keys are often placed on ID badges and other forms of identification. An RFID tag with such electronic

keys may carry confidential information but be unrelated to the lock mechanism. In some embodiments, the key holder is retractable, and in some of these embodiments the key holder is spring-loaded to automatically retract the key into the key holder.

In the embodiments described herein, the holder, whether an container, case, article of clothing, or key holder, has some form of opening through which the ID or other object having an RFID tag can be transferred. In some embodiments, the holder also includes a closure for closing the opening. In some of these embodiments, the closure can comprise a flap that closes over the opening. In other embodiments the closure is a zipper, Velcro, or related closure device. The closure can provide an electrical contact between opposing sides of the opening, in some instances.

In some embodiments, the RFID shielding material is incorporated into an ID. For example, a passport can include an RFID shielding material in the passport's cover so that an RFID tag within the passport can only be read when the passport is opened. Similarly, a driver's license can include a clamshell cover and base including an RFID shielding material, or a pivoting cover including an RFID shielding material.

The RFID shielding material can be provided in numerous different ways. The radio frequency shielding material can include a conductive material such as a metal or an electrically conductive plastic. The RFID shielding can be attached using adhesive. The radio frequency shielding material can include a mesh with a mesh size small enough to provide shielding against the radio frequency range used by RFID readers. The radio frequency shielding material can be laminated, either by laminating the RFID shielding material to another layer, such as a protective material layer, and/or by laminating together multiple layers of RFID shielding materials. In many embodiments the RFID shielding material is either flexible, transparent, or both. Examples of suitable RFID shielding materials include metal-coated elastomers such as aluminized Mylar and copper-coated plastic sheets and films. In some embodiments, the RFID shielding material is a semi-transparent mesh.

In some embodiments, the RFID shielding material is effective to form a Faraday cage around the ID, object, or key. Closing the closure can be effective to complete the Faraday cage, in some instances. In other embodiments the RFID shielding is used in selective locations in the holder. For example, where a nation's passport includes an RFID tag in a lower right-hand corner of the cover, passport holders designed for that nation's passports need only include RFID shielding above and/or below the location of the RFID tag when the passport is in the passport holder.

The RFID shielding shields an RFID tag from a reader in two ways. First, the RFID shielding greatly reduces the power being broadcast from the reader that reaches the RFID tag within the holder. This cuts the power available to the RFID tag to transmit information back. Secondly, even if the RFID tag receives enough power to transmit, the signal sent from the RFID tag is also attenuated. Accordingly, it will be appreciated that the effectiveness of the RFID shielding can be varied considerably based on choices of radio frequency shielding materials and their thicknesses, mesh sizes, and so forth. In some embodiments, the radio frequency shielding material provides a reduction of input power to the RFID tag by between about 5db-30db, 10db-25db, 15db-20db, or more than 15, 25, 35 or 45 db.

In some embodiments, the container is configured to be repeatedly opened and closed to receive an item including an

RFID tag. In some embodiments, the container includes a closure configured to enhance the shielding.

In some embodiments, the container configured to just fit a standard California driver's license. These embodiments may be characterized by inner dimensions of less than 3.5 inches, 3.75 inches, 4 inches or 4.5 inches height, and less than 2.25 inches, 2.5 inches or 2.75 inches in width. In some embodiments, the container is configured to just fit a U.S. passport or a passport issued by another country. These embodiments may be characterized by inner dimensions of less than 5 inches, 5.25 inches, 5.5 inches or 6 inches in height, and less than 3.5 inches, 3.75 inches, 4 inches or 4.5 inches in width.

FIG. 1 illustrates a Container **100** including a Receptacle **110** configured to store an ID **130** (identification device) incorporating an RFID Tag **140**. The Container **100** and Receptacle **110** may include a wallet, purse, passport holder, key chain, ticket holder, pocket, sleeve, slot, opening, niche, compartment, lid & base, glove compartment, jewelry, suitcase, backpack, bag, carrier, carton, box, sack, carton, casing, shell, carapace, covering, sheath, or the like. Container **100** further includes attached Shielding **120** configured to attenuate the transmission of radio frequency signals to or from the RFID Tag **140**. Receptacle **110** is configured to be repeatedly opened and repeatedly closed for insertion and removal of ID **130**.

FIG. 2 illustrates an embodiment of a Container **200** including RFID Tag **140** or alternatively an RFID tag Reader **210**. Container **200** is optionally an embodiment of the Container of FIG. 1, and visa-versa. Container **200** further includes Shielding **120** configured to attenuate the transmission of radio frequency signals to or from the RFID Tag **140** or Reader **210**. The shielding effect of the Shielding **120** is optionally dependent on a state of the Container **200**. For example, in some embodiments, the Shielding **120** may be more efficient at attenuating RF transmission when Container **200** is closed than when it is open. As such, in some embodiments, the state of the Container **200** may be determined by a magnitude of a detected radio frequency signal between RFID Tag **140** and Reader **210** either of which may be within Container **200**.

FIG. 3 illustrates various monitoring systems that employ illustrative embodiments of Container **200**. These illustrative embodiments include a wall hanging (e.g., a Picture **320**), a Refrigerator **325**, a Jewelry Box **330**, a Chest of Drawers **335**, a Monitored Vial **340**, a Filing Cabinet **345**, and a Safe **350**. In these embodiments, the monitoring systems further include RFID tag Reader **210** and optional Alarm and/or Log **310**. Each of these examples of Container **200** include one or more RFID Tag **140** and Shielding **120** (whether shown or not) configured to modify the transmission of RFID signals from Reader **210** to RFID Tags **140** responsive to a state of the Container **200**.

For example, the Picture **320** illustrated includes Shielding **120** (not shown) that surrounds the RFID Tag **140** while Picture **320** is mounted on Wall **330**. Shielding **120** is configured such that the attenuation effect of the shielding will be reduced if Picture **320** is removed from Wall **330**. For example, Shielding **120** may be disposed to form a Faraday cage around or interfere with the RFID Tag **140** (e.g. be on the back of the picture, optional standoffs, and/or wall) and if Picture **320** is removed from Wall **330** a resulting gap, or reduction in interference, will allow increased RFID signal transmission between the associated RFID Tag **140** and Reader **210**. Picture **320** may alternatively be a statue or some other object designed to sit on a surface with an RFID tag between the object and the surface.

In a similar manner each of the Refrigerator **325**, Jewelry Box **330**, Chest **335**, Monitored Vial **340**, Filing Cabinet **345** and Safe **350** includes Shielding **120** configured such that a magnitude of an RFID tag signal received by Reader **210** is dependent on whether the particular container is open or not.

Reader **210** is configured to detect RFID signals from one or more of the RFID Tags **140** and to generate a responsive output signal. In some embodiments, this responsive output signal is a quantitative or qualitative indication of the state of one or more of the containers. The reader is optionally configured to distinguish the signals received from each of the one or more RFID tags and, thus, identify which of the containers is open.

Alarm/Log unit **310** is optionally an alarm system or a logging system configured to activate an alarm or log an event responsive to the output signal of Reader **210**. For example, in some embodiments, the Alarm/Log unit **310** is configured to activate an alarm when Picture **320** is removed from the wall or Safe **350** is opened. In some embodiments, the Alarm Log unit **310** is configured to log when Filing Cabinet **345**, Chest **335** or Drawers or Refrigerator **325** is opened.

In alternative embodiments, Reader **210** may be placed within the container and RFID Tag **140** outside.

FIG. **4** illustrates further details of an embodiment of the Container of FIG. **2** that includes Monitored Vial **340**. Monitored Vial **340** includes shielding in a Lid **410** and/or Base **420**. When the Lid **410** and Base **420** are attached the shielding attenuates any signal from the enclosed RFID Tag **140**. When Lid **410** is opened the attenuation is reduced. The RFID tag is optionally disposed on the underside of Lid **410**. The illustrated embodiments are optionally used to monitor the use of medication or other material stored within Monitored Vial **340**. The monitored vial is optionally an alternative form of Container **200** and optionally configured to store alternative types of goods. In some embodiments, Reader **210** of FIG. **3** is configured to log when Monitored Vial **340** is opened and closed. For example, if a user has a medication that should be taken at a specific time Reader **210** may be used to detect if Monitored Vial **340** is opened at these times and activate a reminder using Alarm/Log **310** if Monitored Vial **340** is not opened at a time medication should be taken.

FIG. **5** illustrates another embodiment of Monitored Vial **340** that includes more than one Compartment **510**. Each Compartment **510** includes a separate RFID Tag **140** that may be separately identifiable using Reader **210**. This embodiment may be used, for example, to monitor an activity that should occur at a variety of different times (e.g., times of day or days of the week.).

FIG. **6** illustrates an embodiment of the Container of FIG. **2** wherein Container **200** includes a Room **610**. In these embodiments, radio frequency signals between RFID Tag **140** and Reader **210** may be used to determine if an opening to the room is open. Room **610** includes Shielded Wall(s) **620** that block radio frequency signals between Tag **140** and Reader **210** when an Opening **630** is closed. When Opening **630** is open Tag **140** can be detected by Reader **210** and this stage can be logged by Alarm/Log **310**. While the illustration shows Reader **210** within Room **610** and RFID Tag **140** outside, these positions are optionally exchanged. Room **610** is optionally a shipping container. RFID Tag **140** is optionally mounted on Opening **630** such that Tag **140** is brought within reading range of Reader **210** when Opening **630** is opened. Opening **630** can be, for example, a window or door.

FIG. **7** illustrates an access system based on an RFID Tag **140**. RFID Tag **140** is optionally implanted within a Animal

or Person **720** or attached to an animal collar. A Reader/Lock Control **710** is configured to detect a signal from RFID Tag **140** and to control a Lock **740** in response. Lock **740** controls the function of a Barrier **730**, such as a door or gate. Reader/Lock Control **710** is optionally programmable to operate responsive to particular instances of RFID Tag **140**.

The Reader/Lock Control **710** illustrated in FIG. **7** is optionally used in the following manner. RFID Tag **140** is placed within or attached to the Animal or Person **720**. Reader/Lock Control **710** is placed in a programming mode. A serial number of the RFID Tag **140** is programmed into the Reader/Lock Control **710** either by digital data entry or communication, or by bringing the RFID Tag **140** within the reading range of the Reader/Lock Control **710**, such that the serial number can be read from the RFID Tag **140**. The Reader/Lock Control **710** is placed in a normal operation mode wherein it monitor's for the presence of the RFID Tag **140**. The RFID Tag **140** is detected by the Reader/Lock Control **710**. The serial number is read from the detected RFID Tag **140** by Reader/Lock Control **710**. Reader/Lock Control **710** compares the read serial number with the serial number programmed into the Reader/Lock Control **710** while in the programming mode. If the read and programmed serial numbers agree Lock **740** is activated in response. Activation of Lock **730** controls (e.g., locks or unlocks) access through Barrier **730**. After the detected RFID tag is no longer detected by the Reader/Lock Control **710**, Reader/Lock Control **710** optionally reactivates Lock **740** to return it to a previous state.

FIG. **8** illustrates a Clamshell ID **810** (e.g. greencard (immigration card), passport, driver's license, transaction card, key card, national identity card, or the like). Transaction cards include credit cards, debit cards, check cards, payment cards, fare (e.g., transit) cards, or the like. Clamshell ID **810** includes an optional picture, a Base **830** including an RFID Tag **140**, and a Cover **820** connected to Base **830** in a clamshell configuration, e.g., connected along an edge or Fold **840**. Cover **820** and/or Base **830** include RFID shielding configured to attenuate radio frequency signals to or from RFID Tag **140** when Cover **820** is closed (e.g., shut), and to not attenuate, or attenuate to a lesser extent, radio frequency signals to or from RFID Tag **140** when Cover **820** is open. The shielding is optionally laminated into Base **830** and/or Cover **820**. In some embodiments, Clamshell ID **810** includes shielding in both Base **830** and Cover **820**. Base **820** can be the cover of a passport or other document. In some embodiments, Base **830** includes a plastic card.

In various embodiments, Clamshell ID **810** includes a passport, driver's license, credit card, etc. that includes RF shielding in one part (e.g., a page or cover) and an RFID tag in another part (e.g., a different page or cover). Not shown in FIG. **8** are pages that may be included between the covers (e.g., Base **830** and Cover **820**). The RF shielding and RFID Tag **140** are configured such that, when Clamshell ID **810** is closed the shielding interferes with the RF pickup of the RFID tag to an extent sufficient for reading of RFID Tag **140** to be attenuated.

In some embodiments, Clamshell ID **810** can be closed in two ways. First, such that a picture and/or other identification information is displayed on the exposed surface of Base **830**. Or, second, such that the picture and/or other identification information are covered by Cover **820**. These two methods of closure are achieved by rotating Cover **820** and Base **830** relative to each other in different directions around Fold **840**. In the first instance, the picture and/or other identification information can be used for identification

while RFID Tag **140** is still shielded. Thus, Clamshell ID **810** can be used for identification (non-RFID) without unshielding RFID Tag **140**.

When the Clamshell ID **810** is open, the shielding is less close to RFID Tag **140** and, thus, the interference of the shielding is reduced and RFID Tag **140** can be read. The shielding does not necessarily form a Faraday cage around RFID Tag **140** when Clamshell ID **810** is closed. In some embodiments, shielding is not included in the part of Clamshell ID **810** that includes the RFID Tag **140**. Clamshell ID **810** is optionally formed by laminating RFID Tag **140** and RF shielding between layers of Cover **820** or to a page disposed between Cover **820** and Base **830**. Further visible information such as a name and/or photograph can be placed on any surface of the Clamshell ID. Thus, in some embodiments, this visible information is visible when the Clamshell ID is open or closed. In other embodiments, this visible information is visible only when the Clamshell ID is open.

FIG. **9** illustrates an ID **910** similar to that shown in FIG. **8** except that Base **830** and Cover **820** are pivotally connected at a Pivot Point **920** rather than in a clamshell configuration. Cover **820** is configured to rotate over Base **830** as shown. When Cover **820** covers the Base **830** the RFID Tag **140** is shielded. When Cover **820** is rotated away from Base **830** RFID Tag **140** is unshielded. In some embodiments, Cover **820** may have two sections between which Base **830** fits. Either Cover **820** and/or Base **830** can include the RF shielding.

FIGS. **10A** and **10B** illustrate an ID similar to that shown in FIGS. **8** and **9** except that Cover **820** is configured to fit into Base **839**, or visa versa. In the example shown, Cover **820** slides into and out of a slot in Base **830** and thus shields and exposes, respectively, RFID Tag **140**. This embodiment may include an item to be worn such as a medical alert bracelet, an identity tag, a ring, clothing, glasses, or the like. For example, in the case of a medical alert bracelet, the bracelet includes an RFID tag (having medical information) that is only readable when a cover element of the bracelet is opened to expose the RFID tag to an RFID tag reader. When the cover is opened medical personal can read data from the RFID tag. When the cover is closed the medical information is shielded from being read by unauthorized persons and is thus kept confidential.

One embodiment of the invention includes the credit card (**16**) and case having sides (**12**) and (**14**) as illustrated in U.S. patent application Pub. 2004/0117514. In this embodiment, credit card (**16**) further (additionally) includes an RFID Tag **140** and sides (**12**) and/or (**14**) n further include RF shielding, or visa versa. The credit card may be replaced by an alternative type of ID device, e.g., a driver's license, debit card, or others discussed herein.

On embodiment of the invention includes the credit card (**3**) and holder (**1**) as illustrated in U.S. patent application Pub. 2005/0011776. In this embodiment, credit card (**3**) further includes an RFID Tag **140** and the holder (**1**) further includes RF shielding. The credit card may be replaced by an alternative type of ID device, e.g., a driver's license, debit card, or the like.

One embodiment of the invention includes the carrying case taught in U.S. patent application Pub. 2004/0256469, wherein the carrying case further includes RF shielding.

One embodiment of the invention includes the credit card and pivoting case described in U.S. patent application Pub. 2004/0237360, wherein an RFID tag is included in one part (e.g., the credit card) and shielding in another part (e.g., the case). Thus, when the credit card is pivoted into the case the RFID tag is shielded. One embodiment of the invention

includes a credit card and case illustrated in FIG. 10 of U.S. patent application Pub. 2004/0237360. In this embodiment, the credit card includes an RFID Tag **140** and the case includes shielding. The credit card may be replaced by an alternative type of ID device, e.g., a driver's license, debit card, or the like.

One embodiment of the invention includes the security wallet illustrated in U.S. Pat. No. 4,744,497, wherein the security wallet further includes RFID shielding.

Various embodiments of the invention include the foldable transaction cards illustrated in US. Patent Applications Pubs. 2004/0169087 and 2004/0089724, wherein shielding is further included in one side of the fold while RFID Tag **140** is further included in the other side. RFID Tag **140** is shielded when the transaction card is folded closed and unshielded when it is open.

Various embodiments of the invention include the several different folding cards illustrated in U.S. Pat. No. 5,700,037 and Application Pub. 2005/0205665. Wherein these cards further include RFID Tag **140** in one part and shielding in another part, such that in one fold position RFID Tag **140** is shielded by the shielding, and in another fold position RFID Tag **140** is un-shielded.

One embodiment of the invention includes the credit card case illustrated in U.S. patent application Pub. 2002/0117243. Where in the credit card case further includes shielding configured to shield an rfid enabled credit card or other identification device.

FIG. **11** illustrates further detail of some embodiments of Clamshell ID **810**, having a First Cover **1110** and a Second Cover **1120** separated by Fold **840**. First Cover **1110** and a Second Cover **1120** may be, for example, Base **830** and Cover **820**. Fold **840** can be a spine, hinge, crease, or the like. In alternative embodiments, First Cover **1110** and/or Second Cover **1120** can be embodied as a page or pages between covers of an identity document. Shielding **1130** is disposed as part of the second cover (e.g., or on or in an ID document cover or page). Shielding **1130** is optionally disposed away from fold **840** such that, when Clamshell ID **810** is open, the shielding as well separated from RFID Tag **140**. In various embodiments, the separation between shielding **1130** and Fold **840** is greater than 5 mm, 10 mm, 15 mm, 20 mm, 25 mm or 30 mm. Likewise, RFID Tag **140** is optionally disposed away from Fold **830**. In various embodiments, the separation between RFID Tag **140** (including antenna) and Fold **840** is greater than 5 mm, 10 mm, 15 mm, 20 mm, 25 mm or 30 mm. Alternatively, RFID Tag **140** and/or Shielding **1130** may be disposed to abut Fold **840**.

FIG. **12** illustrates embodiments of Clamshell ID **810** including a First Cover **1210** and a Second Cover **1220** separated by Fold **830**. These embodiments further include a Page **1230** disposed between First Cover **1210** and Second Cover **1220**. Page **1230** includes RFID Tag **140** or Shielding **1130**. For example, these embodiments of Clamshell ID **810** can include a passport including a photograph and identity information within an inside surface (facing toward Page **1230**) of First Cover **1210**, RFID Tag **140** within First Cover **1210** or Second Cover **1220**, and Shielding **1130** within Page **1230**. RFID Tag **140** can be shielded and un-shielded by moving Page **1230** close to or away from RFID Tag **140**. In embodiments, wherein RFID Tag **140** is included in Second Cover **1220**, RFID Tag **140** is shielded when Page **1230** is held close to Second Cover **1220**. In this position is may be possible to view the photograph and identity information within the inside surface of First Cover **1210** without

un-shielding RFID Tag 140. When Page 1230 is moved away from Second Cover 1220 then RFID Tag 140 is unshielded.

By including the RF Shielding 1130 with one of the one or more Page 1230, Clamshell ID 810 can be opened without necessarily removing Shielding 1130 from the vicinity of RFID Tag 140. For example, if RFID Tag 140 is disposed within the back cover, and Clamshell ID 810 is opened such that the inside of the First Cover 1210 is visible, Page 1230 including Shielding 1130 could remain adjacent to Second Cover 1220 and thus limit communication with the RFID Tag 140. To allow communication with RFID Tag 130 Page 1230 including Shielding 1130 is turned such that it moves away from Second Cover 1220. The Shielding 1130 may be attached to Page 1230 or be included within Page 1230. For example, Shielding 1130 may be laminated within Page 1230, be sewn on Page 1230, be glued on Page 1230, be within the material of Page 1230, or otherwise be connected to Page 1230. In various embodiments, Shielding 1130 includes a wire mesh, metallic fibers, metallic particles, metallic thread, or the like. Shielding is optionally attached to a binding of Clamshell ID 810 as Page 1230. Page 1230 is optionally bound to Clamshell ID by stable, pin, wire, thread, adhesive, laminate, or the like.

FIG. 13 illustrates embodiments of Clamshell ID 810 wherein Shielding 1130 is added to Page 1230 following assembly of Clamshell ID. In these embodiments, Shielding 1130 is included in a Shielding Insert 1310. Shielding Insert 1310 optionally includes Adhesive 1320 or some other mechanism for attaching Shielding Insert 1310 to Page 1230. The attachment of Shielding Insert 1310 to Page 1230 can be permanent or temporary (e.g., Shielding Insert 1310 may be removable). In various embodiments, Shielding Insert 1310 includes a metal plate, wire mesh, metallic fibers, metallic particles, metallic thread, or other forms of shielding.

The size of Shielding Insert 1310 is optionally the same as or slightly smaller than a European Union Passport, a Japanese Passport, a Chinese Passport, a United States Passport, or the like. Alternatively, in various embodiments, Shielding Insert 1310 is configured in size such that it can be attached to Clamshell ID 810 at least greater than 5 mm, 10 mm, 15 mm, 20 mm, 25 mm or 30 mm from Fold 830. For example, Shielding Insert 1310 may be configured to attach to Page 1230 such that Shielding Insert 1310 extends from near an outer edge (opposite Fold 830) of Page 1230 to within 10 mm of Fold 830.

FIG. 14 illustrates embodiments of an Identification Device 1410, such as Clamshell ID 810. In these embodiments, Shielding Insert 1310 includes one or more clips 1420, clamp, pin, slot, rivet, or other mechanism configured for, optionally temporary, attaching Shielding Insert 1310 to Identification Device 1410. In some embodiments Clip 1420 is replaced by a slot configured to receive that part of Identification Device 1410 including an RFID tag. Shielding Insert 1320 is optionally pivotally connected to Identification Device 1210. In the embodiments illustrated by FIG. 14, Fold 830, Second Cover 1220 and Page 1230 are optional. For example, Identification Device 1410 can be a single piece driver's license, credit card, etc. (without separate front and back covers) including RFID Tag 140. Shielding Insert 1310 is configured to be attached to First Cover 1210, Page 1230, and/or Second Cover 1220. In these embodiments Page 1230 need not include shielding. In some embodiments, Shielding Insert 1310 may be attached to that part of Identification Device 1410 that includes RFID Tag 140. In these embodiments, Shielding Insert 1310 is inserted

to shield RFID Tag 140 and removed in order to un-shield RFID Tag 140. In some embodiments, Shielding Insert 1310 includes a flat metal plate configured to fit within a passport, e.g., a passport issued by the United States, a European Country, or an Asian Country. In these embodiments, the size of shielding insert may be similar to or slightly smaller than the dimensions of the passport. In some embodiments, Shielding Insert 1310 can include an attachment device, such as Clip 1420, on more than one side (face). As such, Shielding Insert 1310 may be configured to shield and RFID enabled driver's license on one side and an RFID enabled credit card on the other side. Shielding Insert 1310 is optionally approximately the size of a driver's license or credit card. In some embodiments, Shielding Insert 1310 has height and width dimensions similar to or smaller than a page between the front cover and the back cover. Shielding Insert 1310 is optionally thin and optionally flexible.

As illustrated in FIG. 15, some embodiments of the invention include a method of allowing communication to an RFID tag. The method includes a Step 1510 of opening a front cover of an identification device, such as Clamshell ID 810 or Identification Device 1410, in order to make information included on the inside of the front cover visible, an RF shielding page being kept in proximity of the back cover such that an RF tag within the back cover is unreadable. The RF shielding page can be for example an instance of Page 1230 or a page with Shielding Insert 1310 attached. The method further includes a Step 1520 of visually presenting the information on the inside of the front cover. The information can include a name, citizenship, photograph, identification number, or the like. A step 1530 includes turning the shielding page away from the back cover such that the RFID tag becomes un-shielded and can communicate with a reader. The shielding page is a page, between the front cover and the back cover, that includes or is attached to RF shielding configured to limit communication with the RFID tag. In alternative embodiments of this method, the rolls of the front cover and back cover are reversed.

As illustrated in FIG. 16, some embodiments of the invention include a method of modifying an RFID enabled identification device, e.g., Identification Device 1410. This method includes, a Step 1610 of opening the identification device by turning a back cover away from a front cover; a Step 1620 of selecting a page disposed (optionally bound) between the front cover and the back cover; an optional Step 1630 of exposing an adhesive surface on an RF shielding insert, the RF shielding configured to limit RF communication between an RFID tag included in the identification device and a reader; and a Step 1640 of attaching the RF shielding insert to the selected page using the exposed adhesive. In alternative embodiments, the adhesive is optionally replaced by a clip, clamp, pin, slot, or other mechanism configured for temporary attachment to the identification device. The identification device is optionally a passport, driver's license, immigration document, national identity document, or other identification device discussed herein. The RF shielding insert is optionally sized (as discussed elsewhere herein) such that it is disposed at a distance from a fold in the identification device.

As illustrated by FIG. 17, one embodiment of the invention includes a method of making an identity device including: a Step 1710 of adding an RFID tag to a first cover layer; a Step 1720 of adding a second cover layer such that the RFID tag is disposed between the first cover layer and the second cover layer; and a Step 1730 of attaching an RF shield to the combined first cover layer and second cover layer. The RF shield is optionally attached as a page con-

figured to be disposed between to parts of the combined first cover layer and second cover layer when the combination is folded. The RF shield is optionally temporarily attached to the combined first cover layer and second cover layer.

FIG. 18 is a block diagram illustrating the manufacture of an identification device, such as a passport. At one stage in the manufacturing process Shielding 1130 is dispensed in the form of a strip. The strip is laid down over what will be several separate identification devices when the manufacturing is completed. A plurality of RFID Tags 140 are deposited. The assembled material, including shielding is cut along a Cutting Line 1820 (cutting area) to separate the locations where the RFID Tags 140 are deposited or to be deposited. As a result a plurality of identity documents are produced. The cut along Cutting Line 1820 occurs after Shielding 1130 is laid down. Pages are optionally added to the assembled material prior to cutting.

FIG. 19 illustrates the method of illustrating an identification device as shown in FIG. 18. In an Add Shielding Step 1910, shielding is added to an area of a cover that will become a first identification device and a second identification device. In an Add RFIDs Step 1920, a first RFID tag is added to that part of the cover that will become the first identification device and a second RFID tag is added to that part of the cover that will become the second identification device. In a Cut Step 1930, the cover is cut to separate that part that will become the first identification device and that part that will be come the second identification device. Cut Step 1930 includes cutting the shielding added in Add Shielding Step 1910.

FIG. 20 illustrates an RFID reader system configured to read Clamshell ID 810 e.g., an RFID enabled passport including shielding. Spacing between an RFID Reader 2010 and a Base 2020 is configured to form a Passport Slot 2030. RFID Reader 2010 is configured to read Clamshell ID 810. The height of Passport Slot 2030 is configured such that Clamshell ID 810 is sufficiently open when passed through Passport Slot 2030 between the RFID Reader 2010 and Base 2020. E.g., Passport Slot 2030 is configured such that, in order to pass through Passport Slot 2030 Clamshell ID 810 cannot be partially open such that shielding within Clamshell ID 810 could block the communication between RFID Reader 2010 and the RFID tag included in Clamshell ID 810. The width of the passport slot is optionally configured to assure that the shielding is not disposed between the RFID reader and the RFID tag.

FIG. 21 illustrates an RFID reader system including more than one RFID readers (RFID Reader 2010A, RFID Reader 1010B, and optionally RFID Reader 1010C). The more than one RFID readers are disposed such that any shielding within an ID is never within the line of sites between all of the one or more RFID readers and an RFID tag in a reading volume. And in addition, the more than one RFID readers are disposed such that the angle between an antenna of the RFID tag is at least one of the RFID readers is favorable for communicating between the RFID tag and RFID reader. Achieving both or these criteria may require three or more RFID readers. In alternative embodiments, this system may include fewer or more RFID readers than illustrated. The illustrated readers optionally surround a walk through reading volume.

FIG. 22 is a block diagram of a Switchable RFID Device 2200. In some embodiments, Switchable RFID Device 2200 is an identity device such as a passport, identity card, driver's license, immigration document (e.g., green card or visa), student identity card, library card, financial card (e.g., credit card, debit card or prepaid card), social security card,

Military ID card, key, keycard or the like. Switchable RFID Device 2200 optionally includes Visible Indications 2220 such as a barcode, picture, image, name, address, text, and/or the like. Switchable RFID Device 2200 further includes one or more Switchable RFID Tag 2230. Switchable RFID Tag 2230 includes one or more RFID Antenna 2240, a Circuit 2250, one or more Tag 2260 and one or more Switch 2270. Switch 2270 is optionally disposed within Circuit 2250 or Tag 2260. RFID Antenna 2240 is configured for sending a radio frequency (RF) signal from Switchable RFID Device 2200 in response to a received signal. The received signal is optionally used to power Switchable RFID Tag 2230. In some embodiments, the received signal is an RF signal received by RFID Antenna 2240. In alternative embodiments, the received signal is received through an inductive coupling or a non-RF antenna within Circuit 2250. RFID Antenna 2240 is optionally a dipole antenna.

In some embodiments, Switchable RFID Tag 2230 is configured for a user to be able to repeatedly turn on and off the function (e.g., delectability or readability) of Tag 2260 using Switch 2270. Circuit 2250 typically further includes a diode, capacitor, transistor, and/or the like configured to receive power through RFID Antenna 2240 or an inductive coupling and to convey signals between RFID Antenna 2240 and Tag 2260. In some embodiments, Tag 2260 includes an integrated circuit.

Switchable RFID Tag 2230 is differentiated from circuits found in RFID tags of the prior art by at least the inclusion of Switch 2270. Switch 2270 is optical, thermal, magnetic, mechanical, wireless, and/or electronic. Switch 2270 is configured to be activated by a magnetic field, an electric field, a wireless signal, light, heat, mechanical force, and/or an electronic circuit external to Switchable RFID Device 2200. Switch 2270 is optionally a sliding switch, a flip switch, a rotating switch, membrane switch, pushbutton switch, or other mechanical switch known in the art of mechanical switches. In typical embodiments, Switch 2270 is configured for both turning on and turning off function of Tag 2260.

In various embodiments, Switch 2270 is normally open or normally closed, and the function of Tag 2260 can be normally on or normally off. For example, In some embodiments, Switch 2270 is a mechanical contact switch activated by applying pressure to an outside surface of Switchable RFID Device 2200. In some embodiments, when this pressure is applied the functionality of Tag 2260 will be turned on, and when this pressure is not applied the functionality of Tag 2260 will be off. In some embodiments, Switch 2270 is a mechanical contact switch activated using a magnetic field. In some embodiments, Switch 2270 is an electrical switch turned on or off by a circuit external to Switchable RFID Device 2200. For example, Switch 2270 may include two electrical contacts exposed at the exterior of Switchable RFID Tag 2230. When a conductance path, current and/or voltage is applied between these electrical contacts Switch 2270 is turned on, or in alternative embodiments, turned off.

In various embodiments, Switch 2270 functions by creating a short circuit. For example, Switch 2270 can be configured to turn off the function of Tag 2260 by short circuiting RFID Antenna 2240, a diode within Circuit 2250, a capacitor within Circuit 2250, a transistor within Circuit 2250, and/or a connection within Tag 2260.

In various embodiments, Switch 2270 functions by creating an open circuit. For example, Switch 2270 can be configured to create an open circuit between (or within) RFID Antenna 2240, Circuit 2250, and/or Tag 2260.

In some embodiments, Switchable RFID Device **2200** is configured to operate as a key and Switch **2270** is activated to turn on the functions of Tag **2260** by mechanical insertion of the key into a locking device. In these embodiments, the functions of Tag **2260** are typically off when the key is not inserted in the locking device. The locking device is configured to activate Switch **2270** using an electronic circuit, a mechanical force, or a magnetic field.

In alternative embodiments, an instance of Switch **2270** is included in Tag **2260** and/or Circuit **2250**. Thus, Switchable RFID Tag **2230** may include a plurality of Switch **2270**, one Switch **2270** in Circuit **2250** and one Switch **2270** in Tag **2260**. As is described further herein, these instances of Switch **2270** may be configured to perform different functions.

FIG. **23** illustrates some of many possible locations for Switch **2270** within Switchable RFID Device **2200** where Switch **2270** creates an open circuit. FIG. **24** illustrates some of many possible locations for Switch **2270** within Switchable RFID Device **2200** wherein Switch **2270** creates a short circuit. The embodiments illustrated by FIGS. **23** and **24** include a Transistor **2310**, a Diode **2320**, and a Capacitor **2330**. Possible positions for Switch **2270** are indicated by an "X."

In some embodiments, Switch **2270** is configured to partially limit the functionality of Tag **2260**. Thus, Tag **2260** may be configured to respond with data indicating a first state when Switch **2270** is on and to respond with data indicating a second state when Switch **2270** is off. For example, Switch **2270** can be connected to logic circuits of Tag **2260** in such a way that Tag **2260** will transmit a limited amount of data when Switch **2270** is off and a less limited amount of data when Switch **2270** is on. For example, Tag **2260** may be configured to respond with data indicating the name of a person when Switch **2270** is off and to respond with the data including the name, an address, an account number and a telephone number when Switch **2270** is on. When Switch **2270** is connected to a circuit within Tag **2260**, Switch **2270** (or a plurality thereof) is optionally configured to separately control detection of and readability of Tag **2260**. Detection occurs when Tag **2260** sends any response signal, while readability is a function of the data that may be included in the contents of the response signal.

FIGS. **25A** and **25B** illustrate one embodiment of Switchable RFID Device **2200** in which Switch **2270** is a sliding switch disposed along an Edge **2520** of Switchable RFID Device **2200**. FIG. **25A** illustrates an OFF Position wherein an Electrical Connector **2510** between Circuit **2250** and Tag **2260** is in an open circuit state. In this state, Tag **2260** is not normally detectable or readable. FIG. **25B** illustrates an ON position wherein Switch **2270** completes an electrical connection between Circuit **2250** and Tag **2260**. In this position, Tag **2260** is detectable and readable. In this embodiment, Switch **2270** is configured to be moved between the on position and the off position, for example using a finger. In the on position, Switch **2270** optionally extends from Edge **2520** of Switchable RFID Device **2200**. In the off position, Switch **2270** is optionally approximately flush with Edge **2520**. Some embodiments of the invention include a switch configured to be approximately flush with an edge of a financial card (e.g., credit card or debit card) in at least one position. Some embodiments of the invention include a switch configured to be below an edge of a financial card in at least one position. Switch **2270** may be bistable or astable. Other features illustrated in FIGS. **25A** and **25B** are optional.

FIGS. **26A** and **26B** illustrates a Membrane Switch, generally designated **2600**, (and surrounding area) for use in

a switchable RFID device such as Switchable RFID Device **2200**. Membrane Switch **2600** is optionally an embodiment of Switch **2270**. Membrane Switch **2600** is shown in the OFF and ON positions, in FIGS. **26A** and **26B** respectively. The use of a finger to operate Membrane Switch **2600** is optional, other devices may be used to activate the switch. By bringing electrical conductors on a Surface **2630** and a Surface **2625** together, a switchable RFID tag is controlled, activated or deactivated. Typically, Surface **2625** and Surface **2630** are coated with an electrical conductor, such as copper. In some embodiments, a Support Layer **2610** is disposed at a First Surface **2615** of Switchable RFID Device **2200** and a Flexible Membrane **2620** is disposed at a Second Surface **2635** of Switchable RFID Device **2200**. Thus, the Flexible Membrane **2620** includes both Surface **2625** and an outer surface, e.g., Surface **2635** of Switchable RFID Device **2200**. In some embodiments, Surface **2635** extends beyond Membrane Switch **2600** to Surrounding Areas **2650**. As such Flexible Membrane **2620** is essentially flush with a surface of Switchable RFID Device **2200**. Flexible membrane **2620** and Support Layer **2610** are separated by a Spacer **2640**. In some embodiments, Spacer **2640** extends beyond the immediate vicinity of Membrane Switch **2600** to Surrounding Areas **2650**. Spacer **2640** optionally extends essentially throughout Switchable RFID Device **2200**. As such, Surface **2635** can be essentially smooth, e.g. does not include raised portions near Membrane Switch **2600**. Support Layer **2610** is typically stiffer than Flexible Membrane **2620**.

In various embodiments, Membrane Switch **2600** is included in an identity device such as a passport, driver's license, immigration card, key card, financial card, ID card, or the like. For example, in some embodiments, Membrane Switch **2600** is included within a passport or other identity device having a clamshell configuration. In these embodiments, Flexible Membrane **2620** is optionally disposed toward an interior of the identity device when the identity device is closed. In this position, Flexible Membrane **2620** is protected from inadvertent contact and typically can only be pressed after the identity device is opened.

In various embodiments, Membrane Switch **2600** is included in a financial card (e.g., a credit card, debit card or the like). In some of these embodiments, Flexible membrane **2620** is essentially flush with Surrounding Areas **2650** of the financial card including Surface **2625**, as illustrated in FIGS. **26A** and **26B**. In this position Membrane Switch **2600** does not substantially stick out from First Surface **2625** of the financial card and is, thus, protected by Surrounding Areas **2650** from inadvertent activation. In some embodiments, Membrane Switch **2600** is recessed below First Surface **2635**.

FIG. **26C** illustrates an embodiment of Membrane Switch **2600** further including a Spring **2655**. Spring **2655** may be considered a switch activator. Spring has an activation height at which the spring center will spring into contact with the Support Layer **2610** this activation height is typically below First Surface **2635**.

FIG. **26D** illustrates a cross-sectional view of Membrane Switch **2600** disposed within Switchable RFID Tag **2230**. Tag **2260** is at least partially disposed within Spacer **540** and/or Support Layer **2610**. Spacer **2640** and/or Support Layer **2610** optionally include a cavity configured to receive Tag **2260**. In some embodiments, Tag **2260** is deposited on Support Layer **2610** before Spacer **2640** is deposited on Support Layer **2640**. In these embodiments, Support Layer **2640** is formed around Tag **2260**. In some embodiments, Spacer **2640** is configured to hermetically seal Tag **2260** and/or Membrane Switch **2600**.

25

In various embodiments, an Opening 2670 within Membrane Switch 2600 is less than or equal to 2.0 mm, 1.5 mm, 1.75 mm, 1.25 mm, 1.0 mm, 0.75 mm, or 0.5 mm thick as measured from Surface 2625 to Surface 2630.

The membrane switch illustrated in FIGS. 26A and 26C is optionally disposed such that Flexible Membrane 2620 is approximately flush with, or recessed in, First Surface 2635 of an identity device such as a driver's license or credit card. As such, Spacer 2640 prevents the membrane switch from being activated when a force is applied to the entire first surface. For example, when the identity device is placed within a wallet and the wallet is compressed.

Spacer 2640 optionally extends essentially throughout an identity device. For example, where Switchable RFID Device 2200 is a credit card, Spacer 2640 may extend to the outer edges of the credit card. Flexible Membrane 2620 optionally includes a picture of a user and/or an indication of the location of Opening 2670 in Spacer 2640. In some embodiments, Flexible Membrane 2620 is transparent and Spacer 2640 includes a picture of a user or a credit card number. In some embodiments, Spacer 2640 includes a cavity configured to fit an integrated circuit, the integrated circuit configured to operate as part of Tag 2260 and optionally mounted on Support Layer 2640. In some embodiments, Support Layer 2640 includes conductive traces configured to connect Tag 2260 to an RFID Antenna 2240. In some embodiments, Spacer 2640 is generally rectangular in shape, (e.g., in the shape of a financial card).

FIG. 27 illustrates a top view of Membrane Switch 2600 of FIG. 26C, according to various embodiments of the invention. In these embodiments, the shape of the Opening 2670 is configured to prevent Spring 2655 from rotating. A wide variety of alternative shapes may be used in alternative embodiments.

FIG. 28 illustrates Switchable RFID Tag 2230 in an embodiment wherein Switchable RFID Device 2200 includes an Identity Document 2800 having a clamshell configuration (e.g., a passport). Switchable RFID Tag 2230 may be included in a Cover 2840, a Cover 2830, or an interior page (not shown) of Identity Document 2800. Identity Document 2800 optionally includes Shielding 2810. Flexible Membrane 2620 is typically disposed such that it is on the interior of Identity Document 2800 when Identity Document 2800 is closed. See U.S. Pat. No. 7,719,425 issued May 18, 2010 for further details of Identity Document 2800, according to some embodiments.

FIG. 29 illustrates the manufacture of instances of Identity Document 2800. At one stage in the manufacturing process, Shielding 2810 is dispensed in the form of a strip. The strip is laid down over what will be several separate instances of Identity Document 2800 (after when the manufacturing is completed). A plurality of Switchable RFID Tag 2230 are deposited, creating a device including several Switchable RFID Tag 2230. The assembled material, including Shielding 2810 is optionally cut to separate the locations where the instances of Switchable RFID tag 2230 are deposited or to be deposited. As a result a plurality of Identity Document 2800 are produced. Pages are optionally added to the assembled material prior to cutting. See U.S. non-provisional patent application Ser. No. 11/350,309 filed Feb. 7, 2006 for further details, according to some embodiments.

In the above and other embodiments, Switchable RFID Tag 2230 is optionally disposed such that the switch mechanism is accessed from the inside of Cover 2830 or Cover 2840, the inside being the sides that face each other when Identity Document 2800 is closed. This orientation is option-

26

ally configured to reduce the probability of inadvertently activating Switch 2270 when Identity Document 2800 is closed. For example, in these embodiments, Flexible membrane 2610 may be to the inside (of the closed Identity Document 2800) and Support Layer 2610 may be to the outside. Support Layer 2610 optionally includes a stiffener in the region near Opening 2670.

FIG. 30 illustrates an exploded view of an embodiment of Switchable RFID Device 2200 including a Driver's License, generally designated 3000. In this view, for clarity, Spacer 2640 is removed and Flexible Membrane 2620 is separated from Tag 2260, RFID Antenna 2240, Circuit 2250 and Support Layer 2610. A location of Membrane Switch 2600 is indicated by Markings 3020 visible at Flexible Membrane 2620. Surface 2635 is of uniform level across the face of Driver's License 3000. As such, Switchable RFID Device 2200 can smoothly be placed in a wallet and Membrane Switch 2600 is protected from inadvertent activation by Spacer 2640. Membrane Switch 2600 is optionally disposed at least partially within RFID Antenna 2240. A similar embodiment of Switchable RFID Device 2200 may include a credit card or similar financial device.

FIG. 31 illustrates an embodiment of Switchable RFID Device 2200 including a plurality of Switches, designated 3110, 3120 and 3130. These embodiments of Switchable RFID Device 2200 may include an identity device, financial device, credit card, debit card, remote control, product label, communication device, or the like. Any of Switches 3110, 3120, and 3130 are optional. Switch 3130 is configured for turning Switchable RFID Device 2200 ON and OFF. For example, as illustrated, Switch 3130 may be disposed in a connection between RFID Antenna 2240 and a Power Circuit 3140. Power Circuit 3140 is an embodiment of Circuit 2250 configured to generate electrical power from a received signal to power Tag 2260.

Switch 3110 and Switch 3120 are configured to control processing logic within Tag 2260. For example, in some embodiments, Switch 3110 and Switch 3120 are configured to provide Boolean (true/false) values to a logic circuit within Tag 2260. Some embodiments include further switches (e.g., 3, 4, 6, 8, 10 or more) configured to control processing logic.

In various embodiments, the processing logic within Tag 2260 can be configured to perform a wide variety of functions responsive to Switch 3110, Switch 3120, and any additional switches present. For example, in some embodiments, the processing logic is configured such that when Switch 3110 is activated a transaction amount is approved and when Switch 3120 is activated the transaction amount is disapproved. Alternatively, Switch 3110 and Switch 3120 may be part of a set of switches used to enter a PIN (personal identification number), an encryption key, an amount, an authorization code, an RFID reader identification number, an identification number associated with Switchable RFID Device 2200, a selection of a mode of Tag 2260, text, numbers, and/or other data.

In some embodiments, data sent by Tag 2260 using RFID Antenna 2240 is responsive to Switch 3110 and/or Switch 3120. For example, in some embodiments, Tag 2260 will send a different identification number depending on whether Switch 3110 or Switch 3120 is activated. In some embodiments, Tag 2260 is configured to allow a transaction up to a certain value if neither Switch 3110 nor Switch 3120 is activated, and progressively higher values if Switch 3110 or Switch 3120 is activated. In some embodiments, Tag 2260 is configured to require that Switch 3110 and Switch 3120 be activated in a specific combination, order and/or with a

specific temporal pattern in order to perform some operation, e.g., a financial transaction.

While the embodiment of Switchable RFID Device 2200 illustrated in FIG. 31 includes one instance of Tag 2260, as discussed elsewhere herein, Switchable RFID Device 2200 optionally includes more than one instance of Tag 2260. When more than one instance of Tag 2260 is present, a separate instance of Switch 3130 may be disposed between RFID Antenna 2240 (or Circuit 2250) and each instance of Tag 2260. In this configuration, the instances of Switch 3130 may be used to select which instance of Tag 2260 to activate. Switch 3110 and/or Switch 3120 may, likewise, be configured to select, activate or control different instances of Tag 2260.

In some embodiments, Switchable RFID Device 2200 includes a Memory 3150. Memory 3150 is optionally programmable. For example, in some embodiments, Memory 3150 is programmable using data entered through instances of Switch 3110 and Switch 3120. In some embodiments, Memory 3150 is changed from a write state to a read only state, using Switch 3110. In various embodiments, Memory 3150 is configured to store data to be broadcast, encryption information, data keys, values to be used in conjunction with data entered using Switch 3110, data for logic processing, identifying data, account data, mode data characterizing a mode of Switchable RFID Tag 2230, or the like. Memory 3150 can be volatile or non-volatile, FLASH, SDRAM, ROM, DDRAM, DRAM, or the like. Some embodiments of the invention include an automated device configured to actuate Switch 2270 in order to place Switchable RFID Tag 2230 in a programmable mode.

FIG. 32 illustrates various embodiments of Tag 2260 configured for use in embodiments of Switchable RFID Device 2200 including a plurality of switches. In the illustrated embodiments, Tag 2260 includes a First Logic Input 3210 and an optional Second Logic Input 3220, configured to be coupled to Switch 3110 and Switch 3120, respectively. First Logic Input 3210 and Second Logic Input 3220 are each configured to be responsive to a different switch. First Logic Input 3210 and Second Logic Input 3220 are configured to control the function of Tag 2260.

For example, in some embodiments, Tag 2260 is configured to output different data via a Data Input/Output 3240 depending on the state of Switch 3110 as determined by the First Logic Input 3210. Tag 2260 is optionally configured to output different data depending on whether a switch coupled to First Logic Input 3210 or a switch coupled to Second Logic Input 3220 is activated.

In some embodiments, the switches illustrated in FIG. 32 are membrane switches. In some embodiments, the switches illustrated in FIG. 32 are irreversible switches.

FIG. 33 illustrates an instance of Tag 2260, according to various embodiments of the invention. These embodiments include a plurality (e.g., 2, 3, 4, 8, 10, 12 or more) of switch inputs, such as First Logic Input 3210, Second Logic Input 3220 and Third Logic Input 3330. First Logic Input 3210, Second Logic Input 3220 and Third Logic Input 3330 are configured to receive inputs from Switch 3110, Switch 3120, Switch 3130, or the like, respectively. The state of connected switches (Switch 3110, Switch 3120, etc.) is monitored by an optional Switch State Monitor 3340 and a Processing Logic 3350. Switch State Monitor 3340 is optionally a multiplexer, latch, logic circuit, or the like.

In some embodiments, Processing Logic 3350 is configured to process data received through a Data Input From Antenna 3360, to receive power from a Power Input From Antenna 3230, and to generate data for output through a

Data Output to Antenna 3370 responsive to the states of Switch 3110, Switch 3130, etc. The generated data is optionally further responsive to data stored in Memory 3150 and/or data received from Data Input from Antenna 3360.

The data received from Memory 3150 can include codes required for Processing Logic 3350 to generate specific data for communication through Data Output to Antenna 3370. For example, in some embodiments, Tag 2260 is configured to output an RF signal only if data in Memory 3150 matches a state of Switches 3110 and 3120. In some embodiments, the state of switches is used to determine which of several different alternative RF signals to transmit. For example, if Switch 3110 is activated then a first signal is transmitted, if Switch 3120 is activated then a second signal is transmitted, and if no switches are depressed then no signal is transmitted or a third signal is transmitted. The first and second signals are optionally associated with different financial accounts and/or different functions.

Some embodiments of the invention include a multi-switch credit card including one or more instances of Tag 2260. This multiswitch credit card optionally is configured to be associated with more than one financial account and switches may be used to indicate which of the more than one financial account should be used for a transaction. In one example, the multiswitch credit card includes an instance of Tag 2260 configured for engaging in a financial transaction responsive to Switch 3110 and also configured to operate an electronic lock responsive to Switch 3120.

Some embodiments of the invention optionally include programming of Tag 2260 to make associations with the one or more financial account. This programming can include entering data within Memory 3150. Alternatively, Tag 2260 is configured to include a plurality of exchangeable Memory 3150. In these embodiments, Tag 2260 is programmed to operate with different financial accounts and/or functions by inserting different instances of Memory 3150 within Switchable RFID Tag 2230. The multiswitch credit card is, thus, optionally a multi account credit card.

Some embodiments of Switchable RFID Device 2200 are configured to include a plurality of Tag 2260. Each member of the plurality of Tag 2260 may be responsive to one or more switches. In some embodiments, Switchable RFID Device 2200 is configured to receive one or more replaceable instances of Tag 2260. In these embodiments, Switchable RFID Device 2200 may be programmed by replacing an instance of Tag 2260. Multiple instances of Tag 2260 optionally share one instance of RFID Antenna 2240 and/or one instance of Memory 3150.

FIG. 34 illustrates a method according to various embodiments of the invention. In these embodiments, power is received by Tag 2260 through an RF or inductive signal in a Receive Power Step 3410. The RF signal optionally includes data received in a Receive Data Step 3420. The state of one or more of Switches 3110, Switch 3120, etc. is then determined in a Determine Switch State 3430 Step. This state is used to determine an RF response, of any, in a Determine Response Step 3440. The RF response is then sent in a Send Response Step 3450.

FIG. 35 illustrates various embodiments of the invention in which Switchable RFID Device 2200 is configured as a RF Powered Remote 3500 configured to control external devices. This RF Powered Remote 3500 optionally does not require an internal power source (e.g., is powered wirelessly). Power is received from an RF (radio frequency) signal via RFID Antenna 2240 and used to send a return signal, typically through the same instance of RFID Antenna 2240. RF Powered Remote 3500 uses one or more Switch-

able RFID Tag 2230 to activate and deactivate or modify the return signal. The one or more Switchable RFID Tag 2230 optionally share RFID Antenna 2240, power circuits, and/or processing logic. RF Powered Remote 3500 is typically a multifunction remote control.

RF Powered Remote 3500 is optionally used as part of a locking mechanism, such as in a vehicle lock or door lock. RF Powered Remote 3500 is optionally configured to control electronic equipment, such as a computing device, a video recording device, projector, a game, a stereo, or a television. RF Powered Remote 3500 is optionally configured to control a garage door opener.

As illustrated in FIG. 35, a Transmitter 3510 is configured to send an RF signal to provide power to RF Powered Remote 3500. This RF signal is received by RF Powered Remote 3500. When a switch (e.g. a First Switch 3520 or a Second Switch 3530), included in RF Powered Remote 3500, is in a first position the received power is used to send a return signal from RF Powered Remote 3500 to the device being controlled, e.g. a Controlled Device 3540. Transmitter 3510 is optionally included in Controlled Device 3540. When First Switch 3520 and/or Second Switch 3530 is in a second position the received power is not used to send the return signal from the remote, or is used to send a different return signal. The return signal may include audio, RF, infrared light, visible light, or the like. First Switch 3520 and Second Switch 3530 are optionally embodiments of Switch 3110, Switch 3120, or Switch 3130. In various embodiments, RF Powered Remote 3500 includes 1, 2, 3, 4 or more switches, such as First Switch 3520 and Second Switch 3530. Typically, different switches are configured to control different functions of Controlled Device 3540.

In some embodiments, First Switch 3520 and/or Second Switch 3530 are configured to control the collection of power from the RF signal. In some embodiments, First Switch 3520 and/or Second Switch 3530 are configured to prevent the power from flowing through an integrated circuit within the RF Powered Remote 3500. In some embodiments, the First Switch 3520 and/or Second Switch 3530 are configured to decouple an instance of RFID Antenna 2240 within RF Powered Remote 3500. In some embodiments, the First Switch 3520 and/or Second Switch 3530 are configured to prevent data transmission from RF Powered Remote 3500. In some embodiments, First Switch 3520 and/or Second Switch 3530 are configured to control logic within an instance of Tag 2260 within RF Powered Remote 3500. In various embodiments, First Switch 3520 and/or Second Switch 3530 are normally on or normally off. In some embodiments, more than one switch is configured to control logic within the same integrated circuit.

The embodiments of RF Powered Remote 3500 illustrated in FIG. 14 include a Power Collection Circuit 3550 configured to convert the received RF signal to electrical power of the operation of one or more Tag 2260. RF Powered Remote 3500 is configured to power an integrated circuit, e.g., Tag 2260, and send a return signal using the electrical power produced by Power Collection Circuit 3550. The RF Powered Remote optionally receives all of its electrical power from the Power Collection Circuit 3550.

Depending on the state of First Switch 3520 and/or Switch 3530, Tag 2260 may cause the return signal to be transmitted using a Return Signal Generator 3560. Return Signal Generator 3560 is optionally included in Tag 2260. Return Signal Generator 3560 is optionally shared by a plurality of Tag 2260 within RF Powered Remote 3500. In some embodiments, Return Signal Generator 3560 includes an instance of RFID Antenna 2240.

First Switch 3520 and Second Switch 3530 each control Tag 2260, such that the return signal is responsive to the states of these, and optionally further, switches. For example, in some embodiments, if First Switch 3520 is on, then Tag 2260 will include a first data in the return signal, and if Second Switch 3530 is on, then Tag 2260 will include a second (typically different) data in the return signal.

The RF Transmitter 3510 and Controlled Device 3540 are optionally separate. For example, the RF transmitter may be included in an automobile and the controlled device may be a garage door.

In some embodiments, First Switch 3520 is activated by insertion of RF Powered Remote 3500 in part of a locking system.

In some embodiments, First Switch 3520 is coupled to a button configured for turning the volume of an electronic device up and/or Second Switch 3530 is coupled to a different button configured for changing a channel.

In some embodiments, RF Powered Remote 3500 is configured to unlock a car.

In various embodiments, RF Powered Remote 3500 includes a wireless keypad, a wireless computer mouse, a wireless keyboard, a wireless microphone, a key, a telephone, an identity document, or the like.

In some embodiments, RF Powered Remote 3500 is included in a hermetically sealed and/or waterproof housing. Because the RF powered remote is remotely powered, there is no necessity for a battery compartment or power plug.

First Switch 3520 and Second Switch 3530 may include a push-button switch, a membrane switch, a sliding switch, a magnetic switch, or any of the many other switches known in the art to make and break electrical connections. First Switch 3520 is optionally part of a roller, wheel or dial that makes and breaks an electrical connection as it is turned. First Switch 3520 and Second Switch 3530 are optionally embodiments of Switch 2270.

In some embodiments, a single instance of RF Transmitter 3510 is configured to power a plurality of Tag 2260. Each of this plurality of Tag 2260 is optionally configured to control a separate electronic device or operate different functions in a single electronic device. The plurality Tags 2260 optionally included in the same RF Powered Remote 3500.

In some illustrative embodiments, an instance of RF Transmitter 3510 is disposed within a vehicle dashboard and a plurality of Tag 2260 are disposed within a steering wheel of the vehicle or rear view mirror. One of the plurality Tag 2260 is configured to control an audio system and another of the plurality of switchable RFID tags is configured to control a climate system (e.g., air conditioner or heating). In some embodiments, the wireless response signals generated by both of these Tag 2260 is received by a RF receiver and communicated to a circuit that then controls the separate electronic devices. In alternative embodiments, each of the separate electronic devices (e.g., audio system and climate system) includes a separate RF receiver configured to receive the response signals.

FIG. 36 illustrates an embodiment of Switchable RFID Device 2200 including a Multiswitch Credit Card 3600, according to various embodiments of the invention. Multiswitch Credit Card 3600 includes two or more switches, such as Switch 3610, Switch 3611, and optional Switch 3612. Switches 3610, 3611 and 3612 are optionally embodiments of Switch 3110 and Switch 3120. Multiswitch Credit Card 3600 further includes one or more instances of Tag 2260, an optional instance of Circuit 2250 configured to generate power for used by Tag 2260, and RFID Antenna

2240. In embodiments without Circuit **2250**, Multiswitch Credit Card **3600** includes its own power source (not shown).

Switches **3610-3612** are each configured to make or break an electrical connection, the state of which can be determined by the resistance of electric current flow or the presence of a current or voltage. In some embodiments, Switches **3610-3612** are membrane switches, such as Membrane Switch **2600**. In various embodiments, Multiswitch Credit Card **3600** including Switches **3610-3612** is less than 4, 3, 2, 1.5, 1, or 0.5 mm thick. In various embodiments, Switches **3610-3612** are essentially flush with a front surface of Multiswitch Credit Card **3600**.

In some embodiments, Circuit **2250** is configured to generate electrical power from the RF signal received via RFID Antenna **2240** for use by one or more instances of Tag **2260**. In some embodiments, Circuit **2250** and/or RFID Antenna **2240** are shared by several instances of Tag **2260** within Multiswitch Credit Card **3600**. In some embodiments, Multiswitch Credit Card **3600** is configured not to transmit an RF signal unless at least one of Switches **3610-3612** is activated. In some embodiments, Switches **3610-3612** are configured for entering an access code, such as PIN or password. The access code is optionally encoded by an order in which the states of switches are changed, by a switch combination, and/or by a temporal relationship between changes in switch state, e.g., a temporal pattern.

In some embodiments, Switches **3610-3612** are configured for approving the amount of a financial transaction. In some embodiments, Switches **3610-3612** are configured for selecting from among a plurality of financial accounts. For example, activating Switch **3610** may result in a transaction being debited from a checking account, activating Switch **3611** may result in a transaction being applied a first charge account, and activating Switch **3612** may result in a transaction being applied to a second charge account.

In some embodiments, Multiswitch Credit Card **3600** (or other embodiments of Switchable RFID Device **2200**) includes encryption logic configured to operate in response to the activation of switches. For example, the encryption logic may be configured to use data received via switches as an encryption or decryption key. The encryption logic may be configured to encrypt data received via switches prior to transmission of this data. In some embodiments, Switchable RFID Tag **2200** is configured to make use of rolling codes for security purposes. In these embodiments, synchronization of the codes is optionally be coordinated by a central server configured to communicate with point of sale stations. In some embodiments, a switch is activated using a biometric sensor. The features described herein with respect to various embodiments of Switchable RFID Device **2200**, such as Multiswitch Credit Card **3600**, may be included in other types of identity devices.

In various embodiments of the invention, an identity device includes both one or more electrical contact configured to make physical electrical contact with a reader and a RFID tag configured to communicate wirelessly with a reader. The physical contact is optionally used to convey communication that is different from the wireless communication. For example, the physical connection based communication may include programming of a circuit within the RFID tag (e.g., programming account number), while the wireless communication may be more limited than the physical connection based programming, (e.g., the wireless communication may be limited to reading the programmed account number). In another example, the wireless communication may be configured for a limited set of transaction

types (e.g., those less than \$50, or deposits), while the physical communication is configured for additional transaction types (e.g., larger value withdrawals). Further, the physical communication may be used for downloading transaction logs or other data stored on the ID card. Transaction logs are optionally stored using power received through RFID Antenna **2240**.

In various embodiments, an identity device includes a plurality of switches and is configured to engage in a transaction or allow access (to an account, data, or a physical location) responsive to whether proper members of the plurality of switches are pressed. For example, in one embodiment the ID card includes 10 switches configured for a user to enter a PIN (personal identification number) or password. Only when the proper data is entered using the plurality of switches will the ID card participate in certain functions, such as an electronic payment or opening of a lock. As described further herein, different numbers of switches are possible.

In various embodiments, an identity device includes logic configured to process data entered using a plurality of switches. This logic may, for example, prevent the identity device from transmitting an RF signal unless the entered data matches previously stored data, for example, if an entered PIN matches a stored access code. The logic may be responsive to the order of switches activated, combinations of switch activation (e.g., which switches are activated at the same time), or which of the plurality of switches are activated. Timing may be achieved through the use of appropriate RC (resister-capacitor) circuits or a clock signal.

Various embodiments of the invention include a modified version of Basic Access Control. In these embodiments, the logic is configured to prevent the identity device from transmitting certain data unless the data entered using switches on the identity device matches an ID number of a RFID reader making a request. The logic may be configured to implement Basic Access Control, such as that used in electronic U.S. passports, but unlike the system used in current passports, the data entered is an ID of the reader and the data is entered at the passport (or other identity device) rather than at the reader.

In various embodiments, the identity device includes a plurality of switches configured for a user to enter data associated with a reader. For example, in some embodiments, the switches are configured to receive an ID number of a point of sale (POS) device. Logic within the identity device may then use this ID number to assure that a transaction is communicated to the correct POS device. For example, if several vending devices are positioned adjacent to each other, the ID number of one of the vending devices may be entered in the identity device using the plurality of switches and the ID card may then be enabled to engage in a transaction with that particular vending device but not the other nearby vending devices.

Passwords, PINs, or the like received by the identity device through the plurality of switches are optionally stored in volatile memory within the identity device. When the identity device ceases to receive energy through an RF signal the data stored in this volatile memory is discarded (lost). In some embodiments, this data is stored in non-volatile memory and thus retained between RF transmissions.

In some embodiments, the identity device is configured to store an account balance in static memory. Logic within the identity device is optionally configured such that the account balance can only be increased using a physical connection, while the account balance can be debited using a wireless

connection. Alternatively, logic within the identity device is optionally configured such that the account balance can only be debited using a physical connection.

Some embodiments of the invention include methods of purchasing using a switchable RFID. The identity device is placed within the reading range of a wireless POS device. One of a plurality of switches within identity device is activated such that an RFID tag will respond to an RF signal from the POS device. The RFID tag responds to the RF signal from the POS by energizing itself using the RF signal and generating a response RF signal. The responsive RF signal includes an account number such as a checking or savings account number, a credit card number, identity number, or the like, responsive to the switch.

FIGS. 37A-37C illustrate positions of RFID Antenna 2240 within Multiswitch Credit Card 3600, according to various embodiments of the invention. As illustrated in FIG. 37A, in some embodiments, RFID Antenna 2240 is disposed such that Embossed Lettering or Numbering 3620 is inside of RFID Antenna 2240. In these embodiments, at least part of Switch 2270 (or a plurality thereof) is optionally disposed inside of RFID Antenna 2240. As illustrated in FIGS. 37B and 37C, in some embodiments, RFID Antenna 2240 is disposed primarily in the part of a credit card (e.g., the upper half) that does not include Embossed Lettering or Numbering 3620. In these embodiments, Switch 2270 (or a plurality thereof) may be disposed either inside and/or outside of RFID Antenna 2240. As illustrated in FIG. 37C, when Switch 2270 is disposed outside of RFID Antenna, Connections 3615 between Switch 2270 and Tag 2260 are optionally routed to avoid Embossed Lettering or Numbering 3620. In some embodiments, Spacer 2640 is comprised of a material that can be embossed to form raised lettering and numbering (e.g., a name and credit card number). In these embodiments, the manufacture of Embossed Lettering or Numbering 3620 can be made through Spacer 2640.

In some embodiments, of the invention, one or more instances of Switch 2270 are configured to control whether Tag 2260 (and/or associated memory) are in a programmable state or a non-programmable state. For example, when an instance of Switch 2270 is in a first state writing to non-volatile memory within Tag 2260 is allowed and when Switch 2270 is in a second state writing to the non-volatile memory is not allowed but reading of the non-volatile memory may be allowed. In some embodiments, Switch 2270 is initially in a state wherein the non-volatile memory can be written to and the switch is then irreversible changed to a state wherein the non-volatile memory can no longer be written to.

The irreversible change optionally includes breaking of a conductor. For example, in some embodiments, an RFID enabled identity device is configured such that an instance of Switch 2270 comprises a Conductor 3810 coupled to Tag 2260. As illustrated in FIG. 38, when Conductor 3810 is unbroken Tag 2260 is in a programmable state, e.g., non-volatile memory within Switchable RFID Tag 2230 can be written to. After programming this conductor is broken and Tag 2260 is thus irreversibly changed to a nonprogrammable state. Data already programmed within Switchable RFID Tag 2230 may be locked by the breaking of Conductor 3850. In one embodiment, Conductor 3810 is broken through the manufacture of Embossed Lettering or Numbering 3620. For example, embossing a credit card number into a credit card can break a conductor and thus lock the contents of non-volatile memory within the credit card. In alternative embodiments, an identity device includes a plurality of Conductor 3810 and members of this plurality are broken in

order to program function of Tag 2260. Each member of the plurality of Conductor 3810 that is or is not broken represents one bit of logic programmed.

Some embodiments of the invention include a switchable RFID tag is configured to be remotely switched using an RF signal. In some embodiments, in an OFF state, the RFID tag will not transmit a response signal and thus is not remotely detectable using an RF signal. In an ON state, the RFID tag will transmit a response signal. The RFID tag is switched between the ON state and the OFF state through receipt of a specific command or commands, through an RF signal. In alternative embodiments, the RFID tag includes multiple ON states, optionally in combination with an OFF state.

FIG. 39 illustrates a remotely switchable RFID Tag 3900 including an Antenna 3910, a Power Electronics 3920, and an Integrated Circuit 3930. RFID Tag 3900 is optionally an embodiment of other RFID tags disclosed herein. Likewise, Antenna 3910, Power Electronics 3920 and Integrated Circuit 3930 are optionally embodiments of other antennae, power electronics and integrated circuits disclosed herein. Antenna 3910 is configured to send and receive data encoded in an RF signal and also optionally configured to receive sufficient energy to power RFID Tag 3900.

Power Electronics 3920 are configured to receive energy through Antenna 3910 and to power Integrated Circuit 3930 using this received energy. Power Electronics 3920 typically include elements such as a diode, capacitor, transistor, or the like.

Integrated Circuit 3930 includes an Input 3935 configured to receive data from Antenna 3910 and power from Power Electronics 3920. Integrated Circuit 3930 further includes an Output 3940 configured to convey data to Antenna 3910 for transmission as an RF signal.

Integrated Circuit 3930 further includes an optional State Memory 3945 configured to store the current state of the RFID Tag, e.g., ON or OFF. In various embodiments, State Memory 3945 includes a memory location in a static random access memory, a magnetic memory, or the like. In these embodiments, the state stored within State Memory 3945 is preserved without a constant source of power. In some embodiments, State Memory 3945 includes memory configured to store data only while power is available. In this embodiment, the ON state is typically temporary and automatically reverts to the OFF state after power is no longer available.

Integrated Circuit 3930 further includes an optional Data Memory 3950 configured to store data received through Antenna 3910, and/or to be transmitted using Antenna 3910. The data stored in Data Memory 3950 may include a serial number of RFID Tag 3900, identification data, biometric data, medical information, license information, or the like.

Integrated Circuit 3930 further includes a Key Memory 3955 configured to store a key required to change the state of the RFID Tag 3900 from ON to OFF, from OFF to ON, and/or between two ON states. Key Memory 3955 is typically static memory, and optionally read only memory or write-once memory. In other embodiments, the Key Memory 3955 is memory configured for temporary storage of data.

Integrated Circuit 3930 further includes Switch Logic 3960 configured to read the state stored in State Memory 3945 and, responsive to the read state, either transmit or not transmit an RF signal using Antenna 3910. The transmitted data optionally includes data stored in Data Memory 3950. In some embodiments, Switch Logic 3960 is configured to not transmit an RF signal unless the state read from State Memory 3945 indicates that the RFID Tag is in an ON state.

In some embodiments, Switch Logic 3960 is configured to read the state stored in State Memory 3945 and, responsive to the read state, transmit one of a plurality of alternative data stored in Data Memory 3950. In some embodiments, Switch Logic 3960 is configured to read the state stored in State Memory 3945 and, responsive to the read state, transmit different amounts of data stored in Data Memory 3950.

In some embodiments, Switch Logic 3960 is configured to receive data through Antenna 3910, to read a key from Key Memory 3955, to compare the received data with the read key, and to change the state stored in State Memory 3945 responsive to this comparison. For example, in some embodiments, if the read key matches the received data, the state of the RFID Tag 3900 is set to ON, or changed from one ON state to another ON state. In some embodiments, Switch Logic 3960 includes logic configured to decrypt or apply a hash function to the received data prior to the comparison. The Switch Logic 3960 can include software, hardware, and/or firmware. In some embodiments, State Memory 3945 is configured to store a rolling code.

In some embodiments, Integrated Circuit 3930 is embodied in several devices. For example, the functionality of Integrated Circuit 3930 may be distributed among several chips. In some embodiments, Key Memory 3955, Antenna 3910, Switch Logic 3960 and/or State Memory 3945 are configured to be shared by more than one instance of Integrated Circuit 3930. For example, two or more instances of RFID Tag 3900 may be included in a single device and these two or more instances of RFID Tag 3900 may share a single instance of Key Memory 3955, Antenna 3910, Switch Logic 3960 and/or State Memory 3945.

In some embodiments, RFID Tag 3900 further includes a mechanical switch configured to control operation of RFID Tag 3900. This switch may include, for example, Switch 2270 (FIG. 22). For example, in one embodiment, Switch Logic 3960 is configured for turning ON and OFF operation of RFID Tag 3900, while Switch 2270 is configured to select between alternative ON states. In an alternative embodiment, Switch 2270 is configured for turning ON and OFF operation of RFID Tag 3900 and Switch Logic 3960 is configured for selecting between alternative ON states. In some embodiments, proper activation of both Switch 2270 and Switch Logic 3960 is required to turn RFID Tag 3900 to an ON state. Thus, in order for RFID Tag 3900 to transmit certain information, or to transmit at all, Switch 2270 must be activated by a person and Switch Logic 3960 must receive a proper key from an RF reader. This provides a dual layer of mechanical and key based security. In some embodiments, the switch must be activated and a proper key must be received in order for RFID Tag 3900 to transmit certain information. In some embodiments, use of Switch 2270 will activate RFID Tag 3900 in a first ON state and use of Switch Logic 3960 (through an RF signal) will activate RFID Tag 3900 in a second ON state. The second ON state optionally requires use of both Switch 2270 and Switch Logic 3960.

In some embodiments, Integrated Circuit 3930 also includes an independent Power Supply 3965 such as a battery or capattery.

In some embodiments, the switchable RFID Tag 3900 of FIG. 1 is included in an identification document such as a driver's license, green card, passport, or the like. In some embodiments, the Switchable RFID Tag 3900 is included in a wireless key configured to open a lock, to access data, to gain entry, or the like. In some embodiments, Switchable

RFID Tag 3900 is included in a cellular telephone or another device configured to communicate using WiFi, WiMAX, or similar non-RFID standards.

FIG. 40 is a flowchart illustrating a method of changing a state of RFID Tag 3900. In an optional Receive Energy Step 4010, energy sufficient to power RFID Tag 3900 is received by Antenna 3910. Receive Energy Step 4010 is typically similar to Receive Power Step 3410. In a Receive Data Step 4020, data is received by Antenna 3910 in the form of an RF signal. In some embodiments, Receive Data Step 4020 requires that a mechanical switch be activated. In a Read Key Step 4030, a key is read from Key Memory 3955. Optionally, the data received in the Receive Data Step 4020 is decrypted or otherwise processed. In a Compare Step 4040, the read key is compared with the, optionally processed, data received in the Receive Data Step 4020.

In a Change State Step 4050, the state of RFID Tag 3900 is changed responsive to results of the comparison made in the Compare Step 4040. In some embodiments, if there is a match between the key and the data then the state of RFID Tag 3900 is set to ON. Setting the state ON optionally includes writing a value to State Memory 3945. In some embodiments, if there is no match between the key and the data then the state is set to OFF. In some embodiments, if there is a match between the key and the data, then the state is set to one of two or more possible ON states. In one of the two or more possible ON states, RFID Tag 3900 can transmit a response RF signal but the data that can be included in the response RF signal is restricted relative to another of the two or more possible ON states. For example, in one embodiment, in one ON state RFID tag 3900 is configured to include a name in the response RF signal, but another ON state RFID tag 3900 is configured to include the name and medical information in the response RF signal.

In some embodiments, RFID Tag 3900 is automatically returned to the OFF state from the ON state, in a Revert Step 4060. For example, in one embodiment the ON state remains only so long as there is charge on a capacitor. When this charge dissipates or is used, the RFID automatically returns to a default OFF state. The automatic switch back to the OFF state can be dependent on when power is no longer received from an RF signal, on the timing characteristics of an RC (resistor-capacitor) circuit, on Switch 2270, on an RF signal received, and/or the like.

FIG. 41 is a flowchart illustrating a method of operating the RFID Tag 3900 illustrated in FIG. 39. In an optional Receive Energy Step 4010 energy sufficient to power the RFID is received by Antenna 3910. In a Read State Step 4120 the state of the RFID Tag is read from State Memory 2245. In a State? Step 4130 the read state is examined. If the read state is ON, then in a Send Response Step 4140 an RF response is sent from the RFID Tag 3900 using Antenna 3910. If the read state is OFF, then the RFID Tag 3900 is prevented from sending an RF response, in an Abort Response Step 4150. In some embodiments, that include more than two states, the read state can be something other than ON or OFF. If the read state is a state other than ON or OFF then a restricted RF response is sent in a Send Restricted Response Step 4160. The restricted response typically includes less or different data than would be included if the read state had been ON.

The steps shown in FIGS. 40 and 41 are optionally performed using Integrated Circuit 3930 of FIG. 39.

In some embodiments, first data in a transmission is configured to change the state of an RFID tag to ON. Further data in the transmission is then configured to elicit a responding transmission from the RFID tag. After the trans-

mission is concluded the RFID tag automatically reverts to the OFF state. These embodiments optionally include non-volatile memory for storage of the state.

In some embodiments, data in a transmission is configured to change the state of an RFID tag to ON. The ON state persists until the RFID tag receives data configured to change the state of the RFID tag to OFF.

Several embodiments are specifically illustrated and/or described herein. However, it will be appreciated that modifications and variations are covered by the above teachings and within the scope of the appended claims without departing from the spirit and intended scope thereof. For example, an RFID key device may include more than one RFID tag and moving of shielding may be used to determine which RFID tag can communicate with readers. The RFID tags discussed herein may include active or passive contactless circuits configured to transmit identification information. For example, in some embodiments, Tag 2260 is an active rather than a passive RFID tag. Examples discussed herein in relation to credit cards can equally be applied to other types of financial card such as a debit card, or prepaid card. For example, in some embodiments, RFID Tag 3900 is configured to change the ON/OFF state in response to a signal from a point of sale system indicating that an item has been sold. In these embodiments, RFID Tag 3900 is optionally configured to send different signals before and after a sale. A first of the different signals may be used to determine that the item has not yet been sold, and a second of the different signals may be used to determine that the item has been sold and/or may be returned. The features illustrated in FIGS. 39-41 are optionally included in embodiments illustrated by other figures of this application.

The embodiments discussed herein are illustrative of the present invention. As these embodiments of the present invention are described with reference to illustrations, various modifications or adaptations of the methods and or specific structures described may become apparent to those skilled in the art. All such modifications, adaptations, or variations that rely upon the teachings of the present invention, and through which these teachings have advanced the art, are considered to be within the spirit and scope of the present invention. Hence, these descriptions and drawings should not be considered in a limiting sense, as it is understood that the present invention is in no way limited to only the embodiments illustrated.

What is claimed is:

1. A method of reading a passport, the method comprising:

moving a radio frequency shielding away from an RFID tag by opening a cover of the passport, opening of the cover resulting in movement of a first part of the cover away from a second part of the cover, the first part including the RFID tag and the second part including the radio frequency shielding, the radio frequency including metallic fibers configured to shield the RFID tag when the cover is closed and to allow reading of the RFID tag when the cover is open; and reading identifying information from the RFID tag, the RFID tag being powered by power received through an RFID antenna.

2. The method of claim 1, further comprising activating a switch in order to turn on readability of the identifying information from the RFID tag.

3. The method of claim 2, wherein the switch is electronic.

4. The method of claim 2, wherein the switch is activated using a radio frequency signal.

5. The method of claim 2, wherein the switch is activated using a wireless signal.

6. The method of claim 2, wherein the readability of the identifying information from the RFID tag is normally off.

7. The method of claim 2, wherein the switch is activated in responsive to data received via an antenna of the RFID tag.

8. The method of claim 2, further comprising retrieving a key from a key memory within the passport, wherein the switch is responsive to a comparison between data received via the antenna and the key data retrieved from the key memory.

9. The method of claim 1, wherein the metallic fibers are disposed in a mesh.

10. The method of claim 1, wherein the metallic fibers are laminated within the cover.

11. The method of claim 1, wherein the RFID tag is disposed at least 5 mm from a fold separating the first part of the cover from the second part of the cover.

12. The method of claim 1, wherein the radio frequency shielding comprises multiple shielding layers.

13. The method of claim 1, wherein reading the identifying information from the RFID tag is attempted from at least two different directions.

14. The method of claim 1, further comprising switching the RFID tag from a first ON state to a second ON state, the identifying information being readable from the RFID tag in the second ON state but not in the first ON state.

15. The method of claim 14, wherein the RFID tag is detectable in both the first ON state and the second ON state.

16. The method of claim 14, wherein the first ON state and the second ON state are stored in a state memory of the RFID tag.

17. The method of claim 1, wherein the identifying information includes a photograph.

18. The method of claim 1, wherein reading the identifying information from the RFID tag is performed using two or more RFID readers.

19. The method of claim 1, wherein the identifying information is encrypted.

20. The method of claim 1, further comprising switching the RFID tag from a first state to a second state, the identifying information being readable from the RFID tag in the second state but not in the first state.

21. The method of claim 20, wherein the RFID tag is detectable using a wireless signal in both the first state and the second state.

22. The method of claim 20, wherein the RFID tag is detectable using a wireless signal in the second state and is not detectable using the wireless signal in the first state.

23. The method of claim 1, further comprising: receiving first data through the RF antenna; reading a key from key memory; using an integrated circuit to compare the first data received through the RF antenna with the key read from the key memory, the integrated circuit powered by power received through the RFID antenna; changing a state of the RFID tag from a first state to a second state responsive to the comparison; and providing an RF response, a content of data in the RF response being responsive to the state of the RFID tag.

24. The method of claim 23, wherein the first state and the second state are alternative ON states.

25. The method of claim 1, wherein reading the identifying information from the RFID tag is performed from at least two different directions.